

AC Servomotors/Servo Drives

1S-series with Built-in EtherCAT® Communications

Incremental Encoder Type User's Manual

R88M-1L□/-1M□ (AC Servomotors)

R88D-1SN□-ECT (AC Servo Drives)



NOTE

All rights reserved. No part of this publication may be reproduced, stored in a retrieval system, or transmitted, in any form, or by any means, mechanical, electronic, photocopying, recording, or otherwise, without the prior written permission of OMRON.

No patent liability is assumed with respect to the use of the information contained herein. Moreover, because OMRON is constantly striving to improve its high-quality products, the information contained in this manual is subject to change without notice. Every precaution has been taken in the preparation of this manual. Nevertheless, OMRON assumes no responsibility for errors or omissions. Neither is any liability assumed for damages resulting from the use of the information contained in this publication.

Trademarks

- Sysmac and SYSMAC are trademarks or registered trademarks of OMRON Corporation in Japan and other countries for OMRON factory automation products.
- EtherCAT® is registered trademark and patented technology, licensed by Beckhoff Automation GmbH, Germany.
- Safety over EtherCAT® is registered trademark and patented technology, licensed by Beckhoff Automation GmbH, Germany.
- ODVA, CIP, CompoNet, DeviceNet, and EtherNet/IP are trademarks of ODVA.

Other company names and product names in this document are the trademarks or registered trademarks of their respective companies.

Introduction

Thank you for purchasing a 1S-series Servo Drive. This User's Manual describes the installation and wiring methods of the 1S-series Incremental Encoder Type Servomotors and parameter setting method which is required for the operation, as well as troubleshooting and inspection methods. For the contents that are not described in this manual, refer to the *AC Servomotors/Servo Drives 1S-series with Built-in EtherCAT® Communications User's Manual (I586)*.

Intended Audience

This User's Manual is intended for the following personnel, who must also have electrical knowledge (certified electricians or individuals who have equivalent knowledge).

- Personnel in charge of introducing the FA equipment
- Personnel in charge of designing the FA systems
- Personnel in charge of installing and connecting the FA equipment
- Personnel in charge of managing the FA systems and facilities

Notice

This User's Manual contains information you need to know to correctly use the 1S-series Servo Drives and peripheral equipment.

Before using the Servo Drive, read this User's Manual and gain a full understanding of the information provided herein.

After you finished reading this User's Manual, keep it in a convenient place so that it can be referenced at any time.

Make sure this User's Manual is delivered to the end user.

Manual Structure

This section explains the page structure and symbol icons.

Page Structure

The following page structure is used in this manual.

Level 1 heading →

Level 2 heading →

Level 3 heading →

7 Applied Functions

7-9 Soft Start Function

This function sets the acceleration and deceleration against the velocity command input inside the Servo Drive and uses these values for speed control.

With this function, soft starts are possible when the step rotation velocity commands are input. To reduce any impacts made by acceleration changes, you can also use the velocity command filter (first-order lag).

7-9-1 Objects Requiring Settings

Index (hex)	Subindex (hex)	Name	Description	Reference
3021	-	Velocity Command Filter	-	P. 9-19
	01	Acceleration Time	Sets the acceleration time during acceleration.	P. 9-19
	02	Deceleration Time	Sets the deceleration time during deceleration.	P. 9-19
	03	IIR Filter Enable	Selects whether to enable or disable the IIR filter in the velocity command filter. 0: Disabled 1: Enabled	P. 9-20
	04	Filter Cutoff Frequency	Sets the cutoff frequency for the IIR filter.	P. 9-20

7-9-2 Soft Start Acceleration/Deceleration Time

For a step velocity command input, set the time until the velocity command reaches 1,000 r/min in Acceleration Time.

Similarly, set the time until the velocity command slows from 1,000 r/min down to 0 r/min in Deceleration Time.

Acceleration Time (ms) = $Vc/1,000 \text{ r/min} \times \text{Acceleration Time} \times 0.1 \text{ ms}$
 Deceleration Time (ms) = $Vc/1,000 \text{ r/min} \times \text{Deceleration Time} \times 0.1 \text{ ms}$

7 - 30
1S-series AC Servomotors and Servo Drives User's Manual (with Built-in EtherCAT Communications)

← Manual name

Note The above page is only a sample for illustrative purposes. It is not the actual content of this User's Manual.

7 Applied Functions

Precautions for Correct Use

 Do not set the Acceleration Time and the Deceleration Time when the position loop structure with a host controller is used.

7-9-3 Velocity Command Filter (First-order Lag)
 The velocity command filter (first-order lag) is an IIR filter used for speed commands.

1S-series AC Servomotors and Servo Drives User's Manual (with Built-in EtherCAT Communications) 7 - 31

Special information
Icons indicate precautions, additional information, or reference information.

Level 2 heading
Gives the current heading.

Page tab
Gives the number of the main section.

Level 3 heading
Gives the current heading.

Note This illustration is provided only as a sample. It may not literally appear in this manual.

Special Information

Special information in this manual is classified as follows:



Precautions for Safe Use

Precautions on what to do and what not to do to ensure safe usage of the product.



Precautions for Correct Use

Precautions on what to do and what not to do to ensure proper operation and performance.



Additional Information

Additional information to read as required.

This information is provided to increase understanding or make operation easier.



Version Information

Information on differences in specifications and functionality for Servo Drives with different unit versions and for different versions of the Sysmac Studio is given.

Manual Configuration

This User's Manual consists of the following sections.

Read the necessary section or sections by reference to the following table.

Section		Outline
Section 1	Features and System Configuration	This section explains the features of the Servo Drive and name of each part.
Section 2	Models and External Dimensions	This section explains the models of Servomotors and peripheral devices, and provides the external dimensions and mounting dimensions.
Section 3	Specifications	This section provides the general specifications, characteristics, encoder specifications of the Servomotors and other peripheral devices.
Section 4	Configuration and Wiring	This section explains the conditions for installing Servomotors, the wiring methods including wiring conforming to EMC Directives.
Section 5	Details on Servo Parameters	This section explains the details related to the Servomotors, including the set values, settings, and the display.
Section 6	Operation	This section provides the operational procedure and explains how to operate in each mode.
Section 7	Troubleshooting	This section explains the items to check when problems occur, and troubleshooting by the use of error displays or operation state.
Section 8	Maintenance and Inspection	This section explains maintenance and inspection of the Servomotors and Servo Drives.
Appendices		The appendices provide explanation for the profile that is used to control the Servo Drive, lists of objects, and Sysmac error status codes.

Sections in this Manual

1	Features and System Configuration	I	Index	1	I
2	Models and External Dimensions			2	
3	Specifications			3	
4	Configuration and Wiring			4	
5	Details on Servo Parameters			5	
6	Operation			6	
7	Troubleshooting			7	
8	Maintenance and Inspection			8	
A	Appendices			A	

CONTENTS

Introduction	1
Manual Structure	2
Manual Configuration	4
Sections in this Manual	5
Terms and Conditions Agreement	10
Safety Precautions	12
Items to Check After Unpacking	23
Related Manuals	26
Terminology	28
Revision History	30

Section 1 Features and System Configuration

1-1 Outline	1-2
1-1-1 Features of 1S-series Servo Drives	1-2
1-1-2 EtherCAT	1-3
1-1-3 Object Dictionary	1-4
1-2 System Configuration	1-5
1-3 Names and Functions	1-6
1-3-1 Servomotor Part Names	1-6
1-3-2 Servomotor Functions	1-7
1-4 Applicable Standards	1-8
1-4-1 EU Directives	1-8
1-4-2 UL and CSA Standards	1-9
1-4-3 Korean Radio Regulations (KC)	1-9
1-4-4 SEMI F47	1-10
1-4-5 Australian EMC Labeling Requirements (RCM)	1-10
1-5 Unit Versions	1-11
1-5-1 Confirmation Method	1-11
1-5-2 Unit Versions and Sysmac Studio Versions	1-11

Section 2 Models and External Dimensions

2-1 Servo System Configuration	2-2
2-2 How to Read Model Numbers	2-4
2-2-1 Servomotor	2-4
2-3 Model Tables	2-5
2-3-1 Servomotor Model Tables	2-5
2-3-2 Servo Drive and Servomotor Combination Tables	2-6
2-3-3 Servomotor and Decelerator Combination Tables	2-7
2-3-4 Cable and Connector Model Tables	2-7
2-4 External and Mounting Dimensions	2-12

2-4-1	Servomotor Dimensions	2-12
-------	-----------------------------	------

Section 3 Specifications

3-1	Servo Drive Specifications	3-2
3-1-1	Characteristics.....	3-2
3-1-2	Main Circuit and Motor Connections	3-4
3-1-3	Encoder Connector (CN2) Specifications	3-8
3-1-4	Overload Characteristics (Electronic Thermal Function).....	3-8
3-2	Servomotor Specifications	3-10
3-2-1	General Specifications.....	3-10
3-2-2	Encoder Specifications	3-11
3-2-3	Characteristics.....	3-12
3-3	Cable and Connector Specifications	3-17
3-3-1	Encoder Cable Specifications.....	3-17
3-3-2	Motor Power Cable Specifications.....	3-22
3-3-3	Resistance to Bending of Flexible Cable	3-34
3-3-4	Connector Specifications	3-36

Section 4 Configuration and Wiring

4-1	Installation Conditions	4-2
4-1-1	Servomotor Installation Conditions.....	4-2
4-2	Wiring	4-5
4-2-1	Connector Attachment Procedure	4-5
4-2-2	Power/Brake Connector Attachment Procedure.....	4-7
4-3	Wiring Conforming to EMC Directives	4-8
4-3-1	Peripheral Equipment Connection Examples	4-9
4-3-2	Selecting Connection Component.....	4-18

Section 5 Details on Servo Parameters

5-1	Object Description Format	5-2
5-2	External Device-related Objects.....	5-4
5-3	Encoder-related Objects	5-6

Section 6 Operation

6-1	Operational Procedure.....	6-2
6-2	Preparing for Operation	6-3
6-2-1	Items to Check Before Turning ON the Power Supply	6-3
6-2-2	Turning ON the Power Supply	6-4
6-2-3	Checking the Displays.....	6-5
6-3	Test Run	6-7
6-3-1	Preparations for Test Run.....	6-7
6-3-2	Test Run via USB Communications from the Sysmac Studio	6-8

Section 7 Troubleshooting

7-1	Actions for Problems	7-2
7-1-1	Preliminary Checks When a Problem Occurs	7-2
7-1-2	Precautions When a Problem Occurs	7-3

7-1-3	Replacing the Servomotor or Servo Drive	7-4
7-2	Warnings	7-6
7-2-1	Related Objects	7-6
7-2-2	Warning List.....	7-8
7-3	Errors.....	7-10
7-3-1	Error List	7-10
7-3-2	Deceleration Stop Operation at Errors.....	7-12
7-4	Information.....	7-13
7-4-1	Related Objects	7-13
7-4-2	Information List	7-13
7-5	Troubleshooting	7-14
7-5-1	Troubleshooting Using Error Displays	7-14
7-5-2	Troubleshooting Using AL Status Codes	7-35
7-5-3	Troubleshooting Using the Operation State	7-39

Section 8 Maintenance and Inspection

8-1	Periodic Maintenance.....	8-2
8-2	Servo Drive Lifetime.....	8-3
8-3	Servomotor Lifetime.....	8-4

Appendices

A-1	Sysmac Error Status Codes	A-2
A-1-1	Error List	A-2
A-1-2	Error Descriptions	A-14

Index

Terms and Conditions Agreement

Warranty, Limitations of Liability

Warranties

● Exclusive Warranty

Omron's exclusive warranty is that the Products will be free from defects in materials and workmanship for a period of twelve months from the date of sale by Omron (or such other period expressed in writing by Omron). Omron disclaims all other warranties, express or implied.

● Limitations

OMRON MAKES NO WARRANTY OR REPRESENTATION, EXPRESS OR IMPLIED, ABOUT NON-INFRINGEMENT, MERCHANTABILITY OR FITNESS FOR A PARTICULAR PURPOSE OF THE PRODUCTS. BUYER ACKNOWLEDGES THAT IT ALONE HAS DETERMINED THAT THE PRODUCTS WILL SUITABLY MEET THE REQUIREMENTS OF THEIR INTENDED USE.

Omron further disclaims all warranties and responsibility of any type for claims or expenses based on infringement by the Products or otherwise of any intellectual property right.

● Buyer Remedy

Omron's sole obligation hereunder shall be, at Omron's election, to (i) replace (in the form originally shipped with Buyer responsible for labor charges for removal or replacement thereof) the non-complying Product, (ii) repair the non-complying Product, or (iii) repay or credit Buyer an amount equal to the purchase price of the non-complying Product; provided that in no event shall Omron be responsible for warranty, repair, indemnity or any other claims or expenses regarding the Products unless Omron's analysis confirms that the Products were properly handled, stored, installed and maintained and not subject to contamination, abuse, misuse or inappropriate modification. Return of any Products by Buyer must be approved in writing by Omron before shipment. Omron Companies shall not be liable for the suitability or unsuitability or the results from the use of Products in combination with any electrical or electronic components, circuits, system assemblies or any other materials or substances or environments. Any advice, recommendations or information given orally or in writing, are not to be construed as an amendment or addition to the above warranty.

See <http://www.omron.com/global/> or contact your Omron representative for published information.

Limitation on Liability; Etc

OMRON COMPANIES SHALL NOT BE LIABLE FOR SPECIAL, INDIRECT, INCIDENTAL, OR CONSEQUENTIAL DAMAGES, LOSS OF PROFITS OR PRODUCTION OR COMMERCIAL LOSS IN ANY WAY CONNECTED WITH THE PRODUCTS, WHETHER SUCH CLAIM IS BASED IN CONTRACT, WARRANTY, NEGLIGENCE OR STRICT LIABILITY.

Further, in no event shall liability of Omron Companies exceed the individual price of the Product on which liability is asserted.

Application Considerations

Suitability of Use

Omron Companies shall not be responsible for conformity with any standards, codes or regulations which apply to the combination of the Product in the Buyer's application or use of the Product. At Buyer's request, Omron will provide applicable third party certification documents identifying ratings and limitations of use which apply to the Product. This information by itself is not sufficient for a complete determination of the suitability of the Product in combination with the end product, machine, system, or other application or use. Buyer shall be solely responsible for determining appropriateness of the particular Product with respect to Buyer's application, product or system. Buyer shall take application responsibility in all cases.

NEVER USE THE PRODUCT FOR AN APPLICATION INVOLVING SERIOUS RISK TO LIFE OR PROPERTY WITHOUT ENSURING THAT THE SYSTEM AS A WHOLE HAS BEEN DESIGNED TO ADDRESS THE RISKS, AND THAT THE OMRON PRODUCT(S) IS PROPERLY RATED AND INSTALLED FOR THE INTENDED USE WITHIN THE OVERALL EQUIPMENT OR SYSTEM.

Programmable Products

Omron Companies shall not be responsible for the user's programming of a programmable Product, or any consequence thereof.

Disclaimers

Performance Data

Data presented in Omron Company websites, catalogs and other materials is provided as a guide for the user in determining suitability and does not constitute a warranty. It may represent the result of Omron's test conditions, and the user must correlate it to actual application requirements. Actual performance is subject to the Omron's Warranty and Limitations of Liability.

Change in Specifications

Product specifications and accessories may be changed at any time based on improvements and other reasons. It is our practice to change part numbers when published ratings or features are changed, or when significant construction changes are made. However, some specifications of the Product may be changed without any notice. When in doubt, special part numbers may be assigned to fix or establish key specifications for your application. Please consult with your Omron's representative at any time to confirm actual specifications of purchased Product.

Errors and Omissions



Information presented by Omron Companies has been checked and is believed to be accurate; however, no responsibility is assumed for clerical, typographical or proofreading errors or omissions.

Safety Precautions

- To ensure that the 1S-series Servomotor/Servo Drive as well as peripheral equipment are used safely and correctly, be sure to read this *Safety Precautions* section and the main text before using the product. Learn all items you should know before use, regarding the equipment as well as the required safety information and precautions.
- Make an arrangement so that this User's Manual also gets to the end user of this product.
- After reading this User's Manual, keep it in a convenient place so that it can be referenced at any time.

Explanation of Displays





- The precautions indicated here provide important information for safety. Be sure to heed the information provided with the precautions.
- The following signal words are used to indicate and classify precautions in this User's Manual.

 DANGER	Indicates an imminently hazardous situation which, if not avoided, is likely to result in serious injury or may result in death. Additionally there may be severe property damage.
 WARNING	Indicates a potentially hazardous situation which, if not avoided, will result in minor or moderate injury, or may result in serious injury or death. Additionally there may be significant property damage.
 Caution	Indicates a potentially hazardous situation which, if not avoided, may result in minor or moderate injury or in property damage.

Even those items denoted by the caution symbol may lead to a serious outcome depending on the situation. Accordingly, be sure to observe all safety precautions.

Explanation of Symbols

This User's Manual uses the following symbols.

	The circle and slash symbol indicates operations that you must not do. The specific operation is shown in the circle and explained in text. This example indicates prohibiting disassembly.
	The triangle symbol indicates precautions and warnings. The specific operation is shown in the triangle and explained in text. This example indicates a precaution for electric shock.
	The triangle symbol indicates precautions and warnings. The specific operation is shown in the triangle and explained in text. This example indicates a general precaution.
	The filled circle symbol indicates operations that you must do. The specific operation is shown in the circle and explained in text. This example indicates a requirement for the ground.

Precautionary Information

- Illustrations contained in this manual sometimes depict conditions without covers and safety shields for the purpose of showing the details. When you use this product, be sure to install the covers and shields as specified and use the product according to this manual.
- If the product has been stored for an extended period of time, contact your OMRON sales representative.

Handling of Safety Products

If the functions of safety products cannot attain their full potential, it will result in minor or moderate injury, or may result in serious injury or death. When building the system, observe the following warnings and optimize safety product selection for your equipment and devices to ensure the integrity of the safety-related components.



● Setting Up a Risk Assessment System

The process of selecting these products should include the development and execution of a risk assessment system early in the design development stage to help identify potential dangers in your equipment and optimize safety product selection.

The following is an example of related international standards.

- ISO12100 General Principles for Design - Risk Assessment and Risk Reduction

● Protective Measure

When developing a safety system for the equipment and devices that use safety products, make every effort to understand and conform to the entire series of international and industry standards available, such as the examples given below.

The following are examples of related international standards.

- ISO12100 General Principles for Design - Risk Assessment and Risk Reduction
- IEC60204-1 Electrical Equipment of Machines - Part 1: General Requirements
- ISO13849-1, -2 Safety-related Parts of Control Systems
- ISO14119 Interlocking Devices Associated with Guards - Principles for Design and Selection
- IEC/TS 62046 Application of Protective Equipment to Detect the Presence of Persons

● Role of Safety Products

Safety products incorporate standardized safety functions and mechanisms, but the benefits of these functions and mechanisms are designed to attain their full potential only within properly designed safety-related systems. Make sure you fully understand all functions and mechanisms, and use that understanding to develop systems that will ensure optimal usage.

The following are examples of related international standards.

- ISO14119 Interlocking Devices Associated with Guards - Principles for Design and Selection
- ISO13857 Safety Distances to Prevent Hazard Zones being Reached by Upper and Lower Limbs

● Installing Safety Products

Qualified engineers must develop your safety-related system and install safety products in devices and equipment. Prior to machine commissioning, verify through testing that the safety products work as expected.

The following are examples of related international standards.

- ISO12100 General Principles for Design - Risk Assessment and Risk Reduction
- IEC60204-1 Electrical Equipment of Machines - Part 1: General Requirements
- ISO13849-1, -2 Safety-related Parts of Control Systems
- ISO14119 Interlocking Devices Associated with Guards - Principles for Design and Selection

● Observing Laws and Regulations

Safety products must conform to pertinent laws, regulations, and standards. Make sure that they are installed and used in accordance with the laws, regulations, and standards of the country where the devices and equipment incorporating these products are distributed.

● Observing Usage Precautions

Carefully read the specifications and precautions as well as all items in the Instruction Manual for your safety product to learn appropriate usage procedures. Any deviation from instructions will lead to unexpected device or equipment failure not anticipated by the safety-related system.

● Transferring Devices and Equipment

When you transfer devices and equipment, be sure to retain one copy of the Instruction Manual for safety devices and the User's Manual, and supply another copy with the device or equipment so the person receiving it will have no problems with operation and maintenance.

The following are examples of related international standards.

- ISO12100 General Principles for Design - Risk Assessment and Risk Reduction
- IEC60204-1 Electrical Equipment of Machines - Part 1: General Requirements
- ISO13849-1, -2 Safety-related Parts of Control Systems
- IEC62061 Functional Safety of Safety-related Electrical, Electronic and Programmable Electronic Control Systems
- IEC61508 Functional Safety of Electrical/Electronic/Programmable Electronic Safety-related Systems

Transporting and Unpacking



WARNING

Do not damage, pull, or put excessive stress or heavy objects on the cables.

Doing so may cause electric shock, malfunction, or burning.



Installation, Wiring and Maintenance



WARNING

Install the Servo Drive, Servomotor, and peripheral equipment before wiring.

Not doing so may cause electric shock.



Be sure to ground the 100-VAC or 200-VAC input model Servo Drive and Servomotor to 100 Ω or less, and the 400-VAC input model to 10 Ω or less.

Not doing so may cause electric shock.



Do not remove the front cover, terminal covers, cables, or peripheral equipment while the power is supplied.

Doing so may cause electric shock.



Before carrying out wiring or inspection, turn OFF the main circuit power and wait for at least the following specific time.

Not doing so may cause electric shock or burning.

10 minutes: R88D-1SN06F-ECT, R88D-1SN10F-ECT, R88D-1SN15F-ECT,
R88D-1SN20F-ECT, R88D-1SN30F-ECT

15 minutes: R88D-1SN01L-ECT, R88D-1SN02L-ECT, R88D-1SN01H-ECT,
R88D-1SN02H-ECT, R88D-1SN04H-ECT

20 minutes: R88D-1SN04L-ECT, R88D-1SN08H-ECT, R88D-1SN10H-ECT,
R88D-1SN15H-ECT, R88D-1SN20H-ECT, R88D-1SN30H-ECT



Do not damage, pull, or put excessive stress or heavy objects on the cables.

Doing so may cause electric shock, malfunction, or burning.



Use appropriate tools to wire terminals and connectors. Check that there is no short-circuit before use.

Not doing so may cause electric shock.



Connect the frame ground wire in the motor cable securely to the  or FG of the Servo Drive.

Not doing so may cause electric shock.



Operation Check











WARNING

Use the Servomotor and Servo Drive in a specified combination.

Not doing so may cause fire or equipment damage.



Usage

 WARNING	
<p>Do not enter the operating area during operation. Doing so may cause injury.</p>	
<p>Do not touch the Servo Drive radiator, Regeneration Resistor, or Servomotor while the power is supplied or for a while after the power is turned OFF because they get hot. Doing so may cause fire or a burn injury.</p>	
<p>Take appropriate measures to ensure that the specified power with the rated voltage is supplied. Be particularly careful in locations where the power supply is unstable. Not doing so may cause failure.</p>	
<p>When the power is restored after a momentary power interruption, the machine may restart suddenly. Do not come close to the machine when restoring power. Implement measures to ensure safety of people nearby even when the machine is restarted. Doing so may cause injury.</p>	
<p>Use appropriate tools to wire terminals and connectors. Check that there is no short-circuit before use. Not doing so may cause electric shock.</p>	
<p>Be sure to observe the radiator plate installation conditions that are specified in the manual. Not doing so may cause the Servo Drive or Servomotor to burn.</p>	
<p>If the load that exceeds the allowable range is installed, it may cause the dynamic brake to be damaged. Be sure to use the appropriate load. For the selection of the appropriate load, refer to <i>AC Servomotors/Servo Drives 1S-series with Built-in EtherCAT® Communications User's Manual (I586)</i>. Not doing so may cause the Servo Drive to be damaged.</p>	
<p>The dynamic brake is intended for the stop at the time of an error and therefore it has a short-time rating. If the dynamic brake is activated, provide an interval of 3 minutes or more before the next activation to prevent a circuit failure and burning of the Dynamic Brake Resistor.</p>	

Transporting and Unpacking



Caution

When transporting the Servo Drive, do not hold it by the cables or motor shaft.
Injury or failure may result.



Do not step on the Servo Drive or place heavy articles on it.
Injury may result.



Do not overload the product. (Follow the instructions on the product label.)
Injury or failure may result.



Be sure to observe the specified amount when piling up products.
Injury or failure may result.



The allowable number of piled-up products Servo Drive, Servomotor, Reactor:
Follow the instructions on the individual package.

External Regeneration Resistor: 12

External Regeneration Resistance Unit: 4

Noise Filter: 15

Wiring



Caution

Be careful about sharp parts such as the corner of the equipment when handling the Servo Drive and Servomotor.

Injury may result.



Precautions for Safe Use

General Precaution

- Do not store or install the Servo Drive in the following locations. Doing so may result in electric shock, fire, equipment damage, or malfunction.
 - Locations subject to direct sunlight
 - Locations subject to temperatures outside the range specified in the specifications
 - Locations subject to humidity outside the range specified in the specifications
 - Locations subject to condensation as the result of severe changes in temperature
 - Locations subject to corrosive or flammable gases
 - Locations subject to dust (especially iron dust) or salts
 - Locations subject to exposure to water, oil, or chemicals
 - Locations subject to shock or vibration
- Medical electronics such as cardiac pacemakers may malfunction or injury may result.
- Provide safety measures, such as a fuse, to protect against short circuiting of external wiring and failure of the Servo Drive. Fire may result.
- If an error occurs, remove the cause of the error and ensure safety, and then perform the error reset and restart the operation. Injury, equipment damage, or burning may result.

Wiring

- Use a robot cable for the wiring to separately install the Servo Drive and Servomotor to moving and fixed parts of the equipment. Equipment damage may result.
- Connect the Servo Drive to the Servomotor without a contactor, etc. Malfunction or equipment damage may result.

Precautions for Correct Use

General Precaution

- Take appropriate and sufficient countermeasures to provide shielding when installing systems in the following locations. Not doing so may result in failure.
 - Locations subject to static electricity or other forms of noise
 - Locations subject to strong electromagnetic fields
 - Locations subject to possible exposure to radioactivity
 - Locations close to power lines
- When lifting a 20-kg or more Servo Drive during moving or installation, always have two people lift the product by grasping a metal part other than the shaft. Do not grasp a plastic part. Injury or failure may result.
Relevant model: R88M-1M2K010T0-B□, R88M-1M3K010T-□, R88M-1M2K010C-B□, and R88M-1M3K010C-□

Transporting and Unpacking

- Check that the eye bolts are not loose after replacing them. If they are loose, the screws can come off and the Servomotor may fall during the transportation by the use of eye bolts. Do not put the human body under the Servomotor during the transportation.

Installation

- Be sure to observe the mounting direction. Failure may result.
- Provide the specified clearance between the Servo Drive and the inner surface of the control panel or other equipment. Fire or failure may result.
- Install the Servomotor, Servo Drive, and Regeneration Resistor on non-flammable materials such as metals. Fire may result.
- Do not apply strong impact on the motor shaft or Servo Drive. Failure may result.
- Do not touch the key grooves with bare hands if the Servomotor with shaft-end key grooves is used. Injury may result.
- Use non-magnetic mounting screws. Note also that the depth of any mounted screw does not reach the effective thread length. Equipment damage may result.
- Be sure to observe the allowable axial load for the Servomotor. Equipment damage may result.
- Install equipment to prevent crash and reduce shock.
Do not run the Servomotor outside the operable range by the use of the drive prohibition function such as overtravel.
Crash against the stroke edge may occur depending on stopping distance and equipment damage may result.
- Do not block the intake or exhaust openings. Do not allow foreign objects to enter the Servo Drive. Fire may result.
- Use the attached exclusive screws when you mount the Servo Drive to the Footprint-type Noise Filter. Electric shock or failure may result.

Wiring

- Wire the cables correctly and securely. Runaway motor, injury, or failure may result.
- Tighten the mounting screws, terminal block screws, and cable screws for the Servo Drive, Servomotor, and peripheral equipment to the specified torque. Failure may result.
- Use crimp terminals to wire screw type terminal blocks. Do not connect bare stranded wires directly to terminals blocks. Fire may result.
- Always use the power supply voltage specified in this document. Burning may result.
- Do not apply a commercial power supply directly to the Servomotor. Fire or failure may result.
- When constructing a system that includes safety functions, be sure you understand the relevant safety standards and all related information in user documentation, and design the system to comply with the standards. Injury or equipment damage may result.
- Disconnect all connections to the Servo Drive and Servomotor before attempting a megger test (insulation resistance measurement) on the Servo Drive or Servomotor. Not doing so may result in Servo Drive or Servomotor failure. Do not perform a dielectric strength test on the Servo Drive or Servomotor. Doing so may result in damage of the internal elements.
- Keep conductive or flammable foreign objects such as screws, metal pieces, and oil out of the Servo Drive and connectors. Pay particular attention to the connector on the top part of Servo Drive. Fire or electric shock may result.
- Carefully perform the wiring and assembling. Injury may result.
- Wear the protective equipment when installing or removing the main circuit connector, main circuit connector A, main circuit connector B, control power supply connector, or motor connector. Do not apply a force after the protrusion of the connector opener reaches the bottom dead center. (As a guide, do not apply a force of 100 N or more.)
- Design the configuration to cut off the main circuit power supply when the ERR signal (normally close contact) of the control output function is output (open).
- Do not block the intake or exhaust openings. Do not allow foreign objects to enter the Servo Drive. Fire may result.
- Do not apply excessive force to wire terminals and connectors. Injury or failure may result.

- Be sure to install surge suppressors when you connect a load with an induction coil such as a relay to the control output terminal.
Malfunction or equipment damage may result.

Adjustment

- Install an immediate stop device externally to the machine so that the operation can be stopped and the power supply is cut off immediately. Injury may result.
- Do not adjust or set parameters to extreme values, because it will make the operation unstable. Injury may result.
- Ensure that the Servomotor has a sufficient rigidity. Equipment damage or malfunction may result.
- If a problem occurs in serial communications or the computer during a test operation, you have no means to stop the Servomotor.
Connect an externally installed emergency stop switch, etc. to the Error Stop Input of the general-purpose input so that the Servomotor can be stopped without fail.
- When using the Servomotor with key, run the Servomotor in a state in which the key cannot jump out of the shaft.
Not doing so may result in hurting people around the equipment due to the jumping key.

Operation Check

- Before operating the Servo Drive in an actual environment, check if it operates correctly based on the newly set parameters. Equipment damage may result.
- Do not adjust or set parameters to extreme values, because it will make the operation unstable. Injury may result.
- Do not drive the Servomotor by the use of an external drive source. Fire may result.
- Check the newly set parameters for proper execution before actually using them.

Usage

- Tighten the mounting screws, terminal block screws, and cable screws for the Servo Drive, Servomotor, and peripheral equipment to the specified torque. Failure may result.
- Install a stopping device on the machine to ensure safety.
The holding brake is not a stopping device to ensure safety. Injury may result.
- Install an immediate stop device externally to the machine so that the operation can be stopped and the power supply is cut off immediately. Injury may result.
- Conduct a test operation after confirming that the equipment is not affected. Equipment damage may result.
- Do not use the built-in brake of the Servomotor for normal braking operation. Failure may result.
- After an earthquake, be sure to conduct safety checks. Electric shock, injury, or fire may result.
- Do not place flammable materials near the Servomotor, Servo Drive, or peripheral equipment. Fire may result.
- Connect an emergency stop (immediate stop) relay in series with the brake interlock output. Injury or failure may result.
- Do not use the cable when it is laying in oil or water. Electric shock, injury, or fire may result.
- Install safety devices to prevent idling or locking of the electromagnetic brake or the gear head, or leakage of grease from the gear head. Injury, damage, or taint damage result.
- If the Servo Drive fails, cut off the power supply to the Servo Drive at the power supply. Fire may result.
- Be sure to turn OFF the power supply when not using the Servo Drive for a prolonged period of time.
Not doing so may result in injury or malfunction.

- When constructing a system that includes safety functions, be sure you understand the relevant safety standards and all related information in user documentation, and design the system to comply with the standards. Injury or equipment damage may result.
- If the Servomotor is not controlled, it may not be possible to maintain the stop. To ensure safety, install a stop device. Equipment damage or injury may result.
- Periodically run the Servomotor approximately one rotation when the oscillation operation continues at a small angle of 45° or smaller. Servomotor failure may result.
- Immediately stop the operation and cut off the power supply when unusual smell, noise, smoking, abnormal heat generation, or vibration occurs. Not doing so may result in Servo Drive or Servomotor damage or burning.
- Use an appropriate External Regeneration Resistor. Install an external protective device such as temperature sensor to ensure safety when using the External Regeneration Resistor.

Maintenance

- After replacing the Servo Drive, transfer to the new Servo Drive all data needed to resume operation, before restarting operation. Equipment damage may result.
- Do not repair the Servo Drive by disassembling it. Electric shock or injury may result.

Location of Warning Display

The Servo Drive bears a warning label at the following location to provide handling warnings.

When you handle the Servo Drive, be sure to observe the instructions provided on this label.

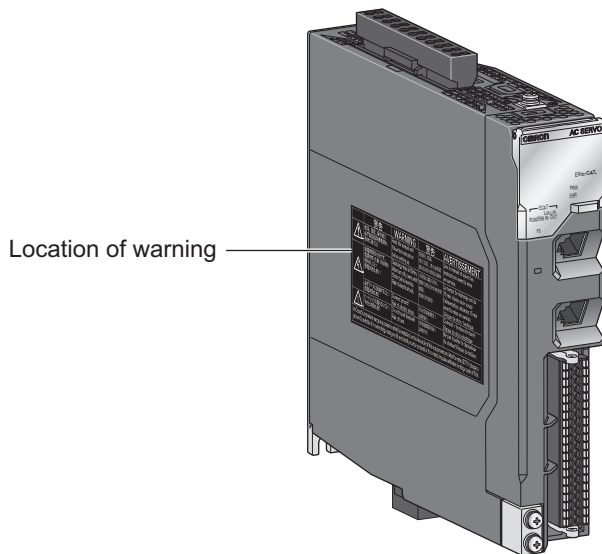

Instructions on Warning Display

	警告	WARNING	警告	AVERTISSEMENT
	使用、搬送、保守前に必ず取扱説明書を読み、指示に従うこと	Read the manual and follow the instruction before setting up.	在使用、安裝、維護之前，請務必按照使用說明書的指示操作	Lire le manuel et suivre les instructions avant la mise en service.
	放電時間は15分です。電源を切った後15分間は触らないこと！感電の恐れあり！	Discharge time is 15min. After turn off power, wait 15min before service. Risk of electric shock.	宅容放電需15分钟。切断电源15分钟内请勿触摸。有触电的危险！	Le temps de décharge est de 15 min. Après avoir coupé l'alimentation, attendez 15 min avant la mise en service. Risque de choc électrique.
	必ずアースに配線すること！感電の恐れあり	Connect ground! Risk of electric shock.	務必安裝接地線！以防触电	Connecter la mise à la terre! Risque de choc électrique
	ヒートシンクに触らないこと！やけどの恐れあり	Do not touch heatsink! Risk of burn.	請勿碰觸散熱器！以防灼傷	Ne pas toucher le dissipateur de chaleur! Risque de brûlure.
In Canada, transient surge suppression shall be installed on the line side of this equipment and shall be rated 277 V (phase to ground), suitable for overvoltage category III, and shall provide protection for a rated impulse withstand voltage peak of 6 kV.				

Note The above is an example of warning display.

Disposal

Dispose of the Servo Drive as industrial waste.

Items to Check After Unpacking

After you unpack the product, check the following items.

- Is this the model you ordered?
- Was there any damage sustained during shipment?

Servo Drive

Nameplate of Servo Drive

The model, rating and lot number of the 1S-series Servo Drive are given on the product nameplate.

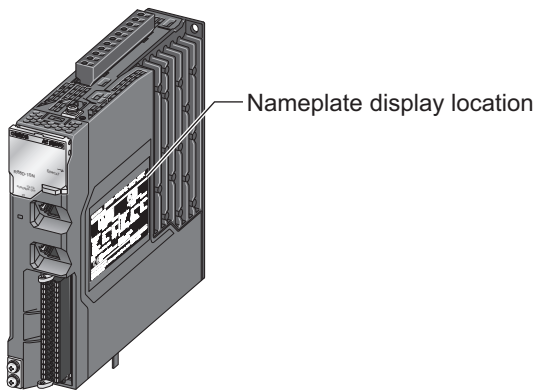

Name plate example: 100 VAC 100 W Servo Drive

omron R88D-1S01L-ECT Ver.1.0																											
AC SERVO DRIVE																											
INPUT		OUTPUT																									
Main Power Voltage	100-120V ϕ	0-120V ϕ																									
Phase	1 ϕ	3 ϕ																									
FLA	2.8A	1.6A																									
Frequency	50/60Hz	0-500Hz																									
Power	100W																										
Control Power	24V ϕ /1.2A																										
<table border="1"> <thead> <tr> <th colspan="2">INPUT</th> <th colspan="2">OUTPUT</th> </tr> </thead> <tbody> <tr> <td>Main Power Voltage</td> <td>100-120Vϕ</td> <td>0-120Vϕ</td> <td></td> </tr> <tr> <td>Phase</td> <td>1ϕ</td> <td>3ϕ</td> <td></td> </tr> <tr> <td>FLA</td> <td>2.8A</td> <td>1.6A</td> <td></td> </tr> <tr> <td>Frequency</td> <td>50/60Hz</td> <td>0-500Hz</td> <td></td> </tr> <tr> <td>Control Power</td> <td>24Vϕ/1.2A</td> <td></td> <td></td> </tr> </tbody> </table>				INPUT		OUTPUT		Main Power Voltage	100-120V ϕ	0-120V ϕ		Phase	1 ϕ	3 ϕ		FLA	2.8A	1.6A		Frequency	50/60Hz	0-500Hz		Control Power	24V ϕ /1.2A		
INPUT		OUTPUT																									
Main Power Voltage	100-120V ϕ	0-120V ϕ																									
Phase	1 ϕ	3 ϕ																									
FLA	2.8A	1.6A																									
Frequency	50/60Hz	0-500Hz																									
Control Power	24V ϕ /1.2A																										
OMRON CORPORATION SHIKOKU HORIKAWA, SHIMOGYO-KU, KYOTO 600-8530 JAPAN MADE IN JAPAN		Lot No. DDMYY□xxxx																									

Servo Drive model

Servo Drive rating

Lot number and serial number*1

*1. The notifications and their meanings are explained below.

Notation: Lot No. DDMYY□xxxx

DDMY: Lot number, □: For use by OMRON, xxxx: Serial number

"M" gives the month (1 to 9: January to September, X: October, Y: November, Z: December)

Accessories of Servo Drive

This product comes with the following accessories.

- INSTRUCTION MANUAL × 1 copy
- Warning label × 1 sheet
- General Compliance Information and instructions for EU × 1 copy
- Attached connectors (Depends on the model. Refer to the following table.)

When UL/CSA certification is required, attach the warning label to a place around the Servo Drive.

Connectors, mounting screws, mounting brackets, and other accessories other than those in the table below are not supplied. They must be prepared by the customer.

If any item is missing or a problem is found such as Servo Drive damage, contact the OMRON dealer or sales office where you purchased your product.

Specifications		Control I/O connector (CN1)	Brake interlock connector (CN12)	Main circuit connector and main circuit connector A (CNA)
Single-phase/3-phase 200 VAC	100 W	Included*1	Included	Included*2 *4
	200 W			
	400 W			
	750 W			
	1.5 kW			Included*3 *4
3-phase 200 VAC	1 kW			Included*2 *4

*1. Four short-circuit wires are connected to the connector.

*2. The connector with 11 terminals is included. Two short-circuit wires are connected.

*3. The connector with 6 terminals is included. One short-circuit wire is connected.

*4. One opener is included.

Specifications		Main circuit connector B (CNB)	Motor connector (CNC)	Control power supply connector (CND)
Single-phase/3-phase 200 VAC	100 W	---	Included*2	---
	200 W			
	400 W			
	750 W			
	1.5 kW		Included*1	
3-phase 200 VAC	1 kW	---	Included*2	---

*1. One short-circuit wire is connected to the connector.

*2. The connector with 3 terminals is included.

*3. The connector with 4 terminals is included.

*4. One opener is included.

Servomotor

The model, rating and serial number of the 1S-series Servomotor are given on the product nameplate.

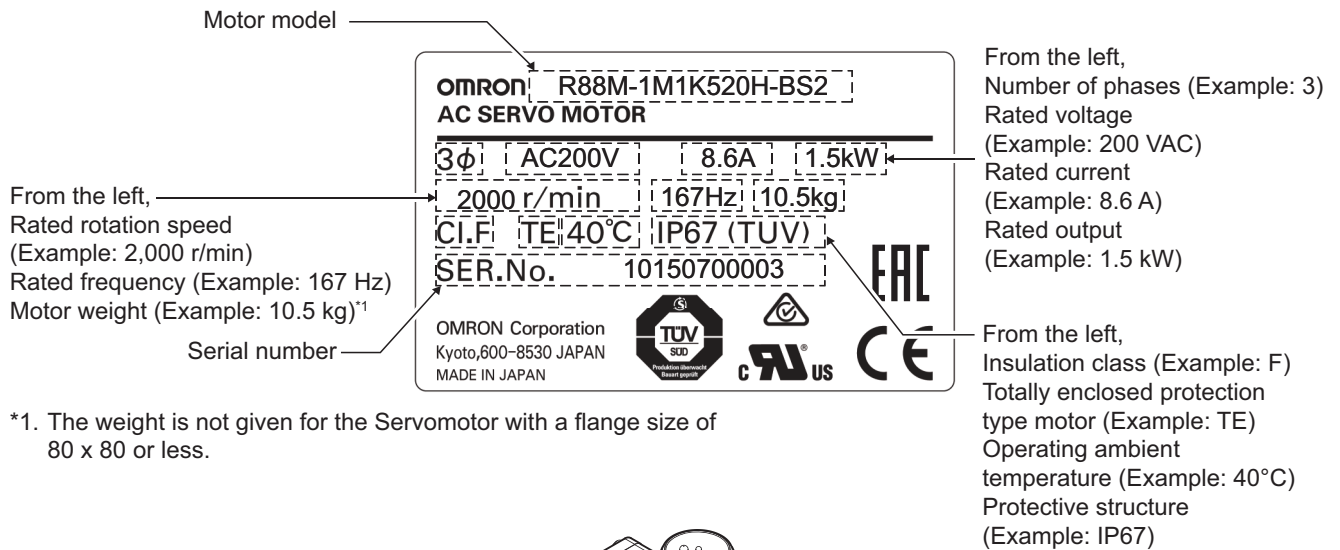

*1. The weight is not given for the Servomotor with a flange size of 80 x 80 or less.

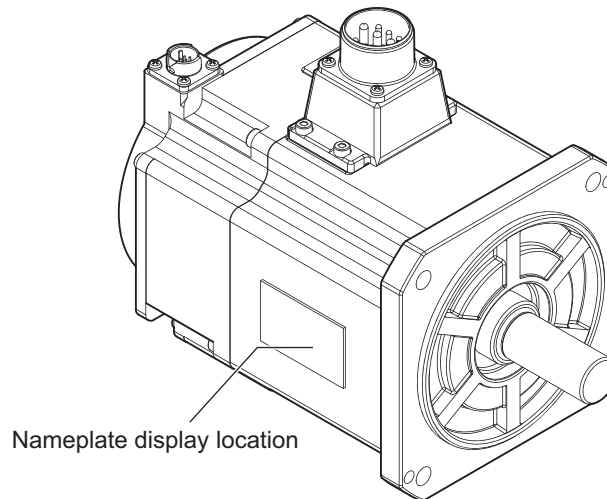

Nameplate display location

Related Manuals

The following are the manuals related to this manual. Use these manuals for reference.

Manual name	Cat. No.	Model numbers	Application	Description
AC Servomotors/Servo Drives 1S-series with Built-in EtherCAT® Communications User's Manual	I586	R88M-1L□□/-1M□ R88D-1SN□-ECT	Learning the functionality and performance of 1S-series Servo Drives. Mainly information below is provided. <ul style="list-style-type: none"> • EtherCAT Communications • Basic Control Functions • Applied Functions • Safety Function • Adjustment Functions 	An outline to the entire 1S-series system is provided along with the following information on the Servomotors (with absolute encoder specifications)/Servo Drives. <ul style="list-style-type: none"> • Features and system configuration • Outline • Names and functions • General specifications • Installation and wiring • Maintenance and inspections
NX-series CPU Unit Hardware User's Manual	W535	NX701-□□□□	Learning the basic specifications of the NX-series CPU Units, including introductory information, designing, installation, and maintenance. Mainly hardware information is provided.	An introduction to the entire NX-series system is provided along with the following information on the CPU Unit. <ul style="list-style-type: none"> • Features and system configuration • Introduction • Part names and functions • General specifications • Installation and wiring • Maintenance and inspection Use this manual together with the <i>NJ-series CPU Unit Software User's Manual</i> (Cat. No. W501).
NJ-series CPU Unit Hardware User's Manual	W500	NJ501-□□□□ NJ301-□□□□ NJ101-□□□□	Learning the basic specifications of the NJ-series CPU Units, including introductory information, designing, installation, and maintenance. Mainly hardware information is provided.	An introduction to the entire NJ-series system is provided along with the following information on the CPU Unit. <ul style="list-style-type: none"> • Features and system configuration • Introduction • Part names and functions • General specifications • Installation and wiring • Maintenance and inspection Use this manual together with the <i>NJ-series CPU Unit Software User's Manual</i> (Cat. No. W501).

Manual name	Cat. No.	Model numbers	Application	Description
NJ/NX-series CPU Unit Software User's Manual	W501	NX701-□□□□ NX1P2-□□□□ NJ501-□□□□ NJ301-□□□□ NJ101-□□□□	Learning how to program and set up an NJ/NX-series CPU Unit. Mainly software information is provided.	The following information is provided on a Controller built with an NJ/NX-series CPU Unit. <ul style="list-style-type: none"> • CPU Unit operation • CPU Unit features • Initial settings • Programming based on IEC 61131-3 language specifications Use this manual together with the <i>NX-series CPU Unit Hardware User's Manual</i> (Cat. No. W535) or <i>NJ-series CPU Unit Hardware User's Manual</i> (Cat. No. W500).
NJ/NX-series CPU Unit Motion Control User's Manual	W507	NX701-□□□□ NX1P2-□□□□ NJ501-□□□□ NJ301-□□□□ NJ101-□□□□	Learning about motion control settings and programming concepts.	The settings and operation of the CPU Unit and programming concepts for motion control are described. When programming, use this manual together with the <i>NX-series CPU Unit Hardware User's Manual</i> (Cat. No. W535) or <i>NJ-series CPU Unit Hardware User's Manual</i> (Cat. No. W500) and with the <i>NJ/NX-series CPU Unit Software User's Manual</i> (Cat. No. W501).
NX-series Safety Control Units User's Manual	Z930	NX-SL□□□□ NX-SI□□□□ NX-SO□□□□	Learning how to use the NX-series Safety Control Units.	Describes the hardware, setup methods and functions of the NX-series Safety Control Units.
Sysmac Studio Version 1 Operation Manual	W504	SYSMAC-SE2 □□□	Learning about the operating procedures and functions of the Sysmac Studio.	Describes the operating procedures of the Sysmac Studio.
Sysmac Studio Drive Functions Operation Manual	I589	SYSMAC-SE2 □□□	Learning how to set up and adjust the Servo Drives.	Describes the operating procedures of the Sysmac Studio.
SYSMAC CJ-series Position Control Unit Operation Manual	W487	CJ1W-NC281 CJ1W-NC481 CJ1W-NC881 CJ1W-NCF81 CJ1W-NC482 CJ1W-NC882 CJ1W-NCF82	Learning about the NC Units (CJ1W-NC281/ 481/ 881/ F81/ 482/ 882/ F82).	Describes the setup methods and operating procedures of the NC Units.
G9SP-series Safety Controller Operation Manual	Z922	G9SP-N10S G9SP-N10D G9SP-N20S	Learning how to use the G9SP-series safety Controllers.	Describes the hardware, setup methods and functions of the G9SP-series safety Controllers.

Terminology

Term	Abbreviation	Description
CAN application protocol over EtherCAT	CoE	A CAN application protocol service implemented on EtherCAT.
CAN in Automation	CiA	CiA is the international users' and manufacturers' group that develops and supports higher-layer protocols.
Device Profile	---	Collection of device dependent information and functionality providing consistency between similar devices of the same device type.
Distributed Clocks	DC	Method to synchronize slaves and maintain a global time base.
EtherCAT Slave Controller	ESC	A controller for EtherCAT slave communication.
EtherCAT Slave Information	ESI	An XML file that contains setting information for an EtherCAT slave.
EtherCAT State Machine	ESM	An EtherCAT communication state machine.
EtherCAT Technology Group	ETG	The ETG is a global organization in which OEM, End Users and Technology Providers join forces to support and promote the further technology development.
Fieldbus Memory Management Unit	FMMU	Single element of the fieldbus memory management unit: one correspondence between a coherent logical address space and a coherent physical memory location.
Index	---	Address of an object within an application process.
Object	---	Abstract representation of a particular component within a device, which consists of data, parameters, and methods.
Object Dictionary	OD	Data structure addressed by Index and Subindex that contains description of data type objects, communication objects and application objects.
Physical Device Internal Interface	PDI	A series of elements to access data link services from the application layer.
Power Drive System	PDS	A power drive system consisting of a Servo Drive, an inverter, and other components.
Process Data	---	Collection of application objects designated to be transferred cyclically or acyclically for the purpose of measurement and control.
Process Data Object	PDO	Structure described by mapping parameters that contain one or several process data entities.
Receive PDO	RxPDO	A process data object received by an EtherCAT slave.
safe state	---	The status of a device or piece of equipment when the risk of danger to humans has been reduced to an acceptable level.
safety control	---	A type of control that uses devices, functions, and data that are designed with special safety measures.
Safety over EtherCAT	FSoE	A system to communicate for the functional safety over EtherCAT.
safety process data communications	---	A type of I/O data communications that is used for safety control purposes.

Term	Abbreviation	Description
safety reaction time	---	The time required for the system to enter a safe state in a worst-case scenario after the occurrence of a safety-related input (press of an emergency stop pushbutton switch, interruption of a light curtain, opening of a safety door, etc.) or device failure. The reaction time of the system includes the reaction times of sensors and actuators, just like the reaction time for a Controller or network.
Service Data Object	SDO	CoE asynchronous mailbox communications where all objects in the object dictionary can be read and written.
Slave Information Interface	SII	Slave information stored in the nonvolatile memory of each slave.
standard control	---	A type of control that use devices, functions, and data that are designed for general control purposes. This term is used to differentiate from a safety control.
Subindex	---	Sub-address of an object within the object dictionary.
Sync Manager	SM	Collection of control elements to coordinate access to concurrently used objects.
Transmit PDO	TxPDO	A process data object sent from an EtherCAT slave.

Revision History

The manual revision code is a number appended to the end of the catalog number found in the front and back cover.

Example

Cat. No.	I619-E1-01
-----------------	-------------------

↑
Revision code

Revision code	Date	Revised content
01	April 2018	Original production

1

Features and System Configuration

This section explains the features of the Servo Drive and name of each part. For the names and functions, system block diagram, and procedures to start operation of Servo Drives, refer to the *AC Servomotors/Servo Drives 1S-series with Built-in EtherCAT® Communications User's Manual (I586)*.

1-1	Outline	1-2
1-1-1	Features of 1S-series Servo Drives	1-2
1-1-2	EtherCAT	1-3
1-1-3	Object Dictionary	1-4
1-2	System Configuration	1-5
1-3	Names and Functions	1-6
1-3-1	Servomotor Part Names	1-6
1-3-2	Servomotor Functions	1-7
1-4	Applicable Standards	1-8
1-4-1	EU Directives	1-8
1-4-2	UL and CSA Standards	1-9
1-4-3	Korean Radio Regulations (KC)	1-9
1-4-4	SEMI F47	1-10
1-4-5	Australian EMC Labeling Requirements (RCM)	1-10
1-5	Unit Versions	1-11
1-5-1	Confirmation Method	1-11
1-5-2	Unit Versions and Sysmac Studio Versions	1-11

1-1 Outline

The 1S-series Servo Drives with Built-in EtherCAT communications support 100-Mbps EtherCAT.

When you use the 1S-series Servo Drive with a Machine Automation Controller NJ/NX-series CPU Unit or Position Control Unit with EtherCAT (Model: CJ1W-NC□8□), you can construct a high-speed and sophisticated positioning control system.

You need only one communications cable to connect the Servo Drive and the Controller. Therefore, you can realize a position control system easily with reduced wiring effort.

With adjustment functions, adaptive notch filter, notch filter, and damping control, you can set up a system that provides stable operation by suppressing vibration in low-rigidity machines.

Moreover, with the two-degree-of-freedom (TDF) control structure, you can easily adjust high-precision positioning.

1-1-1 Features of 1S-series Servo Drives

The 1S-series Servo Drives have the following features.

Optimal Functionality and Operability by Standardizing Specifications

As a Sysmac Device, 1S-series Servo Drives with built-in EtherCAT communications is designed to achieve optimum functionality and ease of operation when it is used together with the NJ/NX-series Machine Automation Controller and the Sysmac Studio Automation Software.

Sysmac Device is a generic term for OMRON control devices such as an EtherCAT Slave, designed with unified communications specifications and user interface specifications.

Data Transmission Using EtherCAT Communications

Combining the 1S-series Servo Drive with a Machine Automation Controller NJ/NX-series CPU Unit or Position Control Unit with EtherCAT (Model: CJ1W-NC□8□) enables you to exchange all position information with the controller in high-speed data communications.

Since the various control commands are transmitted via data communications, Servomotor's operational performance is maximized without being limited by interface specifications such as the response frequency of the encoder feedback pulses.

You can use the Servo Drive's various control parameters and monitor data on a host controller, and unify the system data for management.

EtherCAT Communications Cycle of 125 μ s

Combination with an NX7 Machine Automation Controller enables high-speed and high-precision motion control at the communications cycle of 125 μ s.

High Equipment Utilization Efficiency with 400-V Models

The 400-V models are provided for use with large equipment, at overseas facilities and in wide-ranging applications and environment. Since the utilization ratio of facility equipment also increases, the TCO (Total Cost of Ownership) will come down.

Safe Torque OFF (STO) Function to Ensure Safety

You can cut off the motor current to stop the motor based on a signal from an emergency stop button or other safety equipment. This can be used for an emergency stop circuit that is compliant with safety standards without using an external contactor. Even during the torque OFF status, the present position of the motor is monitored by the control circuits to eliminate the need to perform the homing at the time of restart.

Achievement of Safety on EtherCAT Network

You can use NX-series Safety Control Units to integrate safety controls in a sequence and motion control system.

The 1S-series Servo Drive supports the FSoE (Safety over EtherCAT) protocol as the safety communications. You can build the safety system that uses the STO function from the safety controller on the EtherCAT network.

Suppressing Vibration of Low-rigidity Machines During Acceleration/Deceleration

The damping control function suppresses vibration of low-rigidity machines or devices whose tips tend to vibrate. The function can also be used for damping control for larger constructions as it supports vibration ranging from 0.5 to 300 Hz. You can maximize the performance of the Servomotor by adjusting the trade-off between the damping time and the amount of peak control.

Easy Adjustment with TDF Control Structure

The TDF control structure allows you to separately adjust the amount of overshooting and the resistance against disturbance. With this feature, you can easily achieve high-precision positioning, which is difficult to achieve with the one-degree-of-freedom (ODF) control.

1-1-2 EtherCAT

EtherCAT is an open high-speed industrial network system that conforms to Ethernet (IEEE 802.3). Each node achieves a short communications cycle time by transmitting Ethernet frames at high speed. A mechanism that allows sharing clock information enables high-precision synchronization control with low communications jitter.

1-1-3 Object Dictionary

1S-series Servo Drives with Built-in EtherCAT Communications use the object dictionary for CAN application protocol over EtherCAT (CoE) as a base for communications.

An object is an abstract representation of a particular component within a device, which consists of data, parameters, and methods.

An object dictionary is a data structure that contains description of data type objects, communication objects and application objects.

All objects are assigned four-digit hexadecimal indexes in the areas shown in the following table.

Index (hex)	Area	Description
0000 to 0FFF	Data Type Area	Definitions of data types.
1000 to 1FFF	CoE Communications Area	Definitions of objects that can be used by all servers for designated communications.
2000 to 2FFF	Manufacturer Specific Area 1	Objects with common definitions for all OMRON products.
3000 to 5FFF	Manufacturer Specific Area 2	Objects with common definitions for all 1S-series Servo Drives (servo parameters). ^{*1}
6000 to DFFF	Device Profile Area	Variables defined in the Servo Drive's CiA402 drive profile.
E000 to EFFF	Device Profile Area 2	Objects defined in the Servo Drive's FSoE CiA402 slave connection.
F000 to FFFF	Device Area	Objects defined in a device.

*1. For details on servo parameters, refer to *Section 5 Details on Servo Parameters*.

1-2 System Configuration

The system configuration for a 1S-series Servo Drive with Built-in EtherCAT Communications connected to an Incremental Encoder Type Servomotor is shown below.

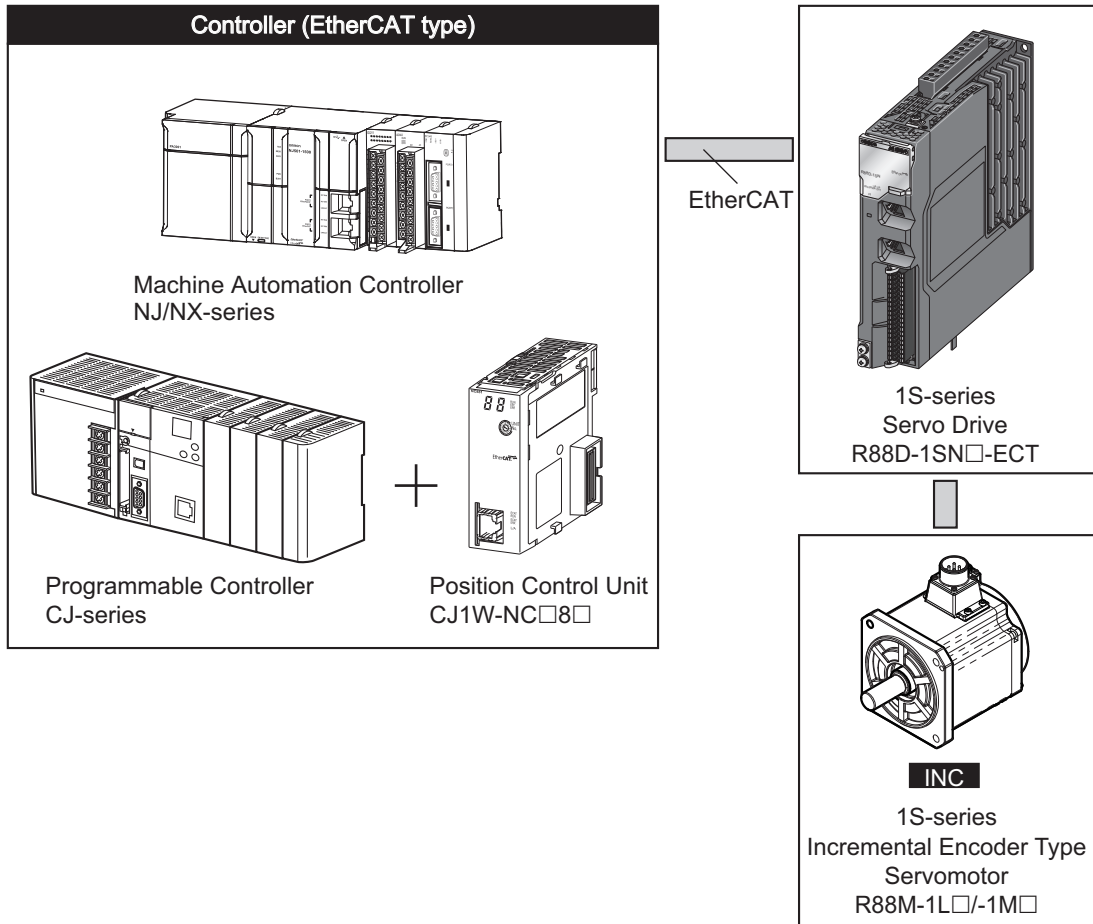

1-3 Names and Functions

This section describes the names and functions of Servo Drive parts.

1-3-1 Servomotor Part Names

The Servomotor part names are given below.

Flange Size of 80 x 80 or less

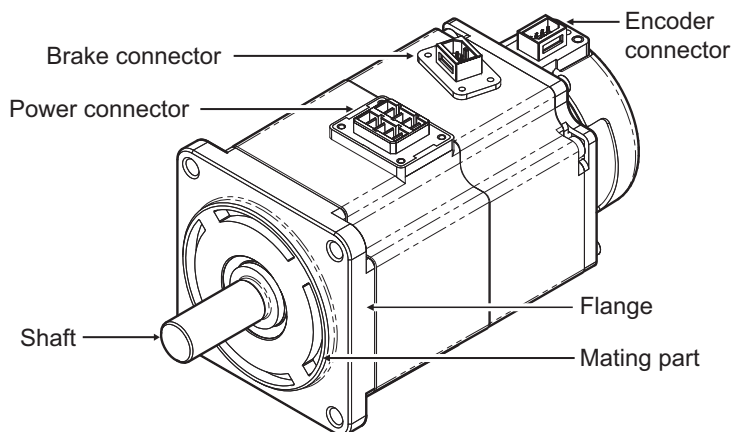

200 VAC 200 W Servomotors (with Brake)

Flange Size of 100 x 100 or more

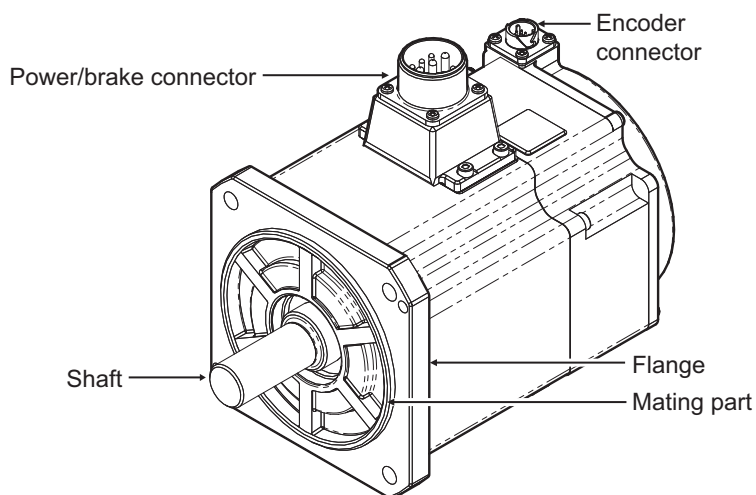

200 VAC 1.5 kW Servomotors (with Brake)

1-3-2 Servomotor Functions

The functions of each part of the Servomotor are described below.

Shaft

The load is mounted on this shaft.

The direction which is in parallel with the shaft is called the thrust direction, and the direction which is perpendicular to the shaft is called the radial direction.

Flange

Used for mounting the Servomotor on the equipment.

Fit the mating part into the equipment and use the mounting holes to screw the Servomotor.

Power Connector

Used for supplying power to the phase U, V, and W of the Servomotor.

For Servomotors with a brake and flange size of 100 x 100 or more, the pins for power and brake are set on the same connector.

Encoder Connector

Used for supplying power to the encoder of the Servomotor and communicating with the Servo Drive.

Brake Connector

Used for supplying power to the brake coil of the Servomotor.

This part is attached only to the Servomotors with a brake and flange size of 80 x 80 or less.

1-4 Applicable Standards

This section describes applicable standards.

1-4-1 EU Directives

The 1S-series Servomotors, Servo Drives, and Footprint-type Noise Filters conform to the following standards.

EU Directives	Product	Applicable standards
EMC Directive	Servo Drives	EN61800-3 second environment, C3 Category (EN 61326-3-1 Functional Safety)
Low Voltage Directive	Servo Drives	EN 61800-5-1
	Servomotors	EN 60034-1/-5
	Footprint-type Noise Filters	EN 60939-2
Machinery Directive	Servo Drives	EN ISO 13849-1 (Cat.3) EN 61508 EN 62061 EN 61800-5-2

Note To conform to EMC Directives, install the Servo Drive and Servomotor under the conditions described in 4-3 *Wiring Conforming to EMC Directives* on page 4-8.

The Servo Drives and Servomotors comply with EN 61800-5-1 as long as the following installation conditions (a) and (b) are met.

- (a) Use the Servo Drive in pollution degree 2 or 1 environment as specified in IEC 60664-1.
Example: Installation inside an IP54 control panel.
- (b) Be sure to connect a fuse, which complies with IEC 60269-1 CLASS gG, between the power supply and noise filter.
Select a fuse from the following table.

Servo Drive model	Fuse
R88D-1SN01H-ECT	CLASS gG 16A
R88D-1SN02H-ECT	CLASS gG 16A
R88D-1SN04H-ECT	CLASS gG 16A
R88D-1SN08H-ECT	CLASS gG 16A
R88D-1SN10H-ECT	CLASS gG 16A
R88D-1SN15H-ECT	CLASS gG 40A

1-4-2 UL and CSA Standards

The 1S-series Servomotors, Servo Drives, and Footprint-type Noise Filters conform to the following standards.

Standard	Product	Applicable standards	File number
UL standards	Servo Drives	UL 61800-5-1	E179149
	Servomotors	UL 1004-1, UL 1004-6	E331224
	Footprint-type Noise Filters	UL1283	E191135
CSA standards*1	Servo Drives	CSA C22.2 No. 274	E179149
	Servomotors	CSA C22.2 No. 100	E331224

*1. IN CANADA, TRANSIENT SURGE SUPPRESSION SHALL BE INSTALLED ON THE LINE SIDE OF THIS EQUIPMENT AND SHALL BE RATED 277 V (PHASE TO GROUND), SUITABLE FOR OVERVOLTAGE CATEGORY III, AND SHALL PROVIDE PROTECTION FOR A RATED IMPULSE WITHSTAND VOLTAGE PEAK OF 6 KV

The Servo Drives and Servomotors comply with UL 61800-5-1 as long as the following installation conditions (a) and (b) are met.

(a) Use the Servo Drive in pollution degree 2 or 1 environment as specified in IEC 60664-1.

Example: Installation inside an IP54 control panel.

(b) Be sure to connect a fuse, which is a UL-listed product with LISTED and  mark, between the power supply and noise filter.

Select the fuse from the following table.

Use copper wiring with a temperature rating of 75°C or higher.

Servo Drive model	Fuse
R88D-1SN01H-ECT	UL CLASS RK5 15 A
R88D-1SN02H-ECT	UL CLASS RK5 15 A
R88D-1SN04H-ECT	UL CLASS RK5 15 A
R88D-1SN08H-ECT	UL CLASS RK5 15 A
R88D-1SN10H-ECT	UL CLASS RK5 15 A
R88D-1SN15H-ECT	UL CLASS RK5 40 A

1-4-3 Korean Radio Regulations (KC)

- Observe the following precaution if you use this product in Korea.

A 급 기기 (업무용방송통신기자재)

이 기기는 업무용(A 급) 전자파작합기기로서 판매자 또는 사용자는 이 점을 주의하시기 바라며, 가정외의 지역에서 사용하는 것을 목적으로 합니다.

Class A Device (Broadcasting Communications Device for Office Use)

This device obtained EMC registration for office use (Class A), and it is intended to be used in places other than homes. Sellers and/or users need to take note of this.

- The 1S-series Servo Drives comply with the Korean Radio Regulations (KC).
- The 1S-series Servomotors are exempt from the Korean Radio Regulations (KC).

1-4-4 SEMI F47

- The main power supply inputs can conform to the SEMI F47 standard for momentary power interruptions (voltage sag immunity) for no-load operation.
- This standard applies to semiconductor manufacturing equipment.



Precautions for Correct Use

- This standard does not apply to the 24-VDC control power input. Use the power supply.
 - This standard does not apply to single-phase 100-V Servo Drives.
 - Be sure to perform evaluation tests for SEMI F47 compliance in the entire machine and system.
-

1-4-5 Australian EMC Labeling Requirements (RCM)

- The 1S-series Servo Drives comply with the Australian EMC Labeling Requirements (RCM).
- The 1S-series Servomotors comply with the Australian EMC Labeling Requirements (RCM).

1-5 Unit Versions

The 1S-series Servo Drive uses unit versions.

Unit versions are used to manage differences in supported functions due to product upgrades, etc.

1-5-1 Confirmation Method

The unit version of 1S-series is displayed at the location shown below.

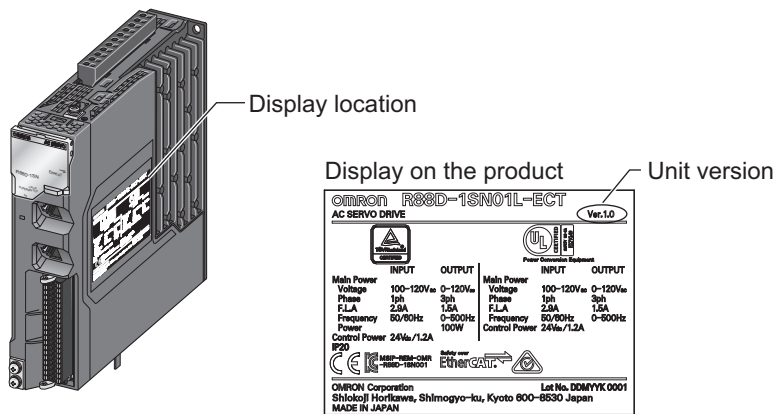

1-5-2 Unit Versions and Sysmac Studio Versions

For 1S-series Incremental Encoder Type Servomotors, you must use the 1S-series Servo Drives unit version 1.2 or later, and Sysmac Studio version 1.22 or higher.

2

Models and External Dimensions

This section explains the models of Servomotors and peripheral devices, and provides the external dimensions and mounting dimensions.

For the models and external dimensions of Servo Drives, refer to the *AC Servomotors/Servo Drives 1S-series with Built-in EtherCAT® Communications User's Manual (I586)*.

2-1	Servo System Configuration	2-2
2-2	How to Read Model Numbers	2-4
2-2-1	Servomotor	2-4
2-3	Model Tables	2-5
2-3-1	Servomotor Model Tables	2-5
2-3-2	Servo Drive and Servomotor Combination Tables	2-6
2-3-3	Servomotor and Decelerator Combination Tables	2-7
2-3-4	Cable and Connector Model Tables	2-7
2-4	External and Mounting Dimensions	2-12
2-4-1	Servomotor Dimensions	2-12

2-1 Servo System Configuration

This section shows the Servo system configuration that consists of Controllers, Servo Drives, Servomotors and other devices.

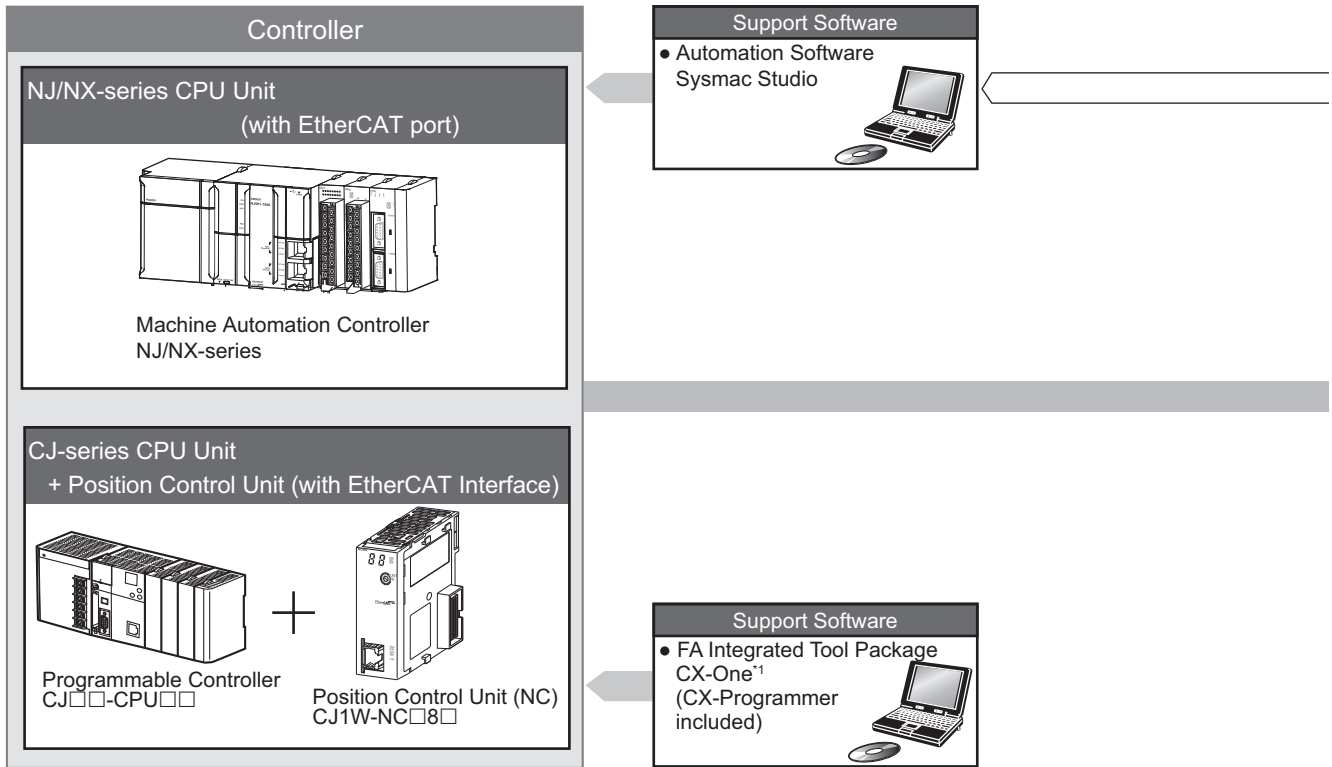

*1. You cannot use the CX-One to make the settings of 1S-series Servo Drives. Obtain the Sysmac Studio.

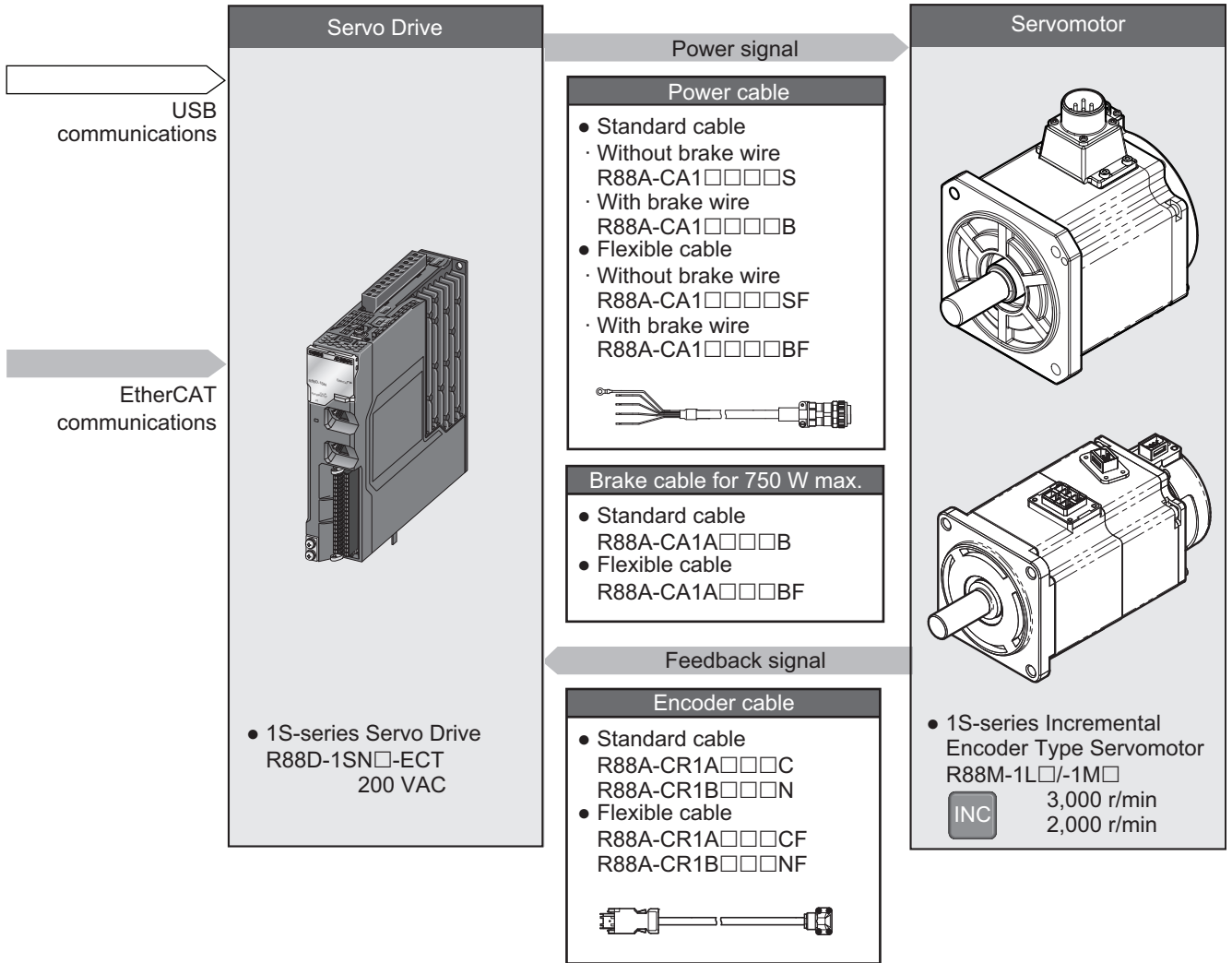

2-2 How to Read Model Numbers

This section describes how to read and understand the model numbers of Servo Drives and Servomotors.

2-2-1 Servomotor

The Servomotor model number tells the Servomotor type, rated output, rated rotation speed, voltage, etc.

R88M-1M10030H-BOS2

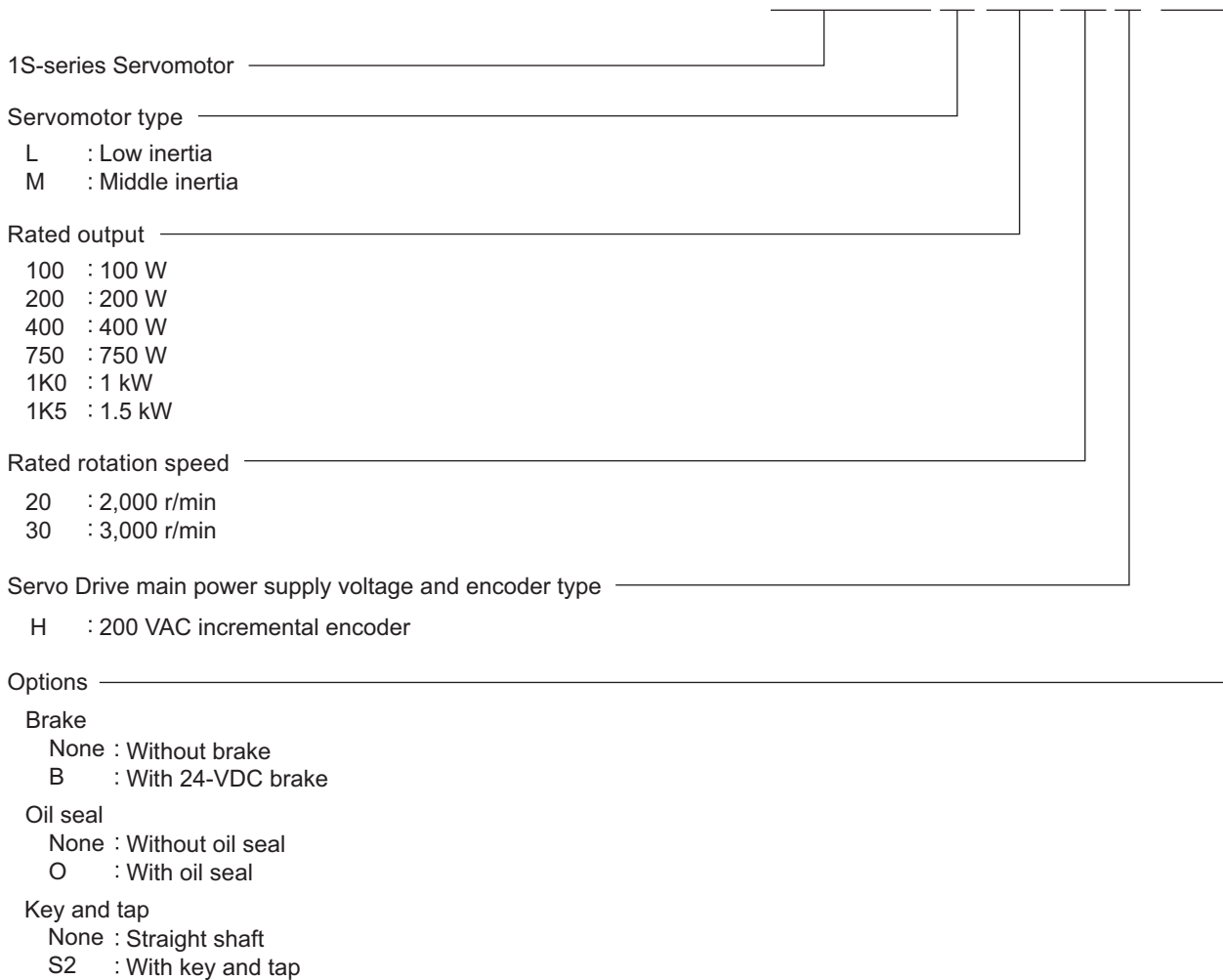

Combinations of Options

	Without oil seal		With oil seal	
	Straight shaft	With key and tap	Straight shaft	With key and tap
Without brake	None	-S2	-O	-OS2
With brake	-B	-BS2	-BO	-BOS2

2-3 Model Tables

This section lists the models of Servo Drives, Servomotors, cables, connectors, peripheral devices, etc. in the tables.

2-3-1 Servomotor Model Tables

The following tables list the Servomotor models by the rated motor speed.

3,000-r/min Servomotors

Specifications			Model				Reference
			Without oil seal		With oil seal		
			Straight shaft	With key and tap	Straight shaft	With key and tap	
Without brake	200 VAC	100 W	---	R88M- 1M10030H-S2	---	---	P. 2-12
		200 W	---	R88M- 1M20030H-S2	---	---	P. 2-14
		400 W	---	R88M- 1M40030H-S2	---	---	P. 2-14
		750 W	---	R88M- 1M75030H-S2	---	---	P. 2-16
		1 kW	---	R88M- 1L1K030H-S2	---	---	P. 2-18
		1.5 kW	---	R88M- 1L1K530H-S2	---	---	P. 2-18
With brake	200 VAC	100 W	---	R88M- 1M10030H-BS2	---	---	P. 2-13
		200 W	---	R88M- 1M20030H-BS2	---	---	P. 2-15
		400 W	---	R88M- 1M40030H-BS2	---	---	P. 2-15
		750 W	---	R88M- 1M75030H-BS2	---	---	P. 2-17
		1 kW	---	R88M- 1L1K030H-BS2	---	---	P. 2-19
		1.5 kW	---	R88M- 1L1K530H-BS2	---	---	P. 2-19

2,000-r/min Servomotors

Specifications			Model				Reference
			Without oil seal		With oil seal		
			Straight shaft	With key and tap	Straight shaft	With key and tap	
Without brake	200 VAC	1 kW	---	R88M-1M1K020H-S2	---	---	P. 2-20
		1.5 kW	---	R88M-1M1K520H-S2	---	---	P. 2-20
With brake	200 VAC	1 kW	---	R88M-1M1K020H-BS2	---	---	P. 2-21
		1.5 kW	---	R88M-1M1K520H-BS2	---	---	P. 2-21

2-3-2 Servo Drive and Servomotor Combination Tables

The following tables show the possible combinations of 1S-series Servo Drives and Servomotors. The Servomotors and Servo Drives can only be used in the listed combinations. “□” at the end of the motor model number is for options, such as the shaft type and brake.

3,000-r/min Servomotors and Servo Drives

Main circuit power supply voltage	Servomotor rated output	Servomotor	Servo Drive
Single-phase/3-phase 200 VAC	100 W	R88M-1M10030H-□	R88D-1SN01H-ECT
	200 W	R88M-1M20030H-□	R88D-1SN02H-ECT
	400 W	R88M-1M40030H-□	R88D-1SN04H-ECT
	750 W	R88M-1M75030H-□	R88D-1SN08H-ECT
3-phase 200 VAC	1 kW	R88M-1L1K030H-□	R88D-1SN10H-ECT
Single-phase/3-phase 200 VAC	1.5 kW	R88M-1L1K530H-□	R88D-1SN15H-ECT

2,000-r/min Servomotors and Servo Drives

Main circuit power supply voltage	Servomotor rated output	Servomotor	Servo Drive
3-phase 200 VAC	1 kW	R88M-1M1K020H-□	R88D-1SN10H-ECT
Single-phase/3-phase 200 VAC	1.5 kW	R88M-1M1K520H-□	R88D-1SN15H-ECT

2-3-3 Servomotor and Decelerator Combination Tables

You cannot use a 1S-series Incremental Encoder Type Servomotor in combination with a Decelerator.

2-3-4 Cable and Connector Model Tables

The following tables list the models of cables and connectors. The cables include encoder cables, motor power cables, and brake cables.

Encoder Cables (Standard Cable)

Applicable Servomotor		Model	
200 V	3,000-r/min Servomotors of 100 W, 200 W, 400 W, and 750 W	3 m	R88A-CR1A003C
		5 m	R88A-CR1A005C
		10 m	R88A-CR1A010C
		15 m	R88A-CR1A015C
		20 m	R88A-CR1A020C
		30 m	R88A-CR1A030C
		40 m	R88A-CR1A040C
		50 m	R88A-CR1A050C
	3,000-r/min Servomotors of 1kW or more 2,000-r/min Servomotors	3 m	R88A-CR1B003N
		5 m	R88A-CR1B005N
		10 m	R88A-CR1B010N
		15 m	R88A-CR1B015N
		20 m	R88A-CR1B020N
		30 m	R88A-CR1B030N
		40 m	R88A-CR1B040N
		50 m	R88A-CR1B050N

Motor Power Cables (Standard Cable)

Applicable Servomotor			Model	
			Without brake wire	With brake wire
200 V	3,000-r/min Servomotors of 100 W, 200 W, 400 W, and 750 W	3 m	R88A-CA1A003S	---
		5 m	R88A-CA1A005S	---
		10 m	R88A-CA1A010S	---
		15 m	R88A-CA1A015S	---
		20 m	R88A-CA1A020S	---
		30 m	R88A-CA1A030S	---
		40 m	R88A-CA1A040S	---
		50 m	R88A-CA1A050S	---
	3,000-r/min Servomotors of 1 kW 2,000-r/min Servomotors of 1 kW	3 m	R88A-CA1B003S	R88A-CA1B003B
		5 m	R88A-CA1B005S	R88A-CA1B005B
		10 m	R88A-CA1B010S	R88A-CA1B010B
		15 m	R88A-CA1B015S	R88A-CA1B015B
		20 m	R88A-CA1B020S	R88A-CA1B020B
		30 m	R88A-CA1B030S	R88A-CA1B030B
		40 m	R88A-CA1B040S	R88A-CA1B040B
		50 m	R88A-CA1B050S	R88A-CA1B050B
	3,000-r/min Servomotors of 1.5 kW 2,000-r/min Servomotors of 1.5 kW	3 m	R88A-CA1C003S	R88A-CA1C003B
		5 m	R88A-CA1C005S	R88A-CA1C005B
		10 m	R88A-CA1C010S	R88A-CA1C010B
		15 m	R88A-CA1C015S	R88A-CA1C015B
		20 m	R88A-CA1C020S	R88A-CA1C020B
		30 m	R88A-CA1C030S	R88A-CA1C030B
		40 m	R88A-CA1C040S	R88A-CA1C040B
		50 m	R88A-CA1C050S	R88A-CA1C050B

Brake Cables (Standard Cable)

Applicable Servomotor		Model	
200 V	3,000-r/min Servomotors of 100 W, 200 W, 400 W, and 750 W	3 m	R88A-CA1A003B
		5 m	R88A-CA1A005B
		10 m	R88A-CA1A010B
		15 m	R88A-CA1A015B
		20 m	R88A-CA1A020B
		30 m	R88A-CA1A030B
		40 m	R88A-CA1A040B
		50 m	R88A-CA1A050B

Encoder Cables (Flexible Cable)

Applicable Servomotor		Model	
200 V	3,000-r/min Servomotors of 100 W, 200 W, 400 W, and 750 W	3 m	R88A-CR1A003CF
		5 m	R88A-CR1A005CF
		10 m	R88A-CR1A010CF
		15 m	R88A-CR1A015CF
		20 m	R88A-CR1A020CF
		30 m	R88A-CR1A030CF
		40 m	R88A-CR1A040CF
		50 m	R88A-CR1A050CF
	3,000-r/min Servomotors of 1kW or more 2,000-r/min Servomotors	3 m	R88A-CR1B003NF
		5 m	R88A-CR1B005NF
		10 m	R88A-CR1B010NF
		15 m	R88A-CR1B015NF
		20 m	R88A-CR1B020NF
		30 m	R88A-CR1B030NF
		40 m	R88A-CR1B040NF
		50 m	R88A-CR1B050NF

Motor Power Cables (Flexible Cable)

Applicable Servomotor		Model		
			Without brake wire	With brake wire
200 V	3,000-r/min Servomotors of 100 W, 200 W, 400 W, and 750 W	3 m	R88A-CA1A003SF	---
		5 m	R88A-CA1A005SF	---
		10 m	R88A-CA1A010SF	---
		15 m	R88A-CA1A015SF	---
		20 m	R88A-CA1A020SF	---
		30 m	R88A-CA1A030SF	---
		40 m	R88A-CA1A040SF	---
		50 m	R88A-CA1A050SF	---
	3,000-r/min Servomotors of 1 kW 2,000-r/min Servomotors of 1 kW	3 m	R88A-CA1B003SF	R88A-CA1B003BF
		5 m	R88A-CA1B005SF	R88A-CA1B005BF
		10 m	R88A-CA1B010SF	R88A-CA1B010BF
		15 m	R88A-CA1B015SF	R88A-CA1B015BF
		20 m	R88A-CA1B020SF	R88A-CA1B020BF
		30 m	R88A-CA1B030SF	R88A-CA1B030BF
		40 m	R88A-CA1B040SF	R88A-CA1B040BF
		50 m	R88A-CA1B050SF	R88A-CA1B050BF
	3,000-r/min Servomotors of 1.5 kW 2,000-r/min Servomotors of 1.5 kW	3 m	R88A-CA1C003SF	R88A-CA1C003BF
		5 m	R88A-CA1C005SF	R88A-CA1C005BF
		10 m	R88A-CA1C010SF	R88A-CA1C010BF
		15 m	R88A-CA1C015SF	R88A-CA1C015BF
		20 m	R88A-CA1C020SF	R88A-CA1C020BF
		30 m	R88A-CA1C030SF	R88A-CA1C030BF
		40 m	R88A-CA1C040SF	R88A-CA1C040BF
		50 m	R88A-CA1C050SF	R88A-CA1C050BF

Brake Cables (Flexible Cable)

Applicable Servomotor		Model	
200 V	3,000-r/min Servomotors of 100 W, 200 W, 400 W, and 750 W	3 m	R88A-CA1A003BF
		5 m	R88A-CA1A005BF
		10 m	R88A-CA1A010BF
		15 m	R88A-CA1A015BF
		20 m	R88A-CA1A020BF
		30 m	R88A-CA1A030BF
		40 m	R88A-CA1A040BF
		50 m	R88A-CA1A050BF

Peripheral Connector

● Servo Drive side connector

Name and application	Model
Main circuit connector (CNA) ^{*1} For R88D-1SN01L-ECT/ -1SN02L-ECT/ -1SN04L-ECT/ -1SN01H-ECT/ -1SN02H-ECT/ -1SN04H-ECT/ -1SN08H-ECT/ -1SN10H-ECT	R88A-CN102P ^{*4}
Main circuit connector A (CNA) ^{*2} For R88D-1SN15H-ECT/ -1SN20H-ECT/ -1SN30H-ECT/ -1SN06F-ECT/ -1SN10F-ECT/ -1SN15F-ECT/ -1SN20F-ECT/ -1SN30F-ECT	R88A-CN103P ^{*4}
Main circuit connector B (CNB) ^{*2} For R88D-1SN15H-ECT/ -1SN20H-ECT/ -1SN30H-ECT/ -1SN06F-ECT/ -1SN10F-ECT/ -1SN15F-ECT/ -1SN20F-ECT/ -1SN30F-ECT	R88A-CN104P ^{*4}
Motor connector (CNC) For R88D-1SN01L-ECT/ -1SN02L-ECT/ -1SN04L-ECT/ -1SN01H-ECT/ -1SN02H-ECT/ -1SN04H-ECT/ -1SN08H-ECT/ -1SN10H-ECT	R88A-CN101A ^{*4}
Motor connector (CNC) R88D-1SN15H-ECT/ -1SN20H-ECT/ -1SN30H-ECT/ -1SN06F-ECT/ -1SN10F-ECT/ -1SN15F-ECT/ -1SN20F-ECT/ -1SN30F-ECT	R88A-CN102A ^{*4}
Control power supply connector (CND) For R88D-1SN15H-ECT/ -1SN20H-ECT/ -1SN30H-ECT/ -1SN06F-ECT/ -1SN10F-ECT/ -1SN15F-ECT/ -1SN20F-ECT/ -1SN30F-ECT	R88A-CN101P ^{*4}
Control I/O connector (CN1) ^{*3}	R88A-CN101C
Encoder connector (CN2)	R88A-CN101R
Brake interlock connector (CN12)	R88A-CN101B

*1. Two short-circuit wires are connected to the connector.

*2. One short-circuit wire is connected to the connector.

*3. Four short-circuit wires are connected to the connector.

*4. One opener is included.

● **Servomotor side connector**

Name and application			Model
Encoder connector	200 V	For 3,000 r/min (100 to 750 W)	R88A-CNK02R
	200 V	For 3,000 r/min (1 to 1.5 kW) For 2,000 r/min	R88A-CN104R
Power connector (for 750 W max.)			R88A-CN111A
Brake connector (for 750 W max.)			R88A-CN111B

2-4 External and Mounting Dimensions

This section provides the external dimensions and mounting dimensions of Servo Drives, Servomotors and peripheral devices.

2-4-1 Servomotor Dimensions

Servomotors are grouped by rated rotation speed, and described in order of increasing rated output.

3,000-r/min Servomotors (200 V)

● 100 W (without Brake)

R88M-1M10030H-S2

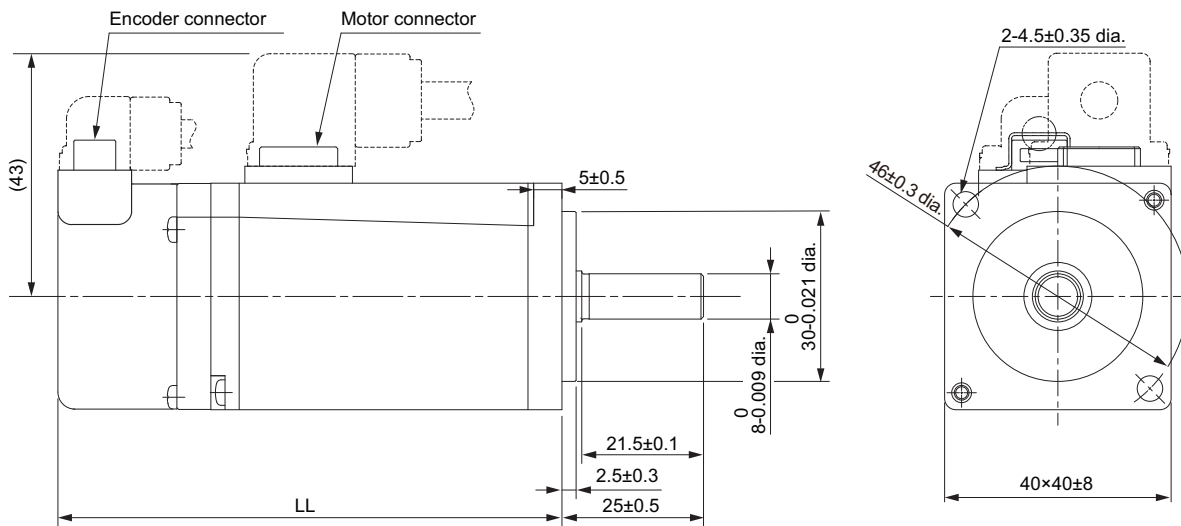

Model	Dimensions [mm]
	LL
R88M-1M10030H-S2	89±1

Note The standard shaft type is with a key and tap.

Shaft-end with key and tap

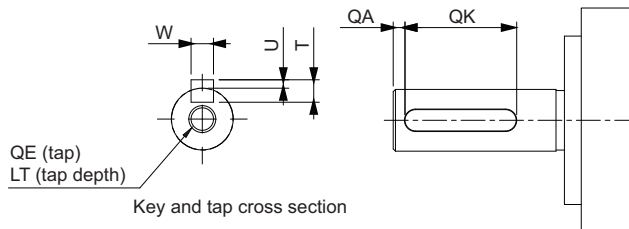

Model	Dimensions [mm]						
	QA	QK	W	T	U	QE	LT
R88M-1M10030H-S2	2	12	3 ₀ -0.025	3	1.2 ₀ -0.2	M3	8

● 100 W (with Brake)

R88M-1M10030H-BS2

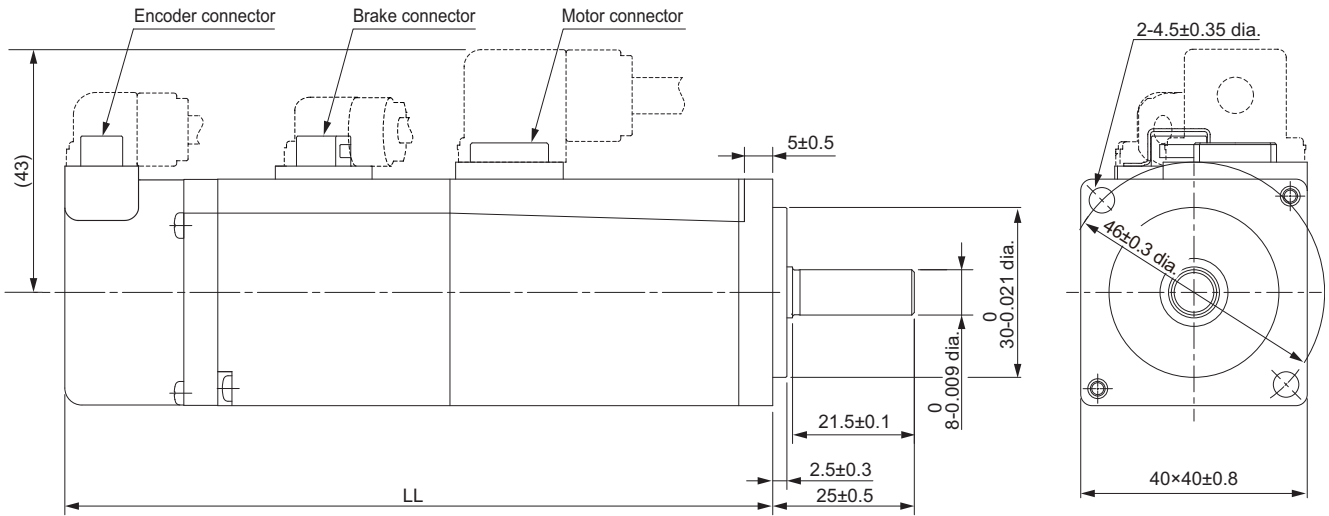

Model	Dimensions [mm]
	LL
R88M-1M10030H-BS2	125±1

Note The standard shaft type is with a key and tap.

Shaft-end with key and tap

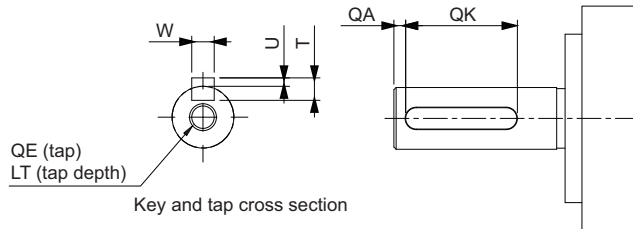

Model	Dimensions [mm]						
	QA	QK	W	T	U	QE	LT
R88M-1M10030H-BS2	2	12	0 3 -0.025	3	1.2 0 -0.2	M3	8

● 200 W/400 W (without Brake)

R88M-1M20030H-S2

R88M-1M40030H-S2

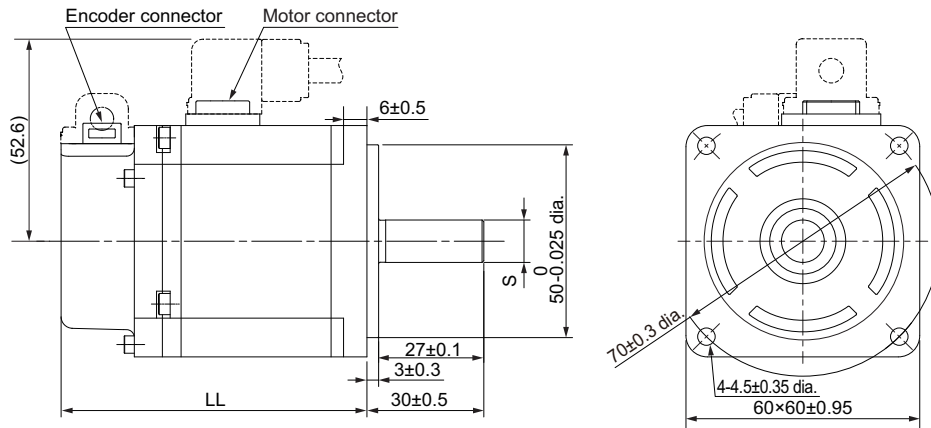

Model	Dimensions [mm]	
	S	LL
R88M-1M20030H-S2	11 0 -0.011 dia.	78.5±1
R88M-1M40030H-S2	14 0 -0.011 dia.	104.5±1

Note The standard shaft type is with a key and tap.

Shaft-end with key and tap

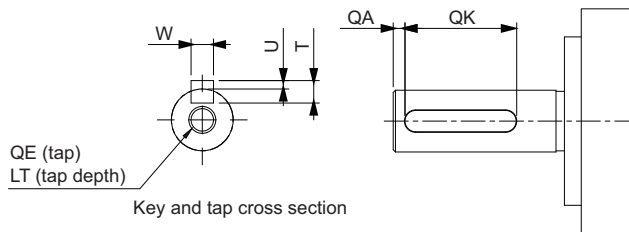

Model	Dimensions [mm]						
	QA	QK	W	T	U	QE	LT
R88M-1M20030H-S2	2	20	4 0 -0.03	4	1.5 0 -0.2	M4	10
R88M-1M40030H-S2	2	20	5 0 -0.03	5	2 0 -0.2	M5	12

● 200 W/400 W (with Brake)

R88M-1M20030H-BS2

R88M-1M40030H-BS2

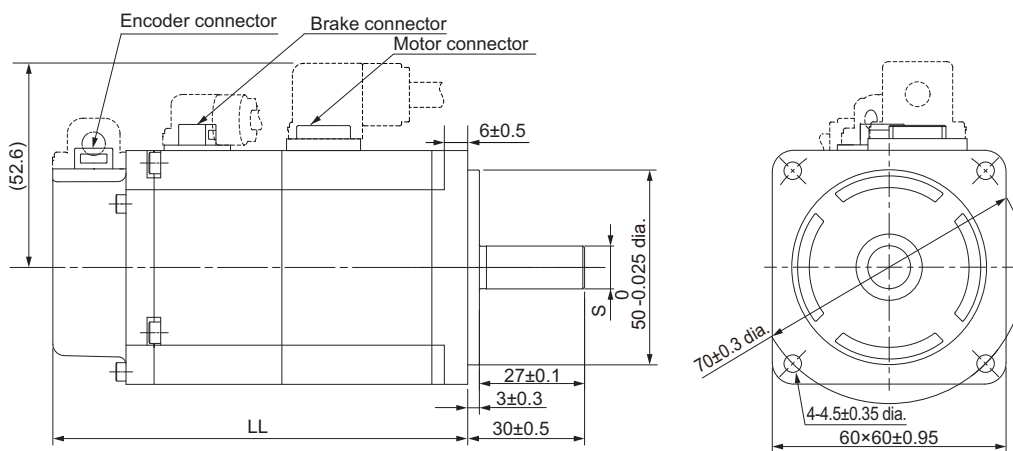

Model	Dimensions [mm]	
	S	LL
R88M-1M20030H-BS2	11 0 -0.011 dia.	106.5±1
R88M-1M40030H-BS2	14 0 -0.011 dia.	132.5±1

Note The standard shaft type is with a key and tap.

Shaft-end with key and tap

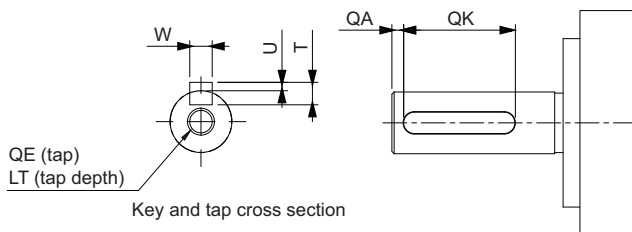

Model	Dimensions [mm]						
	QA	QK	W	T	U	QE	LT
R88M-1M20030H-BS2	2	20	4 0 -0.03	4	1.5 0 -0.2	M4	10
R88M-1M40030H-BS2	2	20	5 0 -0.03	5	2 0 -0.2	M5	12

● 750 W (without Brake)

R88M-1M75030H-S2

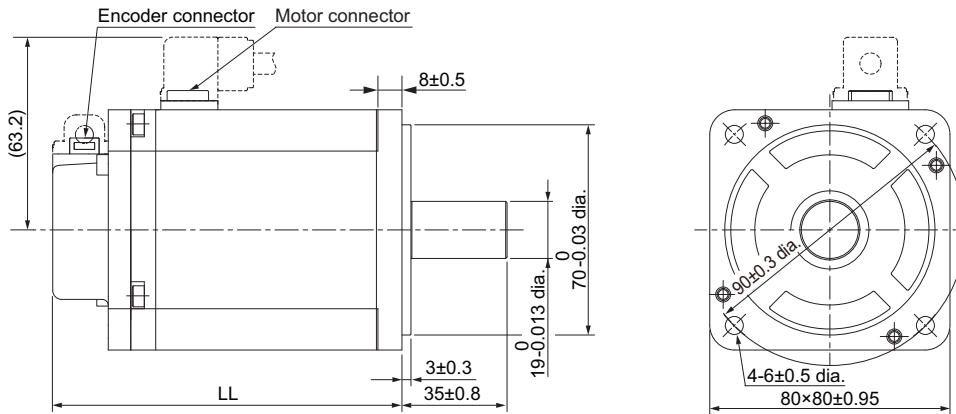

Model	Dimensions [mm]
	LL
R88M-1M75030H-S2	116.3±1

Note The standard shaft type is with a key and tap.

Shaft-end with key and tap

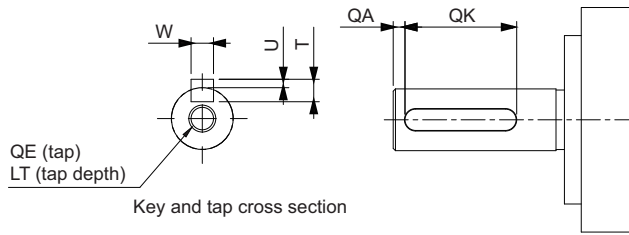

Model	Dimensions [mm]						
	QA	QK	W	T	U	QE	LT
R88M-1M75030H-S2	3	24	6 ⁰ _{-0.03}	6	2.5 ⁰ _{-0.2}	M5	12

● 750 W (with Brake)

R88M-1M75030H-BS2

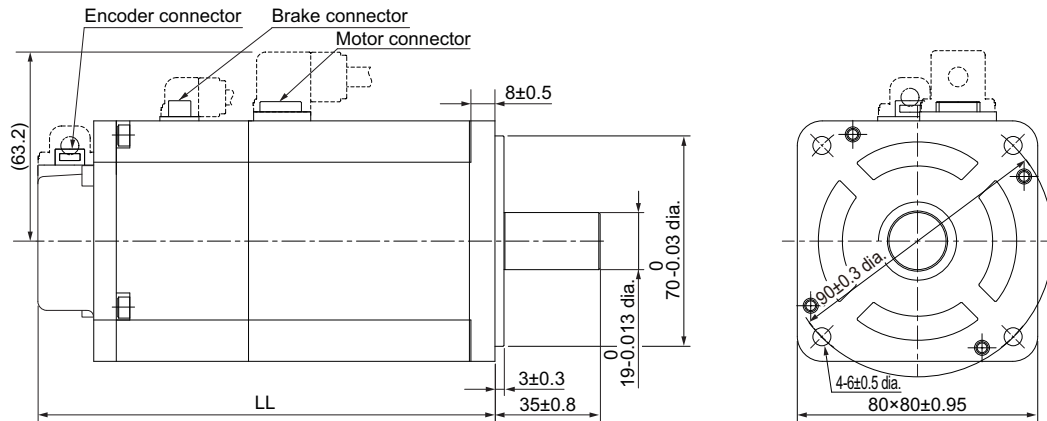

Model	Dimensions [mm]
	LL
R88M-1M75030H-BS2	152±1

Note The standard shaft type is with a key and tap.

Shaft-end with key and tap

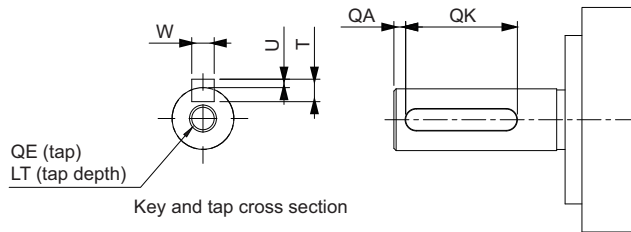

Model	Dimensions [mm]						
	QA	QK	W	T	U	QE	LT
R88M-1M75030H-BS2	3	24	6 0 -0.03	6	2.5 0 -0.2	M5	12

● 1 kW/1.5 kW (without Brake)

R88M-1L1K030H-S2

R88M-1L1K530H-S2

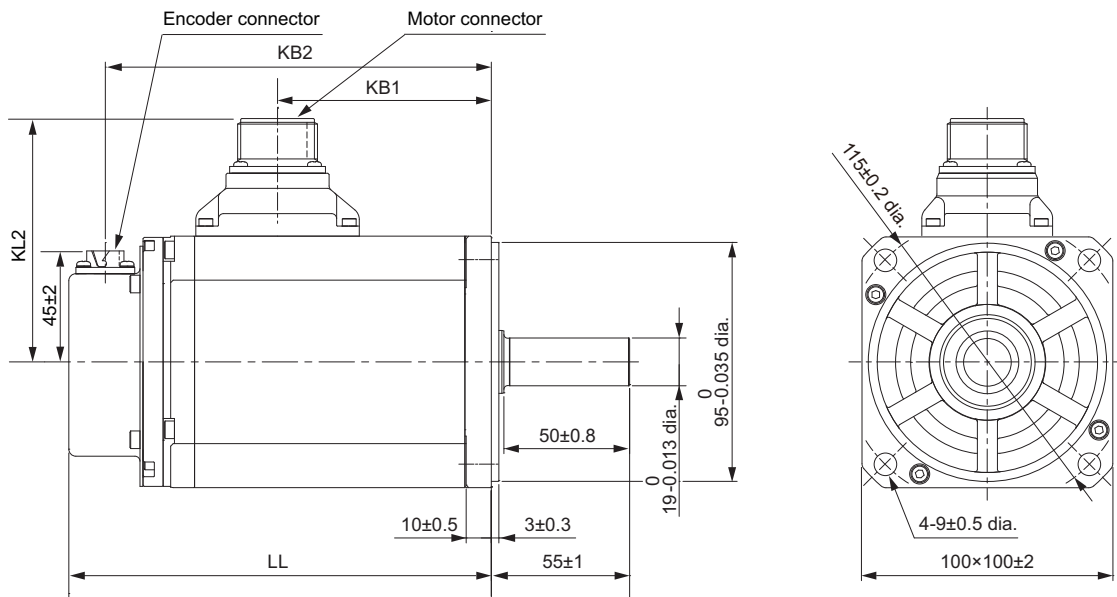

Model	Dimensions [mm]			
	LL	KB1	KB2	KL2
R88M-1L1K030H-S2	168±2	85±1	153±2	97±2
R88M-1L1K530H-S2	168±2	85±1	153±2	97±2

Note The standard shaft type is with a key and tap.

Shaft-end with key and tap

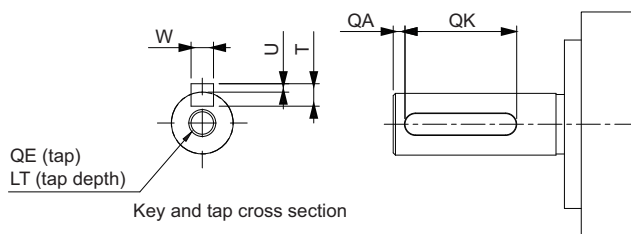

Model	Dimensions [mm]						
	QA	QK	W	T	U	QE	LT
R88M-1L1K030H-S2	3	42	6 ⁰ _{-0.03}	6	2.5 ⁰ _{-0.2}	M5	12
R88M-1L1K530H-S2	3	42	6 ⁰ _{-0.03}	6	2.5 ⁰ _{-0.2}	M5	12

● 1 kW/1.5 kW (with Brake)

R88M-1L1K030H-BS2

R88M-1L1K530H-BS2

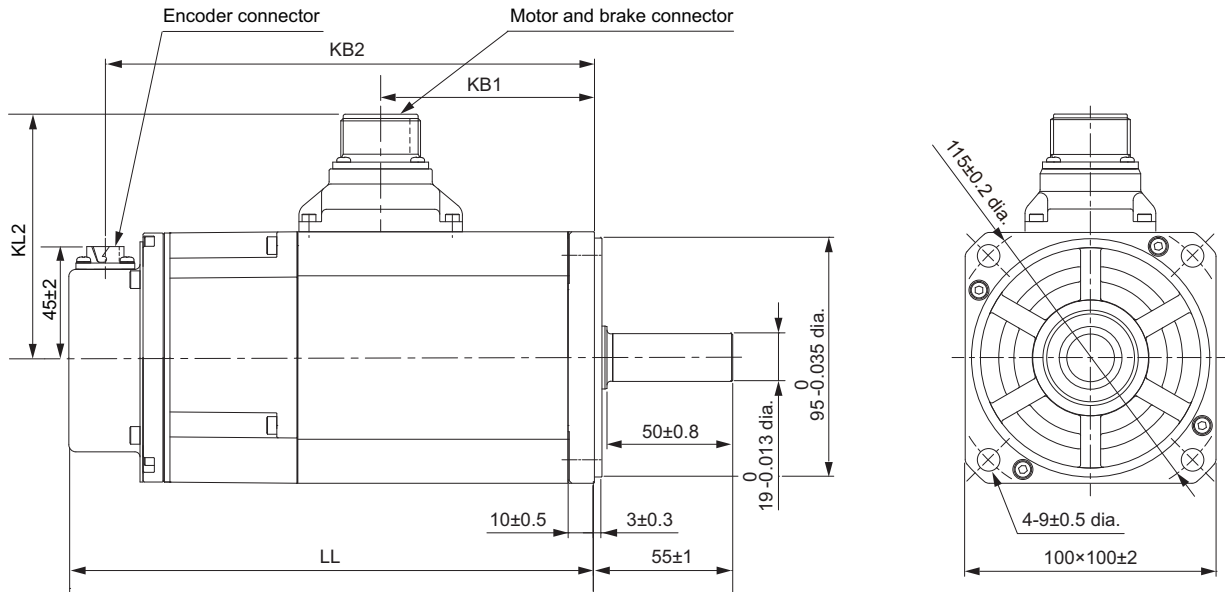

Model	Dimensions [mm]			
	LL	KB1	KB2	KL2
R88M-1L1K030H-BS2	209±3	85±1	194±2	97±2
R88M-1L1K530H-BS2	209±3	85±1	194±2	97±2

Note The standard shaft type is with a key and tap.

Shaft-end with key and tap

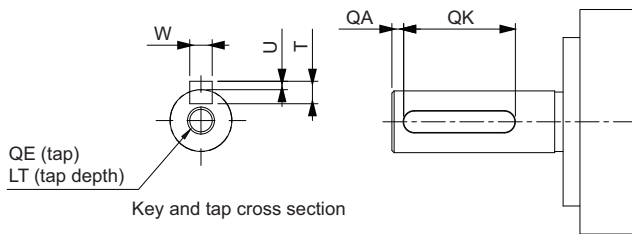

Model	Dimensions [mm]						
	QA	QK	W	T	U	QE	LT
R88M-1L1K030H-BS2	3	42	6 ⁰ _{-0.03}	6	2.5 ⁰ _{-0.2}	M5	12
R88M-1L1K530H-BS2	3	42	6 ⁰ _{-0.03}	6	2.5 ⁰ _{-0.2}	M5	12

2,000-r/min Servomotors (200 V)

● 1 kW/1.5 kW (without Brake)

R88M-1M1K020H-S2

R88M-1M1K520H-S2

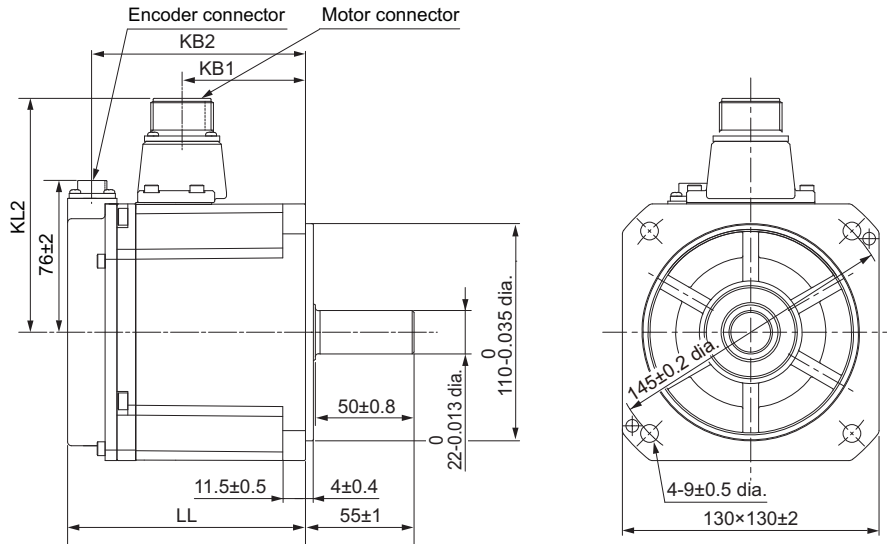

Model	Dimensions [mm]			
	LL	KB1	KB2	KL2
R88M-1M1K020H-S2	120.5±2	63±1	109±2	118±2
R88M-1M1K520H-S2	138±2	79±1	125±2	118±2

Note The standard shaft type is with a key and tap.

Shaft-end with key and tap

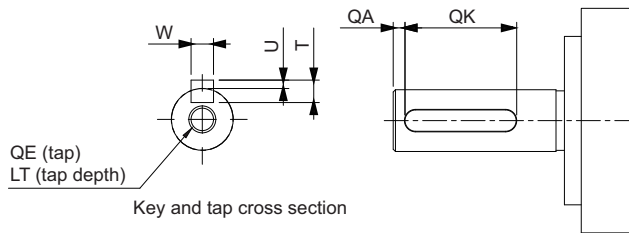

Model	Dimensions [mm]						
	QA	QK	W	T	U	QE	LT
R88M-1M1K020H-S2	3	42	8 ⁰ _{-0.036}	7	3 ⁰ _{-0.4}	M5	12
R88M-1M1K520H-S2	3	42	8 ⁰ _{-0.036}	7	3 ⁰ _{-0.4}	M5	12

● 1 kW/1.5 kW (with Brake)

R88M-1M1K020H-BS2

R88M-1M1K520H-BS2

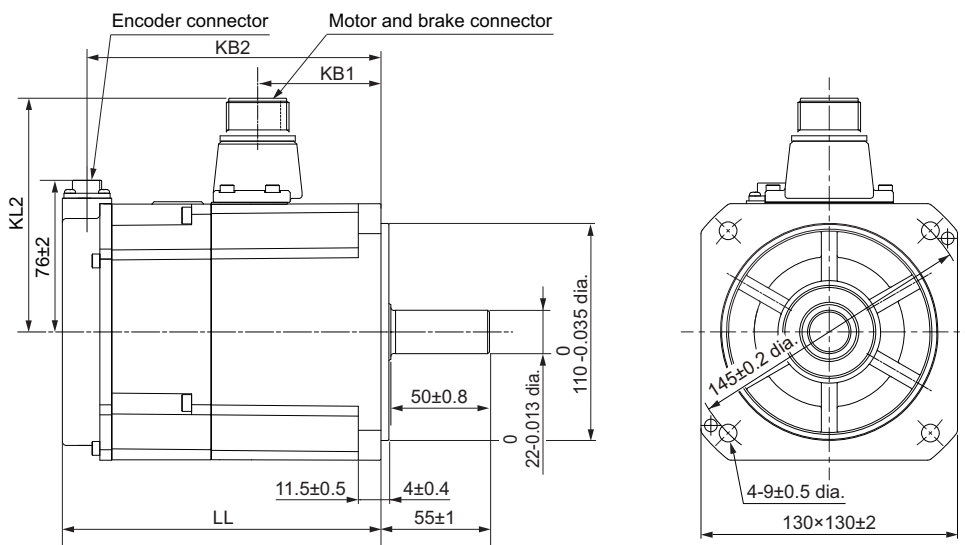

Model	Dimensions [mm]			
	LL	KB1	KB2	KL2
R88M-1M1K020H-BS2	162±2	63±1	149±2	118±2
R88M-1M1K520H-BS2	179±2	79±1	166±2	118±2

Note The standard shaft type is with a key and tap.

Shaft-end with key and tap

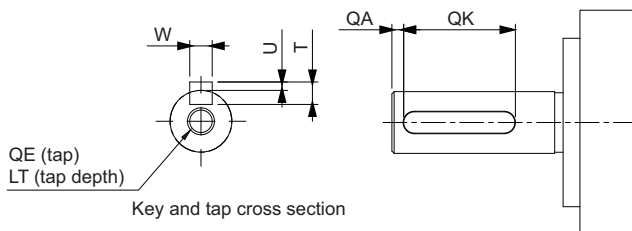

Model	Dimensions [mm]						
	QA	QK	W	T	U	QE	LT
R88M-1M1K020H-BS2	3	42	8 ⁰ _{-0.036}	7	3 ⁰ _{-0.4}	M5	12
R88M-1M1K520H-BS2	3	42	8 ⁰ _{-0.036}	7	3 ⁰ _{-0.4}	M5	12

3

Specifications

This section provides the general specifications, characteristics, encoder specifications of the Servomotors and other peripheral devices.

For the general specifications, connector specifications and I/O circuits of the Servo Drives, refer to the *AC Servomotors/Servo Drives 1S-series with Built-in EtherCAT® Communications User's Manual (I586)*.

3-1	Servo Drive Specifications	3-2
3-1-1	Characteristics	3-2
3-1-2	Main Circuit and Motor Connections	3-4
3-1-3	Encoder Connector (CN2) Specifications	3-8
3-1-4	Overload Characteristics (Electronic Thermal Function)	3-8
3-2	Servomotor Specifications	3-10
3-2-1	General Specifications	3-10
3-2-2	Encoder Specifications	3-11
3-2-3	Characteristics	3-12
3-3	Cable and Connector Specifications	3-17
3-3-1	Encoder Cable Specifications	3-17
3-3-2	Motor Power Cable Specifications	3-22
3-3-3	Resistance to Bending of Flexible Cable	3-34
3-3-4	Connector Specifications	3-36

3-1 Servo Drive Specifications

Select a Servo Drive that matches the Servomotor to be used. Refer to 2-3-2 *Servo Drive and Servomotor Combination Tables* on page 2-6.

3-1-1 Characteristics

The characteristics of the Servo Drives are shown below.

200-VAC Input Models

Servo Drive model (R88D-)			1SN01H-ECT	1SN02H-ECT	1SN04H-ECT	1SN08H-ECT
Item			100 W	200 W	400 W	750 W
Input	Main circuit	Power supply voltage	Single-phase and 3-phase 200 to 240 VAC (170 to 252 V) ^{*1}			
		Frequency	50/60 Hz (47.5 to 63 Hz) ^{*1}			
	Control circuit	Power supply voltage	24 VDC (21.6 to 26.4 V)			
		Current consumption ^{*2}	600 mA			
	Rated current [A (rms)] (Main circuit power supply voltage: 240 VAC)	Single-phase	1.8	2.7	4.6	7.3
		3-phase	1.0	1.5	2.7	4.0
Output	Rated current [A (rms)]		0.8	1.5	2.5	4.6
	Maximum current [A (rms)]		3.1	5.6	9.1	16.9
Maximum power loss of Servo Drive at power conversion			10% (Load condition: rated output)			
Applicable Servomotor rated output [W]			100	200	400	750
3,000-r/min Servomotor (R88M-)	23-bit INC		1M10030H	1M20030H	1M40030H	1M75030H
2,000-r/min Servomotor (R88M-)	23-bit INC		---	---	---	---
Hold time at momentary power interruption (Main circuit power supply voltage: 200 VAC)			10 ms (Load condition: rated output) ^{*3}			
Weight [kg]			1.2	1.2	1.5	2.0

Servo Drive model (R88D-)			1SN10H-ECT	1SN15H-ECT
Item			1 kW	1.5 kW
Input	Main circuit	Power supply voltage	3-phase 200 to 240 VAC (170 to 252 V) ^{*1}	Single-phase and 3-phase 200 to 240 VAC (170 to 252 V) ^{*1}
		Frequency	50/60 Hz (47.5 to 63 Hz) ^{*1}	
	Control circuit	Power supply voltage	24 VDC (21.6 to 26.4 V)	
		Current consumption ^{*2}	600 mA	900 mA
	Rated current [A (rms)] (Main circuit power supply voltage: 240 VAC)	Single-phase	---	15.7
3-phase		5.8	9.0	
Output	Rated current [A (rms)]		7.7	9.7
	Maximum current [A (rms)]		16.9	28.4
Maximum power loss at power conversion			10% (Load condition: rated output)	
Applicable Servomotor rated output [W]			1,000	1,500
3,000-r/min Servomotor (R88M-)		23-bit INC	1L1K030H	1L1K530H
2,000-r/min Servomotor (R88M-)		23-bit INC	1M1K020H	1M1K520H
Hold time at momentary power interruption (Main circuit power supply voltage: 200 VAC)			10 ms (Load condition: rated output) ^{*3}	
Weight [kg]			2.0	3.4

*1. The values outside parentheses indicate the rated value, and the values inside parentheses indicate the range of acceptable variation.

*2. Select a DC power supply in consideration of the current values that are specified in the current consumption.

The rated current value that is printed on the product nameplate is a condition to apply the 1S-series product for the UL/Low Voltage Directive.

Therefore, you do not need to consider it when you select a DC power supply for each model.

*3. The control power supply is not specified here as long as a DC power supply that meets the following conditions is used.

Reinforced insulation or double insulation, and the output hold time of 10 ms or more

3-1-2 Main Circuit and Motor Connections

When you wire the main circuit, use proper wire sizes, grounding systems, and noise resistance.

R88D-1SN01H-ECT/-1SN02H-ECT/-1SN04H-ECT/-1SN08H-ECT /-1SN10H-ECT

● Main Circuit Connector (CNA) Specifications

Pin No.	Symbol	Name	Specifications
1	L1	Main circuit power supply input	R88D-1SN□H-ECT Single-phase*1 200 to 240 VAC (170 to 252 V) 50/60 Hz (47.5 to 63 Hz) R88D-1SN□H-ECT 3-phase 200 to 240 VAC (170 to 252 V) 50/60 Hz (47.5 to 63 Hz)
2	L2		
3	L3		
4	B3	External Regeneration Resistor connection terminals	When the Internal Regeneration Resistor is used: • Open between B1 and B2. • Short-circuit B2 and B3. When the External Regeneration Resistor is used: • Connect the External Regeneration Resistor between B1 and B2. • Open between B2 and B3.
5	B2		
6	P/B1		
7	N1	DC reactor connection terminals	When the DC reactor is not used: • Short-circuit N1 and N2. When the DC reactor is used: • Connect the DC reactor between N1 and N2.
8	N2		
9	N3		
10	24V	Control circuit power supply input	24 VDC (21.6 to 26.4 V) Measured current value: 600 mA
11	∅		

*1. For single-phase, connect between any two phases out of the following: L1, L2, and L3.

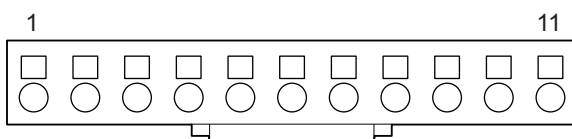

● Motor Connector (CNC) Specifications

Pin No.	Symbol	Name	Specifications
1	U	Motor connection terminals	Phase U
2	V		Phase V
3	W		Phase W

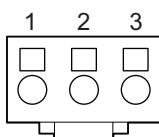

R88D-1SN15H-ECT

● Main Circuit Connector A (CNA) Specifications

Symbol	Name	Specifications
B1	External Regeneration Resistor connection terminals	When the Internal Regeneration Resistor is used: <ul style="list-style-type: none"> • Open between B1 and B2. • Short-circuit B2 and B3. When the External Regeneration Resistor is used: <ul style="list-style-type: none"> • Connect the External Regeneration Resistor between B1 and B2. • Open between B2 and B3.
B2		
B3		
L3	Main circuit power supply input	R88D-1SN15H-ECT Single-phase *1 200 to 240 VAC (170 to 252 V) 50/60 Hz (47.5 to 63 Hz) R88D-1SN15H-ECT/-1SN20H-ECT/-1SN30H-ECT 3-phase 200 to 240 VAC (170 to 252 V) 50/60 Hz (47.5 to 63 Hz)
L2		
L1		

*1. For single-phase, connect between any two phases out of the following: L1, L2, and L3.

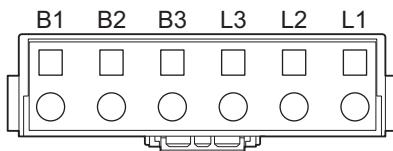

● Main Circuit Connector B (CNB) Specifications

Symbol	Name	Specifications
N3	DC reactor connection terminals	When the DC reactor is not used:
N2		
N1		When the DC reactor is used:
P		

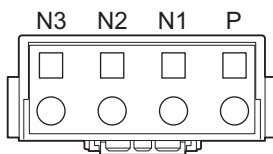

● Control Circuit Connector (CND) Specifications

Pin No.	Symbol	Name	Specifications
1	+24V	Control circuit power supply input	24 VDC (21.6 to 26.4 V)
2	0 V		Measured current value: 900 mA
3	---	---	Do not connect.

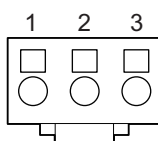

● Motor Connector (CNC) Specifications

Symbol	Name	Specifications	
W	Motor connection terminals	Phase W	These are output terminals to the Servomotor. Be sure to wire them correctly.
V		Phase V	
U		Phase U	
FG		FG	

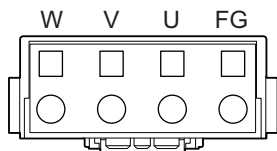



Terminal Block Wire Sizes

The following tables show the rated current that flows to the terminal block on the Servo Drive and the applicable wire sizes. Use the wire with the rated voltage of 600 V or higher for the main circuit.

The wire size is determined for when the heat-resistant polyvinyl chloride insulated wire (HIV) is used at the ambient temperature of 50°C.

● Wire Sizes for 200-VAC Input Model: R88D-1SN□H-ECT

Item		Unit	Model (R88D-1SN)				
			01H-ECT	02H-ECT	04H-ECT	08H-ECT	10H-ECT
Power supply capacity		kVA	0.6	0.6	1.0	1.4	2.0
Main circuit power supply input (L1, L2, and L3) *1	Rated current	A(rms)	1.8/1.0*2	2.7/1.5*2	4.6/2.7*2	7.3/4.0*2	5.8
	Wire size	---	AWG 22 to 14, 0.32 to 2.0 mm ²	AWG 20 to 14, 0.5 to 2.0 mm ²	AWG 18 to 14, 0.75 to 2.0 mm ²	AWG16 to 14, 1.3 to 2.0 mm ²	
Control circuit power supply input (24 V, Ø)	Wire size	---	AWG 20 to 16, 0.5 to 1.5 mm ²				
Motor connection terminals (U, V, and W)*3*4	Rated current	A(rms)	0.8	1.5	2.5	4.6	7.7
	Wire size	---	AWG 22 to 14, 0.32 to 2.0 mm ²		AWG 20 to 14, 0.5 to 2.0 mm ²	AWG 18 to 14, 0.75 to 2.0 mm ²	AWG16 to 14, 1.3 to 2.0 mm ²
Protective earth 	Wire size	---	AWG 12, 2.5 mm ²				
	Screw size	---	M4				
	Tightening torque	N·m	1.2				

Item	Unit	Model (R88D-1SN)	
		15H-ECT	
Power supply capacity	kVA	2.5	
Main circuit power supply input (L1, L2, and L3) *1	Rated current	A	15.7/ 9.0*2
	Wire size	---	AWG 12 to 8, 3.3 to 8.4 mm ²
Control circuit power supply input (+24 V and 0 V)	Wire size	---	AWG 20 to 16, 0.5 to 1.5 mm ²
Motor connection terminals (U, V, and W) *3*4	Rated current	A	9.7
	Wire size	---	AWG 14 to 8, 2.0 to 8.4 mm ²
Protective earth 	Wire size	---	AWG 12, 2.5 mm ²
	Screw size	---	M4
	Tightening torque	N·m	1.2

*1. For single-phase, connect between any two phases out of the following: L1, L2, and L3.

*2. The first value is for single-phase input power and the second value is for 3-phase input power.

*3. Connect OMRON Power Cables to the motor connection terminals.

*4. Use the wire with the same current capacity for the wiring of the motor connection terminals and for that of B1 and B2.

Wire Sizes and Allowable Current (Reference)

The following table shows the allowable currents for each wire size.

Select wires carefully so that the specified allowable currents are not exceeded.

● 600-V Heat-resistant Vinyl Wire (HIV)

AWG size	Nominal cross-sectional area [mm ²]	Configuration [wires/mm ²]	Conductive resistance [Ω/km]	Allowable current [A] for ambient temperature		
				30°C	40°C	50°C
20	0.5	19/0.18	39.5	6.6	5.6	4.5
---	0.75	30/0.18	26.0	8.8	7.0	5.5
18	0.9	37/0.18	24.4	9.0	7.7	6.0
16	1.25	50/0.18	15.6	12.0	11.0	8.5
14	2.0	7/0.6	9.53	23	20	16
12	3.5	7/0.8	5.41	33	29	24
10	5.5	7/1.0	3.47	43	38	31
8	8.0	7/1.2	2.41	55	49	40
6	14.0	7/1.6	1.35	79	70	57
4	22.0	7/2.0	0.85	99	88	70

3-1-3 Encoder Connector (CN2) Specifications

The specifications of the encoder connectors are shown below.

Pin No.	Symbol	Name
1	E5V	Encoder power supply voltage
2	E0V	Encoder power supply GND
3	Not used.	NC
4	Not used.	NC
5	PS+	Encoder + phase S I/O
6	PS-	Encoder - phase S I/O
Shell	FG	Frame ground

● Connectors for CN2 (6 Pins)

Name	Model	Manufacturer	OMRON model
Receptacle	3E206-0100KV	3M	R88A-CN101R
Shell kit	3E306-3200-008	3M	

3-1-4 Overload Characteristics (Electronic Thermal Function)

The overload protection function (electronic thermal) is built into the Servo Drive to protect the Servo Drive and Servomotor from overloading.

If an overload occurs, first eliminate the cause of the overload and then wait for the Servomotor temperature to drop before you turn ON the power again.

If the error reset is repeated at short intervals, the Servomotor windings may burn out.

Overload Characteristics Graphs

The following graphs show the electronic thermal operation time after continuous operation with 100% load (hot start).

The electronic thermal operation time after a continuous 0% load state (cold start) is longer than that for a hot start.

In cases where models with an oil seal or with a brake have different characteristics, each of their characteristics is described.

The characteristics are the same as those of models with no option unless otherwise specified.

● 200-VAC Servomotors

• 100 W

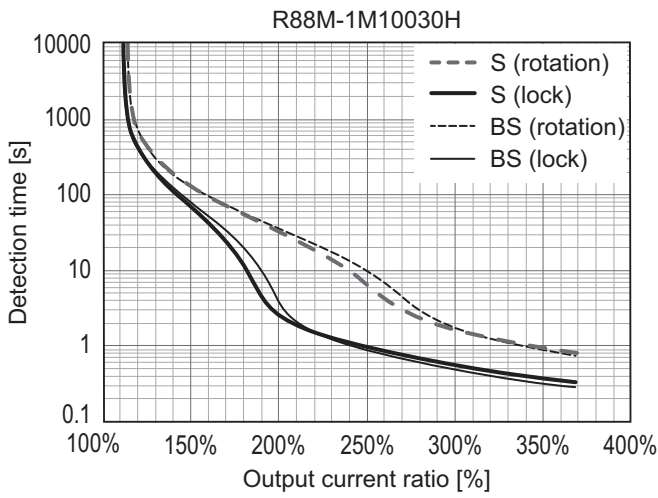

• 200 W

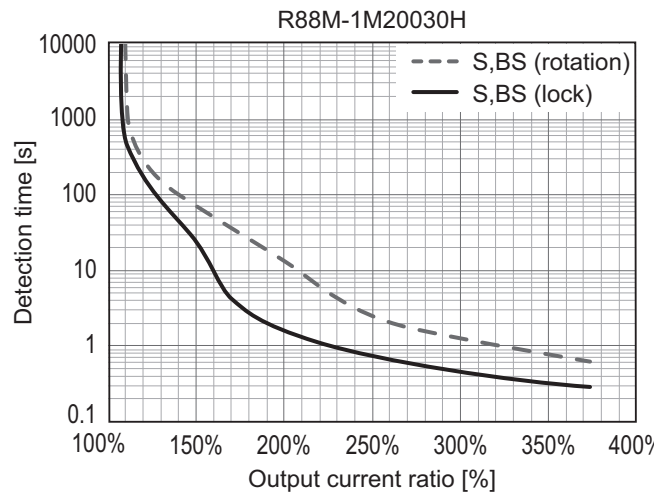

• 400 W

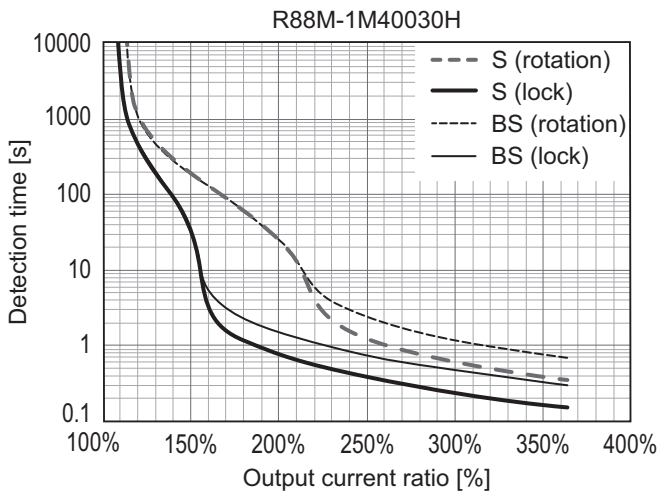

• 750 W

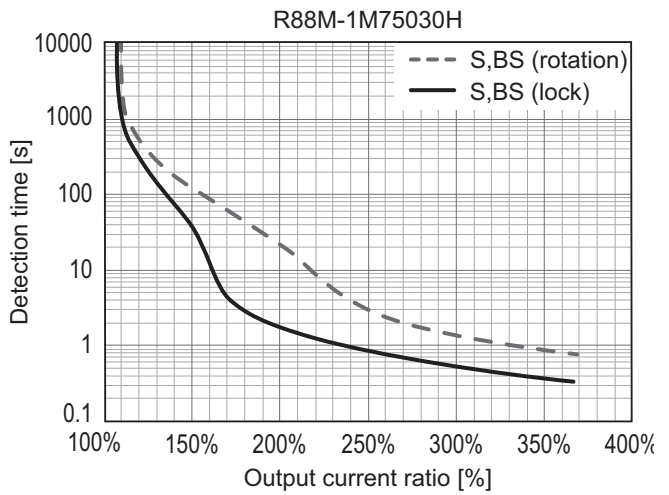

• 1 kW

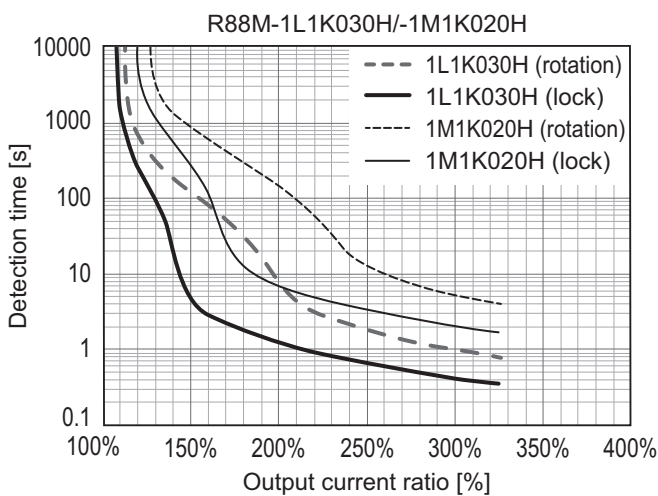

• 1.5 kW

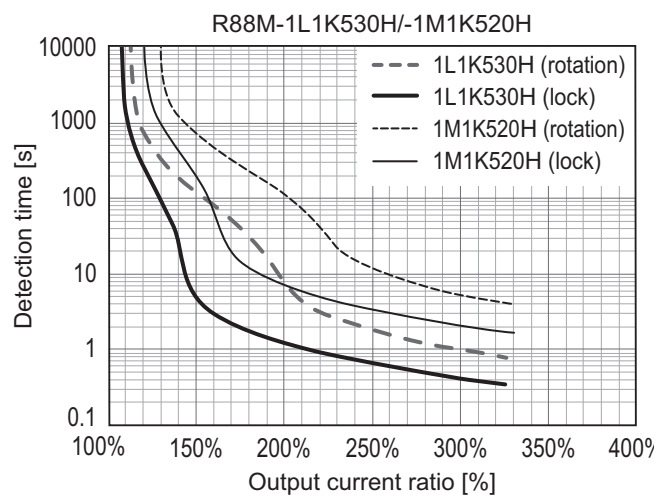

3-2 Servomotor Specifications

The following 1S-Series Incremental Encoder Type Servomotors are available.

- 3,000-r/min Servomotors
- 2,000-r/min Servomotors

There are various options available, such as models with brakes, or different shaft types.

Select a Servomotor based on the mechanical system's load conditions and the installation environment.

3-2-1 General Specifications

Item			Specifications
Operating ambient temperature and humidity			0 to 40°C 20% to 90% (with no condensation)
Storage ambient temperature and humidity			-20 to 65°C 20% to 90% (with no condensation)
Operating and storage atmosphere			No corrosive gases
Vibration resistance*1			Acceleration of 49 m/s ² 24.5 m/s ² max. in X, Y, and Z directions when the motor is stopped
Impact resistance			Acceleration of 98 m/s ² max. 3 times each in X, Y, and Z directions
Insulation resistance			Between power terminals and FG terminals: 10 MΩ min. (at 500 VDC Megger)
Dielectric strength			Between power terminals and FG terminals: 1,500 VAC for 1 min (voltage 100 V, 200 V) Between power terminals and FG terminals: 1,800 VAC for 1 min (voltage 400 V) Between brake terminal and FG terminals: 1,000 VAC for 1 min
Insulation class			Class F
Protective structure			IP67 (except for the through-shaft part and connector pins) IP20 if you use a 30-meter or longer encoder cable.
International standard	EU Directives	Low Voltage Directive	EN 60034-1/-5
	UL standards		UL 1004-1/-6
	CSA standards		CSA C22.2 No.100 (with cUL mark)

*1. The amplitude may be increased by machine resonance. As a guideline, 80% of the specified value must not be exceeded.

Note 1. Do not use the cable when it is laying in oil or water.

2. Do not expose the cable outlet or connections to stress due to bending or its own weight.

3-2-2 Encoder Specifications

The encoder specifications are shown below.

Item	Specifications
Encoder system	Optical incremental encoder
Resolution per rotation	23 bits
Power supply voltage	5 VDC \pm 10%
Current consumption	230 mA max.
Output signal	Serial communications
Output interface	RS485 compliant

3-2-3 Characteristics

3,000-r/min Servomotors

Item		Model (R88M-) Unit	200 VAC			
			1M10030H	1M20030H	1M40030H	1M75030H
Rated output*1*2		W	100	200	400	750
Rated torque*1*2		N·m	0.318	0.637	1.27	2.39
Rated rotation speed*1*2		r/min	3,000			
Maximum rotation speed		r/min	6,000			
Momentary maximum torque*1		N·m	1.11	2.2	4.5	8.4
Rated current**1*2		A (rms)	0.84	1.5	2.5	4.6
Momentary maximum current*1		A (rms)	3.10	5.6	9.1	16.9
Rotor inertia	Without brake	× 10 ⁻⁴ kg·m ²	0.0890	0.2232	0.4452	1.8242
	With brake	× 10 ⁻⁴ kg·m ²	0.0968	0.2832	0.5052	2.0742
Applicable load inertia		× 10 ⁻⁴ kg·m ²	1.62	4.80	8.40	19.4
Torque constant*1		N·m/ A (rms)	0.42	0.48	0.56	0.59
Power rate*1*3		kW/s	11.9	18.5	36.6	31.4
Mechanical time constant*3		ms	1.2	0.78	0.56	0.66
Electrical time constant		ms	0.83	2.4	2.6	3.3
Allowable radial load*4		N	68	245	245	490
Allowable thrust load*4		N	58	88	88	196
Weight	Without brake	kg	0.52	1.0	1.4	2.9
	With brake	kg	0.77	1.3	1.9	3.9
Radiator plate dimensions (material)		mm	250 × 250 × t6 (aluminum)			
Brake specifications	Excitation voltage*5	V	24 DC ±10%			
	Current consumption (at 20°C)	A	0.27	0.32	0.32	0.37
	Static friction torque	N·m	0.32 min.	1.37 min.	1.37 min.	2.55 min.
	Attraction time	ms	25 max.	30 max.	30 max.	40 max.
	Release time*6	ms	15 max.	20 max.	20 max.	35 max.
	Backlash	°	1.2 max.	1.2 max.	1.2 max.	1.0 max.
	Allowable braking work	J	9	60	60	250
	Allowable total work	J	9,000	60,000	60,000	250,000
	Allowable angular acceleration	rad/s ²	10,000 max.			
	Brake lifetime (acceleration/deceleration)	---	10 million times min.			
Insulation class		---	Class F			

Item		Model (R88M-) Unit	200 VAC	
			1L1K030H	1L1K530H
Rated output*1*2		W	1,000	1,500
Rated torque*1*2		N·m	3.18	4.77
Rated rotation speed*1*2		r/min	3,000	
Maximum rotation speed		r/min	5,000	
Momentary maximum torque*1		N·m	9.55	14.3
Rated current*1*2		A (rms)	5.2	8.8
Momentary maximum current*1		A (rms)	16.9	28.4
Rotor inertia	Without brake	$\times 10^{-4}$ kg·m ²	2.1042	2.1042
	With brake	$\times 10^{-4}$ kg·m ²	2.5542	2.5542
Applicable load inertia		$\times 10^{-4}$ kg·m ²	35.3	47.6
Torque constant*1		N·m/ A (rms)	0.67	0.58
Power rate*1*3		kW/s	48	108
Mechanical time constant*3		ms	0.58	0.58
Electrical time constant		ms	5.9	6.1
Allowable radial load*4		N	490	
Allowable thrust load*4		N	196	
Weight	Without brake	kg	5.7	5.7
	With brake	kg	7.4	7.4
Radiator plate dimensions (material)		mm	400 × 400 × t20 (aluminum)	
Brake specifications	Excitation voltage*5	V	24 VDC±10%	
	Current consumption (at 20°C)	A	0.70	0.70
	Static friction torque	N·m	9.3 min.	9.3 min.
	Attraction time	ms	100 max.	100 max.
	Release time*6	ms	30 max.	30 max.
	Backlash	°	1.0 max.	1.0 max.
	Allowable braking work	J	500	500
	Allowable total work	J	900,000	900,000
	Allowable angular acceleration	rad/s ²	10,000 max.	
	Brake lifetime (acceleration/deceleration)	---	10 million times min.	
Insulation class		---	Class F	

*1. This is a typical value for when the Servomotor is used at a normal temperature (20°C, 65%) in combination with a Servo Drive.

*2. The rated values are the values with which continuous operation is possible at an ambient temperature of 40°C when the Servomotor is horizontally installed on a specified radiator plate.

*3. This value is for models without options.

- *4. The allowable radial and thrust loads are the values determined for a limit of 20,000 hours at normal operating temperatures.

The allowable radial loads are applied as shown in the following diagram.

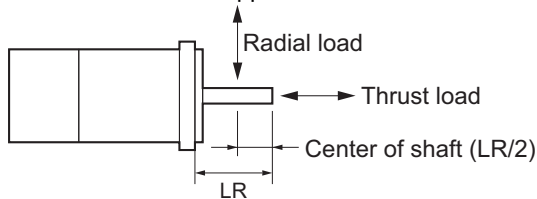

- *5. This is a non-excitation brake. It is released when excitation voltage is applied.
- *6. This value is a reference value.

● Torque-Rotation Speed Characteristics for 3,000-r/min Servomotors (200 VAC)

The following graphs show the characteristics with a 3-m standard cable and a 3-phase 200-VAC or single-phase 220-VAC input.

• R88M-1M10030H

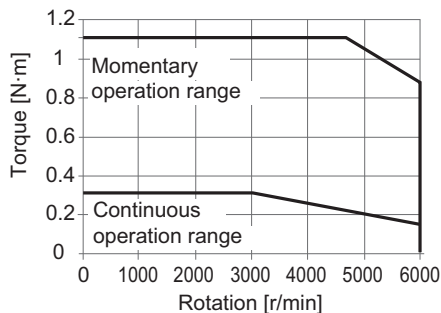

• R88M-1M20030H

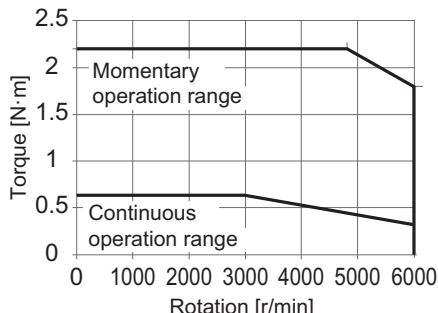

• R88M-1M40030H

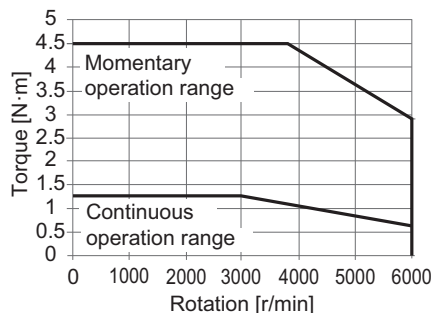

• R88M-1M75030H

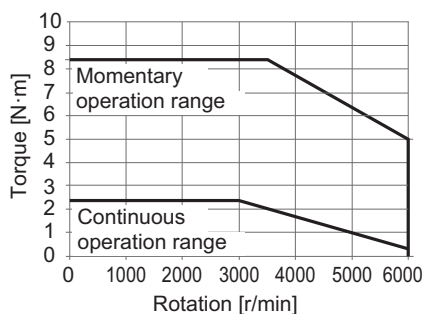

• R88M-1L1K030H

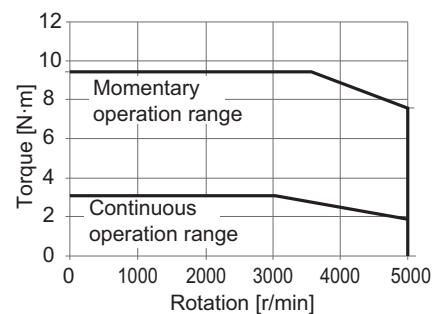

• R88M-1L1K530H

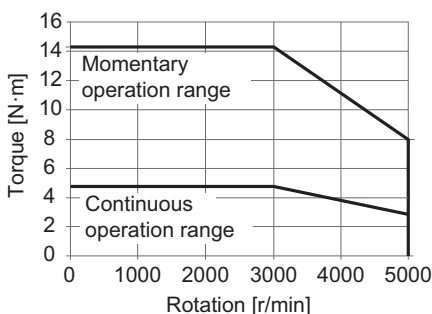

Note The continuous operation range is the range in which continuous operation is possible at an ambient temperature of 40°C when the Servomotor is horizontally installed on a specified radiator plate. Continuous operation at the maximum speed is also possible. However, doing so will reduce the output torque.

2,000-r/min Servomotors

Item	Model (R88M-)		200 VAC	
		Unit	1M1K020H	1M1K520H
Rated output ^{*1*2}		W	1,000	1,500
Rated torque ^{*1*2}		N·m	4.77	7.16
Rated rotation speed ^{*1*2}		r/min	2,000	
Maximum rotation speed		r/min	3,000	
Momentary maximum torque ^{*1}		N·m	14.3	21.5
Rated current ^{*1*2}		A (rms)	5.2	8.6
Momentary maximum current ^{*1}		A (rms)	16.9	28.4
Rotor inertia	Without brake	10 ⁻⁴ kg·m ²	6.0042	9.0042
	With brake	10 ⁻⁴ kg·m ²	6.5042	9.5042
Applicable load inertia		10 ⁻⁴ kg·m ²	59.0	79.9
Torque constant ^{*1}		N·m/A (rms)	0.93	0.83
Power rate ^{*1*3}		kW/s	38	57
Mechanical time constant ^{*3}		ms	0.94	0.78
Electrical time constant		ms	13	15
Allowable radial load ^{*4}		N	490	
Allowable thrust load ^{*4}		N	196	
Weight	Without brake	kg	6.6	8.5
	With brake	kg	8.6	10.5
Radiator plate dimensions (material)		mm	400 × 400 × t20 (aluminum)	470 × 470 × t20 (aluminum)
Brake specifications	Excitation voltage ^{*5}	V	24 VDC±10%	
	Current consumption (at 20°C)	A	0.51	0.51
	Static friction torque	N·m	9.0 min.	9.0 min.
	Attraction time	ms	100 max.	100 max.
	Release time ^{*6}	ms	30 max.	30 max.
	Backlash	°	0.6 max.	0.6 max.
	Allowable braking work	J	1,000	1,000
	Allowable total work	J	3,000,000	3,000,000
	Allowable angular acceleration	rad/s ²	10,000 max.	
	Brake lifetime (acceleration/deceleration)	---	10 million times min.	
Insulation class	---	Class F		

*1. This is a typical value for when the Servomotor is used at a normal temperature (20°C, 65%) in combination with a Servo Drive.

*2. The rated values are the values with which continuous operation is possible at an ambient temperature of 40°C when the Servomotor is horizontally installed on a specified radiator plate.

*3. This value is for models without options.

- *4. The allowable radial and thrust loads are the values determined for a limit of 20,000 hours at normal operating temperatures.

The allowable radial loads are applied as shown in the following diagram.

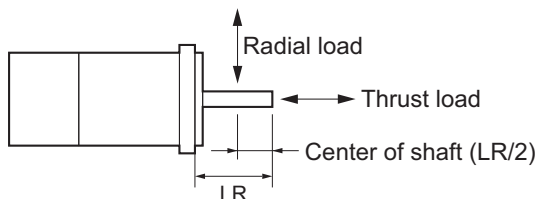

- *5. This is a non-excitation brake. It is released when excitation voltage is applied.
- *6. This value is a reference value.

● Torque-Rotation Speed Characteristics for 2,000-r/min Servomotors (200 VAC)

The following graphs show the characteristics with a 3-m standard cable and a 3-phase 200-VAC or single-phase 220-VAC input.

• R88M-1M1K020H

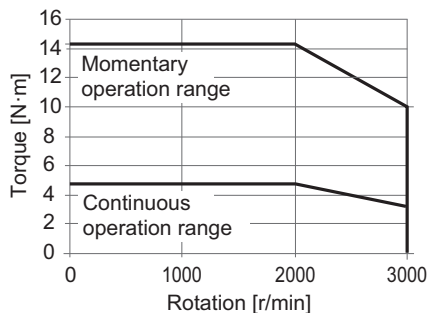

• R88M-1M1K520H

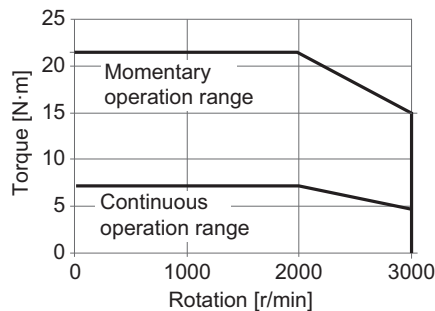

Note The continuous operation range is the range in which continuous operation is possible at an ambient temperature of 40°C when the Servomotor is horizontally installed on a specified radiator plate. Continuous operation at the maximum speed is also possible. However, doing so will reduce the output torque.

3-3 Cable and Connector Specifications

This section describes the specifications of the cables to connect between Servo Drives and Servomotors, and the connectors to be used.

Select an appropriate cable for the Servomotor.

3-3-1 Encoder Cable Specifications

These cables are used to connect the Servo Drive with an encoder installed in the Servomotor. Select an appropriate cable for the Servomotor.



Precautions for Correct Use

If the cable is used in a moving part, use a flexible cable.

The protective structure rating of the Servomotor with an encoder cable whose length [L] is 30 m or more is IP20.

Encoder Cables (Standard Cable)

● R88A-CR1A□□□C

Applicable Servomotors

200 V:

3,000-r/min Servomotors of 100 W, 200 W, 400 W, and 750 W

Cable types

Model	Length [L]	Outer diameter of sheath	Weight
R88A-CR1A003C	3 m	5.3 dia.	Approx. 0.3 kg
R88A-CR1A005C	5 m		Approx. 0.4 kg
R88A-CR1A010C	10 m		Approx. 0.7 kg
R88A-CR1A015C	15 m		Approx. 1.0 kg
R88A-CR1A020C	20 m		Approx. 1.4 kg
R88A-CR1A030C	30 m	6.0 dia.	Approx. 2.2 kg
R88A-CR1A040C	40 m		Approx. 3.0 kg
R88A-CR1A050C	50 m		Approx. 3.7 kg

Connection configuration and external dimensions [mm]

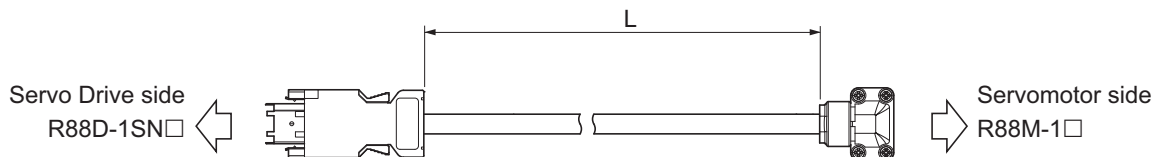

Wiring

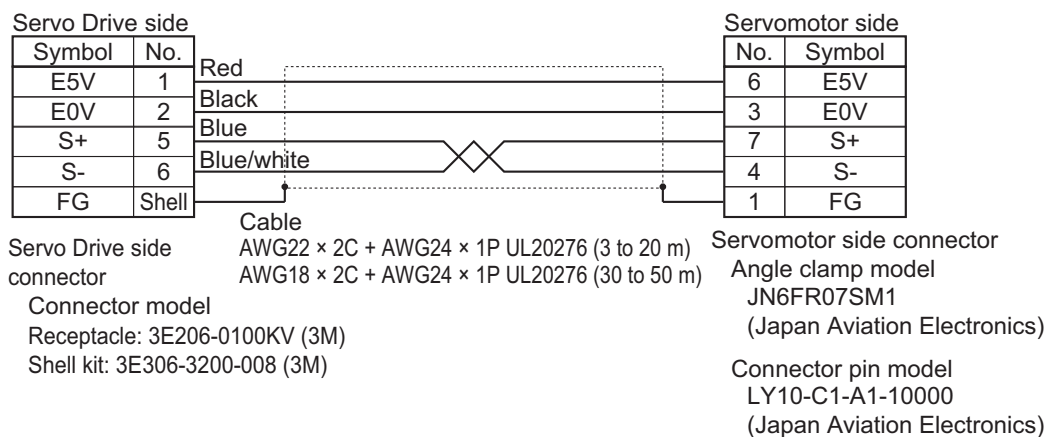

● **R88A-CR1B□□□N**

Applicable Servomotors

200 V:

3,000-r/min Servomotors of 1 kW, 2,000-r/min Servomotors

Cable types

Model	Length [L]	Outer diameter of sheath	Weight
R88A-CR1B003N	3 m	6.0 dia.	Approx. 0.3 kg
R88A-CR1B005N	5 m		Approx. 0.4 kg
R88A-CR1B010N	10 m		Approx. 0.8 kg
R88A-CR1B015N	15 m		Approx. 1.1 kg
R88A-CR1B020N	20 m		Approx. 1.5 kg
R88A-CR1B030N	30 m		Approx. 2.3 kg
R88A-CR1B040N	40 m		Approx. 3.0 kg
R88A-CR1B050N	50 m		Approx. 3.7 kg

Connection configuration and external dimensions [mm]

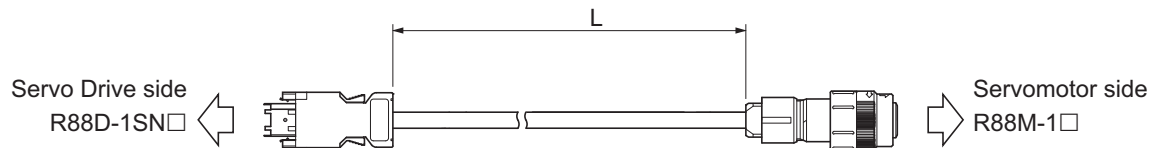

Wiring

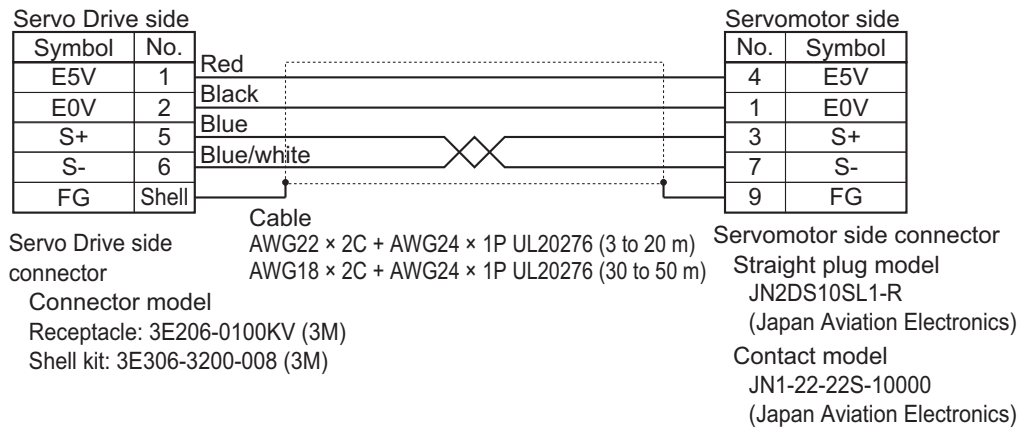

Encoder Cables (Flexible Cable)

● R88A-CR1A□□□CF

Applicable Servomotors

200 V:

3,000-r/min Servomotors of 100 W, 200 W, 400 W, and 750 W

Cable types

Model	Length [L]	Outer diameter of sheath	Minimum bending radius	Weight
R88A-CR1A003CF	3 m	5.3 dia.	33 mm	Approx. 0.3 kg
R88A-CR1A005CF	5 m			Approx. 0.4 kg
R88A-CR1A010CF	10 m			Approx. 0.7 kg
R88A-CR1A015CF	15 m			Approx. 1.0 kg
R88A-CR1A020CF	20 m			Approx. 1.4 kg
R88A-CR1A030CF	30 m	6.0 dia.	42 mm	Approx. 2.2 kg
R88A-CR1A040CF	40 m			Approx. 3.0 kg
R88A-CR1A050CF	50 m			Approx. 3.7 kg

Connection configuration and external dimensions [mm]

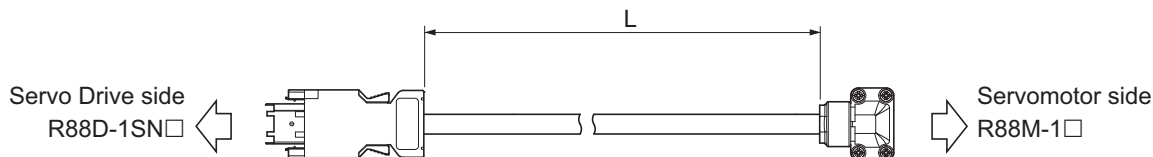

Wiring

Servo Drive side

Symbol	No.
E5V	1
E0V	2
S+	5
S-	6
FG	Shell

Servo Drive side connector

Connector model

Receptacle: 3E206-0100KV (3M)

Shell kit: 3E306-3200-008 (3M)

Servomotor side

No.	Symbol
6	E5V
3	E0V
7	S+
4	S-
1	FG

Servomotor side connector

Angle clamp model

JN6FR07SM1 (Japan Aviation Electronics)

Connector pin model

LY10-C1-A1-10000 (Japan Aviation Electronics)

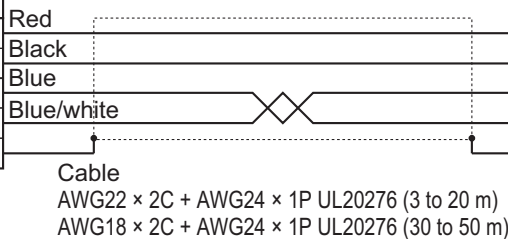

● **R88A-CR1B□□□NF**

Applicable Servomotors

200 V:

3,000-r/min Servomotors of 1 kW and 2,000-r/min Servomotors

Cable types

Model	Length [L]	Outer diameter of sheath	Minimum bending radius	Weight
R88A-CR1B003NF	3 m	6.0 dia.	33 mm	Approx. 0.3 kg
R88A-CR1B005NF	5 m			Approx. 0.4 kg
R88A-CR1B010NF	10 m			Approx. 0.8 kg
R88A-CR1B015NF	15 m			Approx. 1.1 kg
R88A-CR1B020NF	20 m			Approx. 1.5 kg
R88A-CR1B030NF	30 m			42 mm
R88A-CR1B040NF	40 m	Approx. 3.0 kg		
R88A-CR1B050NF	50 m	Approx. 3.7 kg		

Connection configuration and external dimensions [mm]

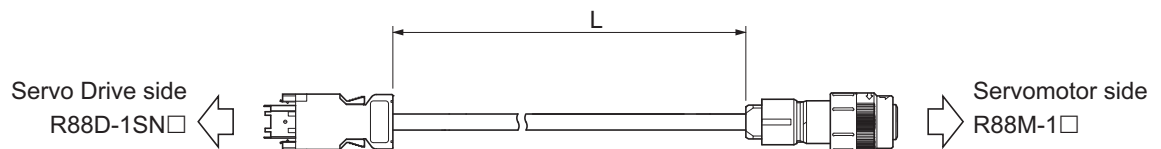

Wiring

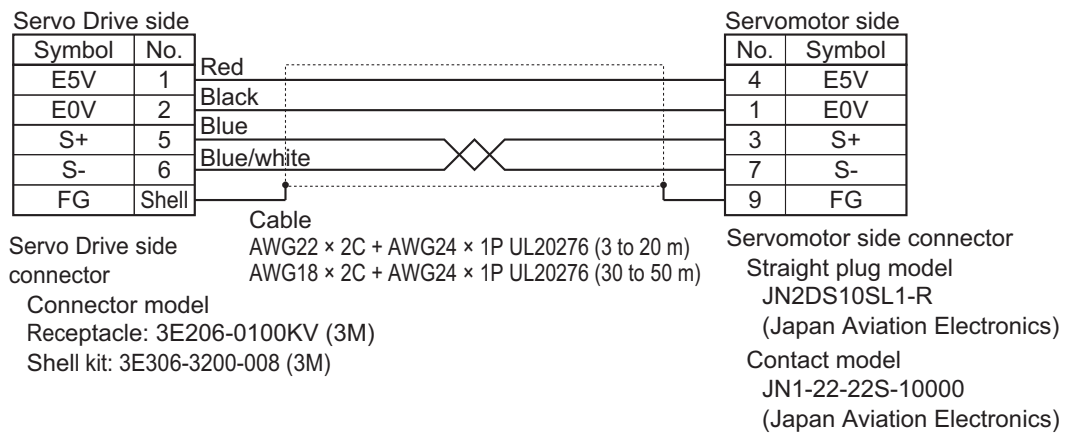

3-3-2 Motor Power Cable Specifications

These cables are used to connect the Servo Drive and Servomotor. Select an appropriate cable for the Servomotor.



Precautions for Correct Use

If the cable is used in a moving part, use a flexible cable.

Power Cables without Brake Wire (Standard Cable)

● **R88A-CA1A□□□S**

Applicable Servomotors

200 V:

3,000-r/min Servomotors of 100 W, 200 W, 400 W, and 750 W

Cable types

Model	Length [L]	Outer diameter of sheath	Weight
R88A-CA1A003S	3 m	6.8 dia.	Approx. 0.4 kg
R88A-CA1A005S	5 m		Approx. 0.6 kg
R88A-CA1A010S	10 m		Approx. 1.1 kg
R88A-CA1A015S	15 m		Approx. 1.5 kg
R88A-CA1A020S	20 m		Approx. 2.0 kg
R88A-CA1A030S	30 m		Approx. 3.0 kg
R88A-CA1A040S	40 m		Approx. 4.0 kg
R88A-CA1A050S	50 m		Approx. 5.0 kg

Connection configuration and external dimensions [mm]

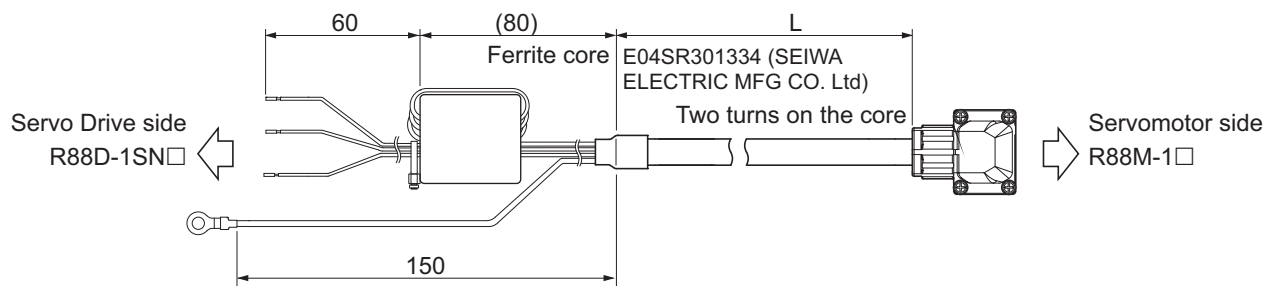

Wiring

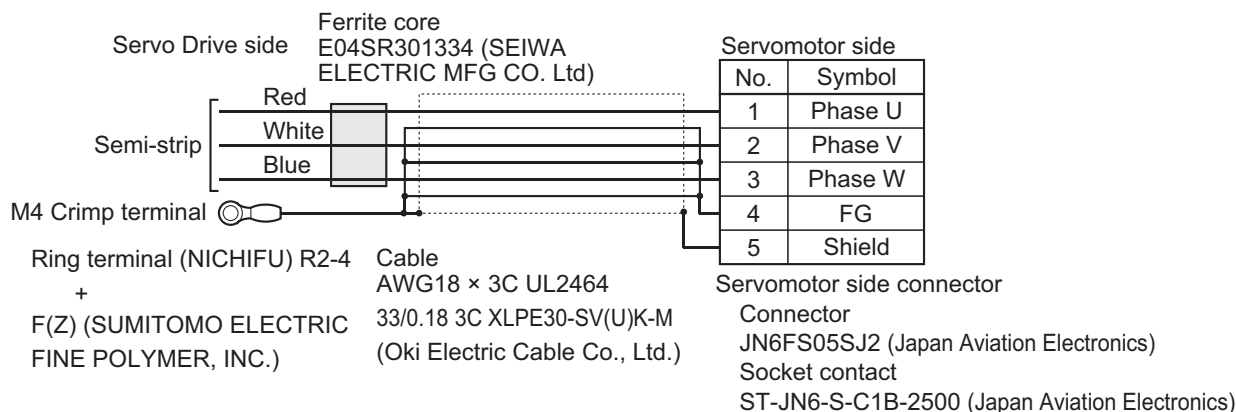

● **R88A-CA1B□□□S**

Applicable Servomotors

200 V:

3,000-r/min Servomotors of 1 kW and 2,000-r/min Servomotors of 1 kW

Cable types

Model	Length [L]	Outer diameter of sheath	Weight
R88A-CA1B003S	3 m	10.8 dia.	Approx. 1.0 kg
R88A-CA1B005S	5 m		Approx. 1.6 kg
R88A-CA1B010S	10 m		Approx. 2.9 kg
R88A-CA1B015S	15 m		Approx. 4.3 kg
R88A-CA1B020S	20 m		Approx. 5.7 kg
R88A-CA1B030S	30 m		Approx. 8.4 kg
R88A-CA1B040S	40 m		Approx. 11.1 kg
R88A-CA1B050S	50 m		Approx. 13.8 kg

Connection configuration and external dimensions [mm]

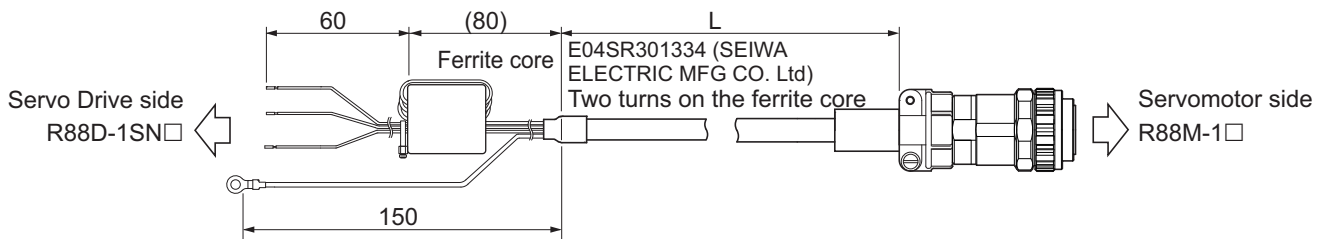

Wiring

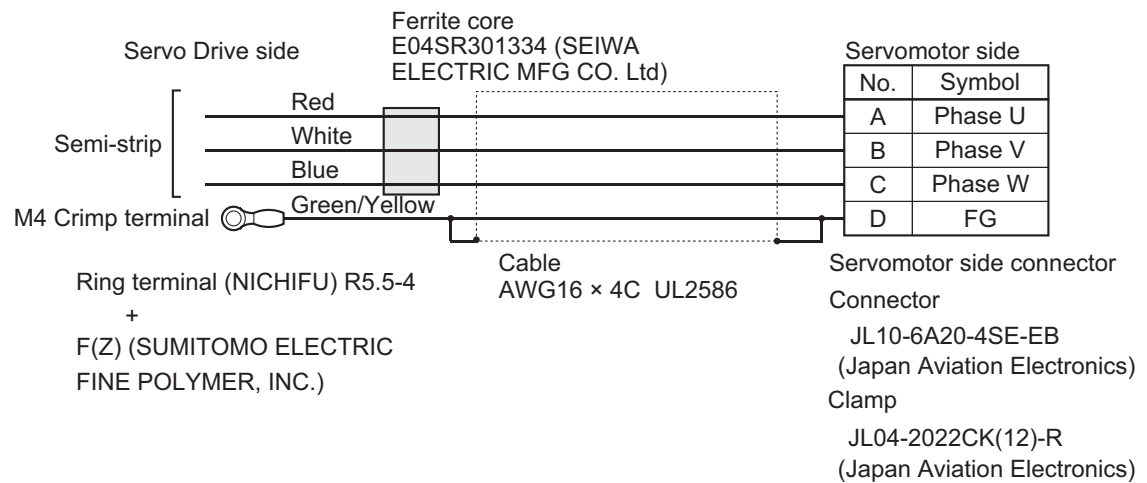

● **R88A-CA1C□□□S**

Applicable Servomotors

200 V:

3,000-r/min Servomotors of 1.5 kW and 2,000-r/min Servomotors of 1.5 kW

Cable types

Model	Length [L]	Outer diameter of sheath	Weight
R88A-CA1C003S	3 m	10.8 dia.	Approx. 1.0 kg
R88A-CA1C005S	5 m		Approx. 1.6 kg
R88A-CA1C010S	10 m		Approx. 2.9 kg
R88A-CA1C015S	15 m		Approx. 4.3 kg
R88A-CA1C020S	20 m		Approx. 5.7 kg
R88A-CA1C030S	30 m		Approx. 8.4 kg
R88A-CA1C040S	40 m		Approx. 11.1 kg
R88A-CA1C050S	50 m		Approx. 13.8 kg

Connection configuration and external dimensions [mm]

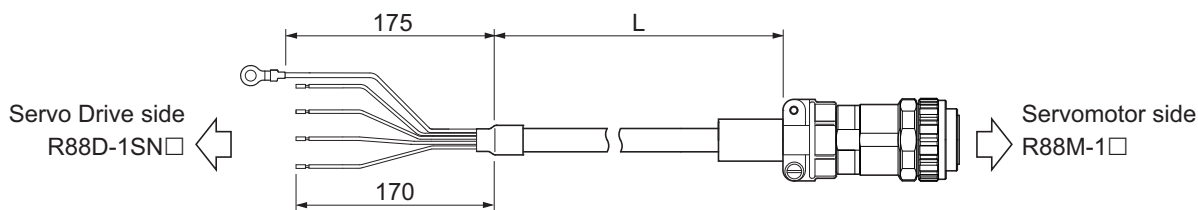

Wiring

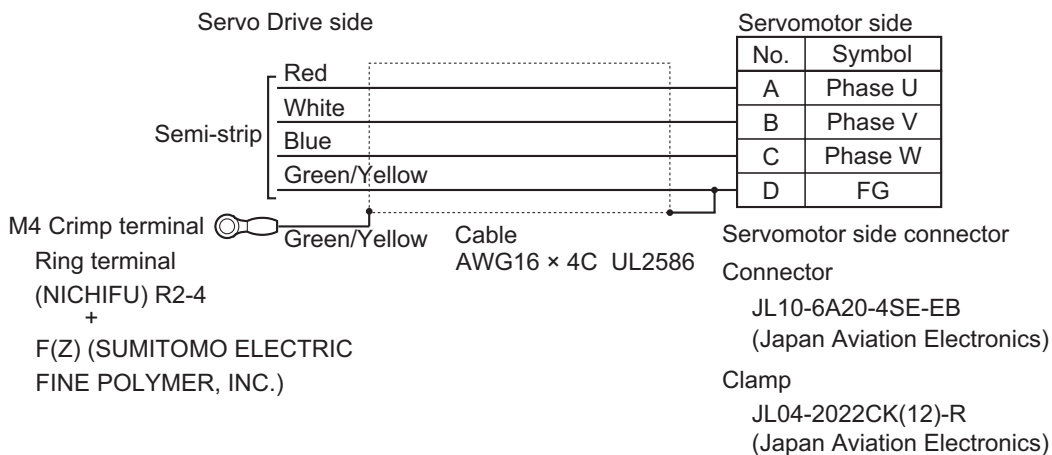

Power Cables without Brake Wire (Flexible Cable)

● R88A-CA1A□□□SF

Applicable Servomotors

200 V:

3,000-r/min Servomotors of 100 W, 200 W, 400 W, and 750 W

Cable types

Model	Length [L]	Outer diameter of sheath	Minimum bending radius	Weight
R88A-CA1A003SF	3 m	6.8 dia.	40 mm	Approx. 0.4 kg
R88A-CA1A005SF	5 m			Approx. 0.6 kg
R88A-CA1A010SF	10 m			Approx. 1.1 kg
R88A-CA1A015SF	15 m			Approx. 1.5 kg
R88A-CA1A020SF	20 m			Approx. 2.0 kg
R88A-CA1A030SF	30 m			Approx. 3.0 kg
R88A-CA1A040SF	40 m			Approx. 4.0 kg
R88A-CA1A050SF	50 m			Approx. 5.0 kg

Connection configuration and external dimensions [mm]

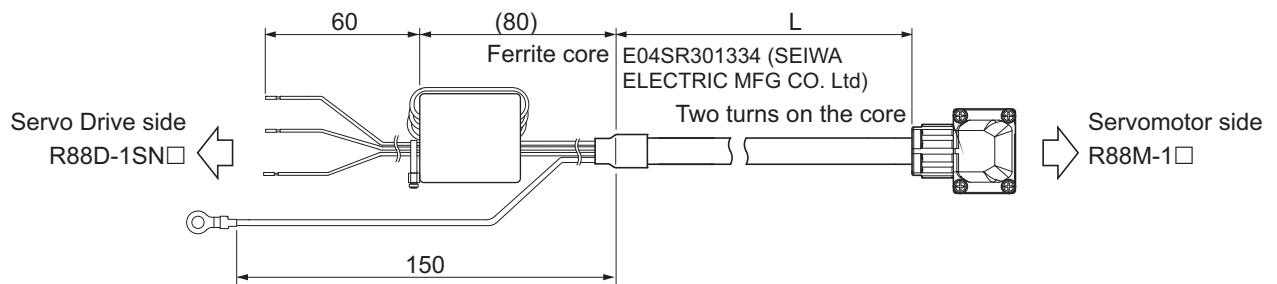

Wiring

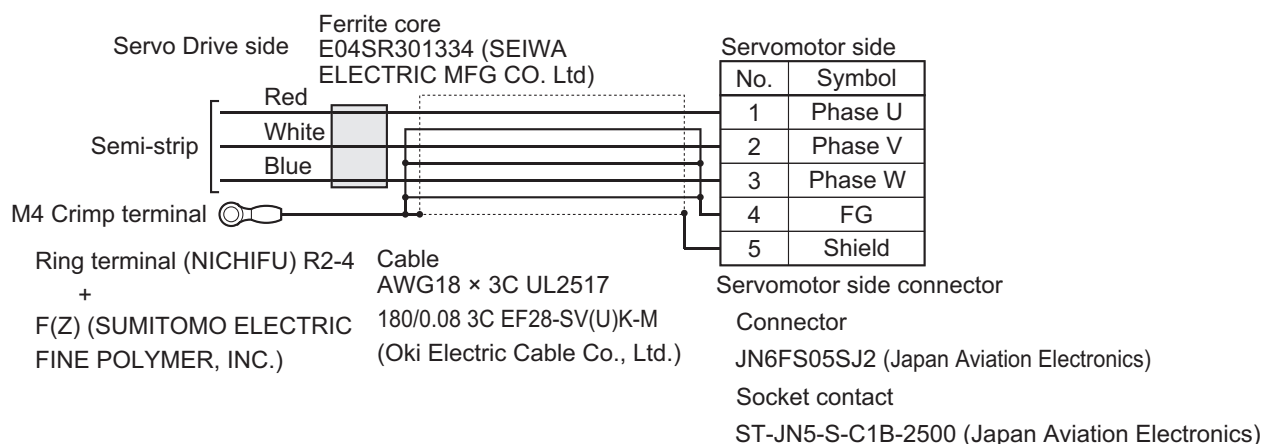

● **R88A-CA1B□□□SF**

Applicable Servomotors

200 V:

3,000-r/min Servomotors of 1 kW and 2,000-r/min Servomotors of 1 kW

Cable types

Model	Length [L]	Outer diameter of sheath	Minimum bending radius	Weight
R88A-CA1B003SF	3 m	10.8 dia.	90 mm	Approx. 1.0 kg
R88A-CA1B005SF	5 m			Approx. 1.6 kg
R88A-CA1B010SF	10 m			Approx. 2.9 kg
R88A-CA1B015SF	15 m			Approx. 4.3 kg
R88A-CA1B020SF	20 m			Approx. 5.7 kg
R88A-CA1B030SF	30 m			Approx. 8.4 kg
R88A-CA1B040SF	40 m			Approx. 11.1 kg
R88A-CA1B050SF	50 m			Approx. 13.8 kg

Connection configuration and external dimensions [mm]

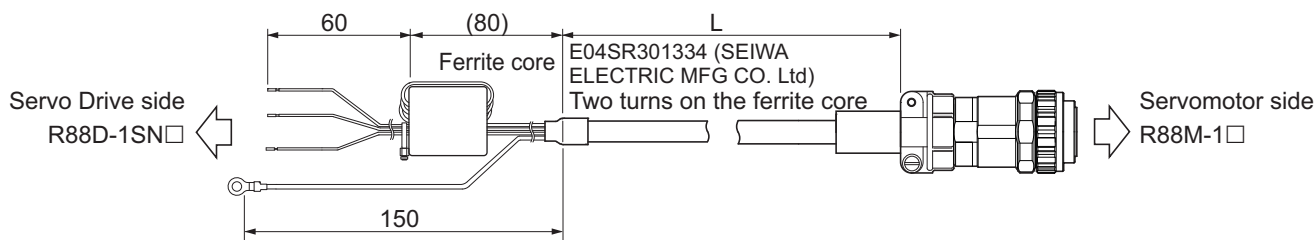

Wiring

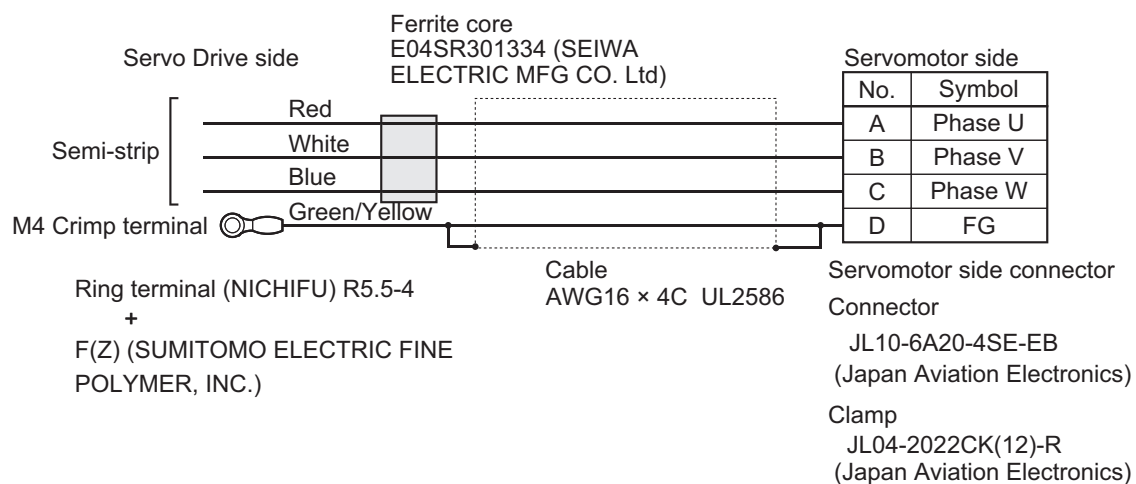

● **R88A-CA1C□□□SF**

Applicable Servomotors

200 V:

3,000-r/min Servomotors of 1.5 kW

2,000-r/min Servomotors of 1.5 kW

Cable types

Model	Length [L]	Outer diameter of sheath	Minimum bending radius	Weight
R88A-CA1C003SF	3 m	10.8 dia.	90 mm	Approx. 1.0 kg
R88A-CA1C005SF	5 m			Approx. 1.6 kg
R88A-CA1C010SF	10 m			Approx. 2.9 kg
R88A-CA1C015SF	15 m			Approx. 4.3 kg
R88A-CA1C020SF	20 m			Approx. 5.7 kg
R88A-CA1C030SF	30 m			Approx. 8.4 kg
R88A-CA1C040SF	40 m			Approx. 11.1 kg
R88A-CA1C050SF	50 m			Approx. 13.8 kg

Connection configuration and external dimensions [mm]

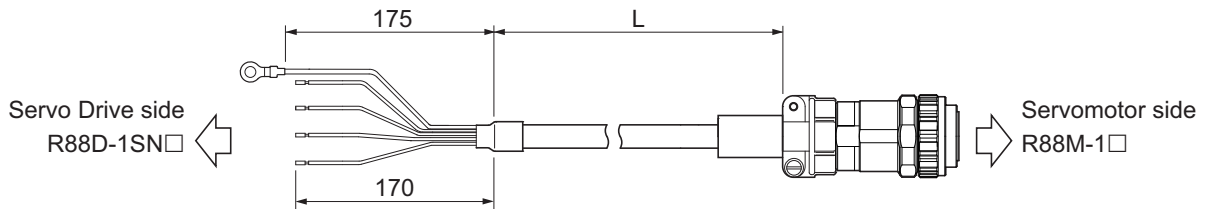

Wiring

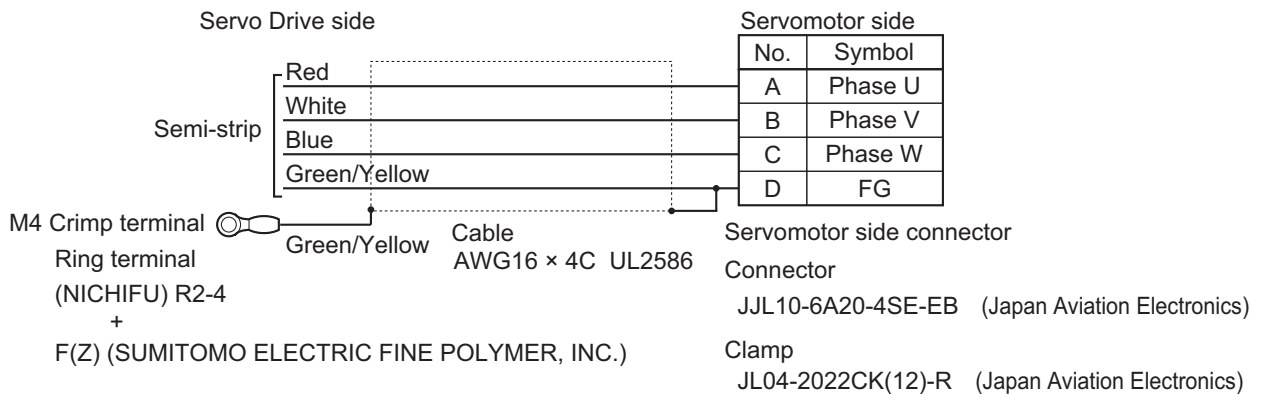

Power Cables with Brake Wire (Standard Cable)

● R88A-CA1B□□□B

Applicable Servomotors

200 V:

3,000-r/min Servomotors of 1 kW

2,000-r/min Servomotors of 1 kW

Cable types

Model	Length [L]	Outer diameter of sheath	Weight
R88A-CA1B003B	3 m	12.5 dia.	Approx. 1.2 kg
R88A-CA1B005B	5 m		Approx. 1.9 kg
R88A-CA1B010B	10 m		Approx. 3.5 kg
R88A-CA1B015B	15 m		Approx. 5.1 kg
R88A-CA1B020B	20 m		Approx. 6.7 kg
R88A-CA1B030B	30 m		Approx. 10.0 kg
R88A-CA1B040B	40 m		Approx. 13.2 kg
R88A-CA1B050B	50 m		Approx. 16.5 kg

Connection configuration and external dimensions [mm]

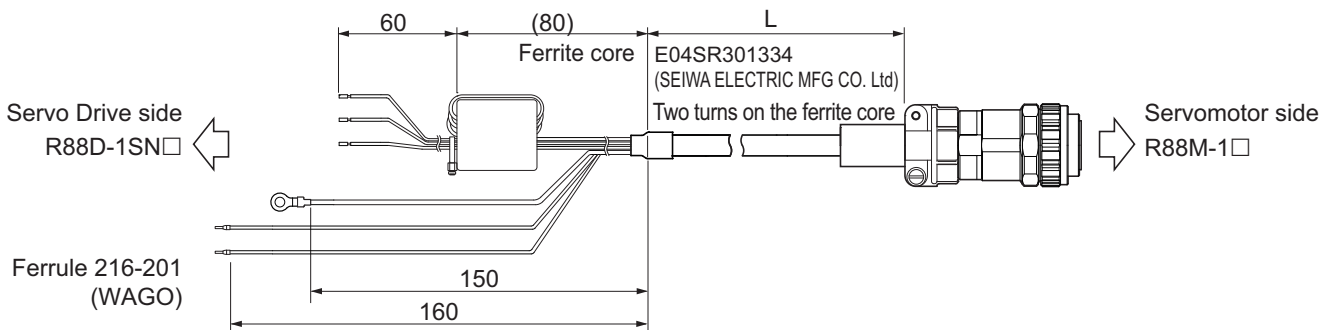

Wiring

Servo Drive side

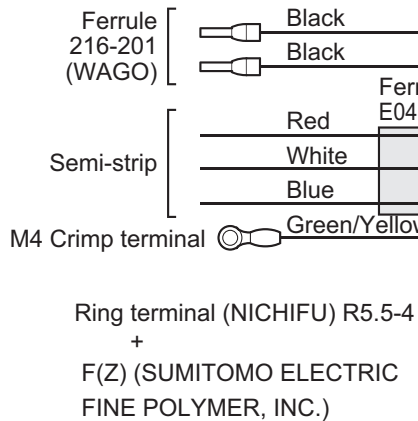

Servomotor side

No.	Symbol
G	Brake
H	Brake
A	NC
F	Phase U
I	Phase V
B	Phase W
E	FG
D	FG
C	NC

Servomotor side connector

Connector
JL10-6A20-18SE-EB
(Japan Aviation Electronics)
Clamp
JL04-2022CK(12)-R
(Japan Aviation Electronics)

● **R88A-CA1C□□□B**

Applicable Servomotors

200 V:

3,000-r/min Servomotors of 1.5 kW

2,000-r/min Servomotors of 1.5 kW

Cable types

Model	Length [L]	Outer diameter of sheath	Weight
R88A-CA1C003B	3 m	12.5 dia.	Approx. 1.2 kg
R88A-CA1C005B	5 m		Approx. 1.9 kg
R88A-CA1C010B	10 m		Approx. 3.5 kg
R88A-CA1C015B	15 m		Approx. 5.1 kg
R88A-CA1C020B	20 m		Approx. 6.7 kg
R88A-CA1C030B	30 m		Approx. 10.0 kg
R88A-CA1C040B	40 m		Approx. 13.2 kg
R88A-CA1C050B	50 m		Approx. 16.5 kg

Connection configuration and external dimensions [mm]

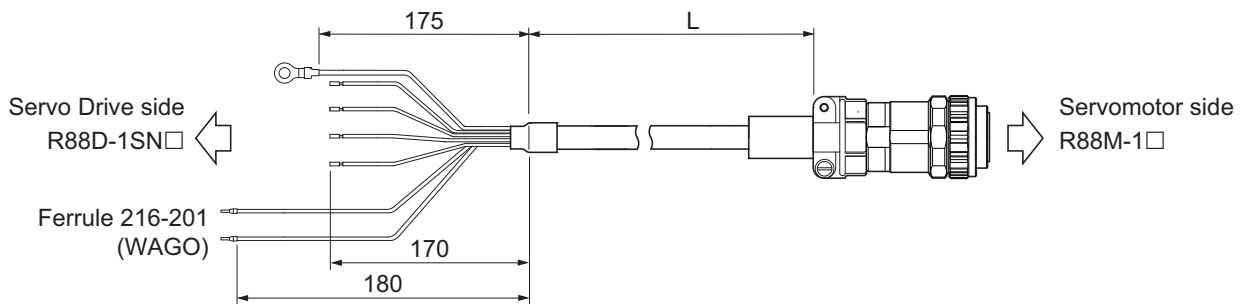

Wiring

Servo Drive side

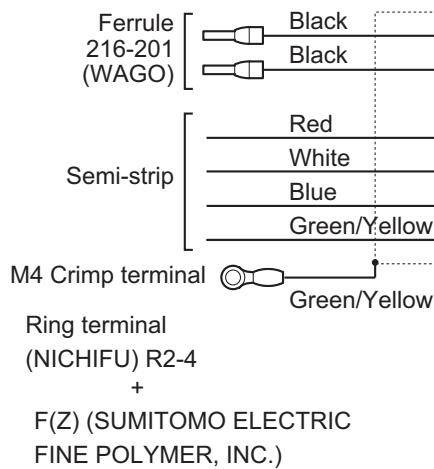

Servomotor side

No.	Symbol
G	Brake
H	Brake
A	NC
F	Phase U
I	Phase V
B	Phase W
E	FG
D	FG
C	NC

Servomotor side connector

Connector
JL10-6A20-18SE-EB
(Japan Aviation Electronics)
Clamp
JL04-2022CK(12)-R
(Japan Aviation Electronics)

Power Cables with Brake Wire (Flexible Cable)

● R88A-CA1B□□□BF

Applicable Servomotors

200 V:

3,000-r/min Servomotors of 1 kW

2,000-r/min Servomotors of 1 kW

Cable types

Model	Length [L]	Outer diameter of sheath	Minimum bending radius	Weight
R88A-CA1B003BF	3 m	12.5 dia.	90 mm	Approx. 1.2 kg
R88A-CA1B005BF	5 m			Approx. 1.9 kg
R88A-CA1B010BF	10 m			Approx. 3.5 kg
R88A-CA1B015BF	15 m			Approx. 5.1 kg
R88A-CA1B020BF	20 m			Approx. 6.7 kg
R88A-CA1B030BF	30 m			Approx. 10.0 kg
R88A-CA1B040BF	40 m			Approx. 13.2 kg
R88A-CA1B050BF	50 m			Approx. 16.5 kg

Connection configuration and external dimensions [mm]

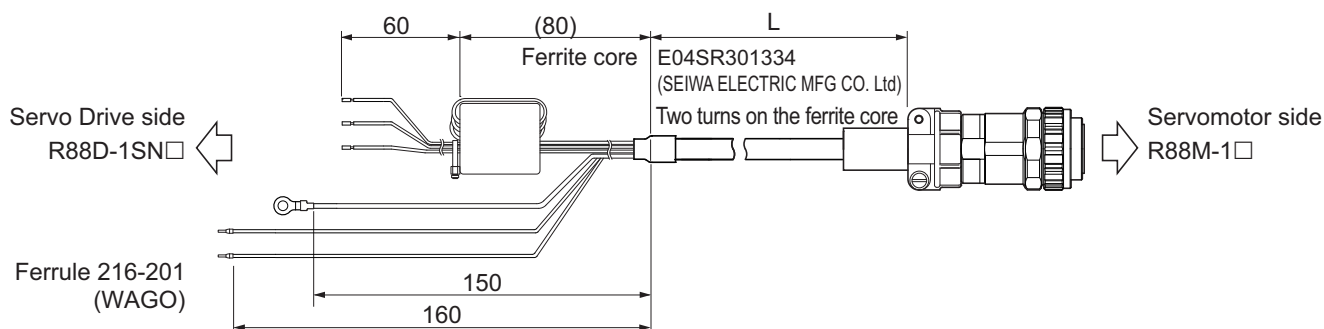

Wiring

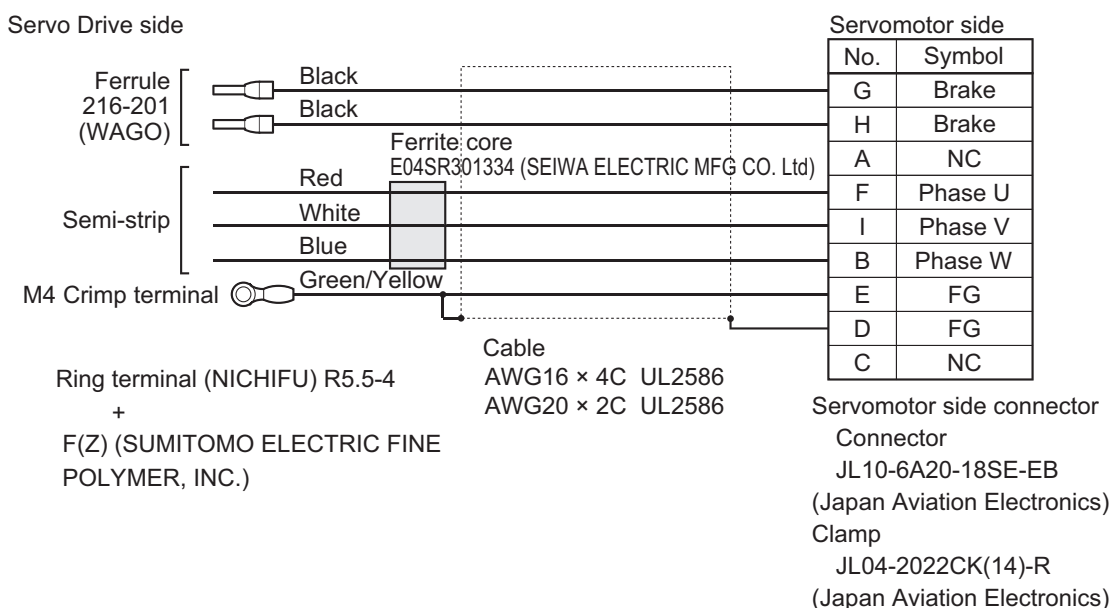

● **R88A-CA1C□□□BF**

Applicable Servomotors

200 V:

3,000-r/min Servomotors of 1.5 kW

2,000-r/min Servomotors of 1.5 kW

Cable types

Model	Length [L]	Outer diameter of sheath	Minimum bending radius	Weight
R88A-CA1C003BF	3 m	12.5 dia.	90 mm	Approx. 1.2 kg
R88A-CA1C005BF	5 m			Approx. 1.9 kg
R88A-CA1C010BF	10 m			Approx. 3.5 kg
R88A-CA1C015BF	15 m			Approx. 5.1 kg
R88A-CA1C020BF	20 m			Approx. 6.7 kg
R88A-CA1C030BF	30 m			Approx. 10.0 kg
R88A-CA1C040BF	40 m			Approx. 13.2 kg
R88A-CA1C050BF	50 m			Approx. 16.5 kg

Connection configuration and external dimensions [mm]

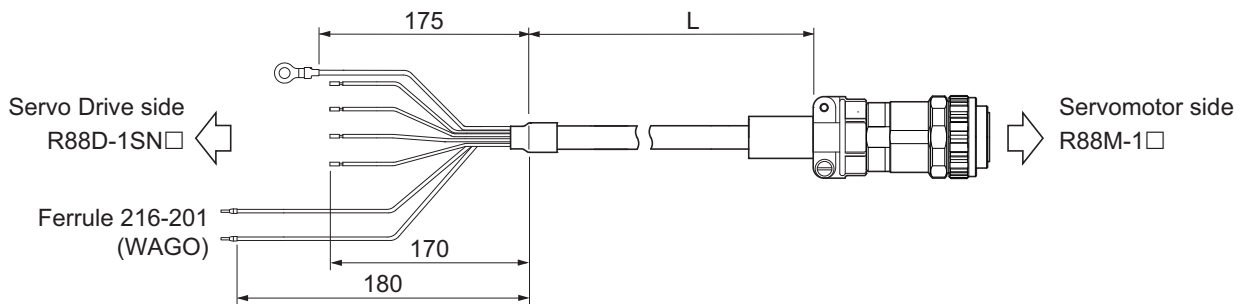

Wiring

Servo Drive side

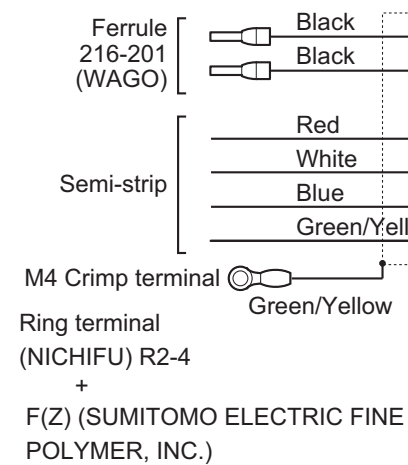

Servomotor side

No.	Symbol
G	Brake
H	Brake
A	NC
F	Phase U
I	Phase V
B	Phase W
E	FG
D	FG
C	NC

Servomotor side connector

Connector
JL10-6A20-18SE-EB
(Japan Aviation Electronics)
Clamp
JL04-2022CK(12)-R
(Japan Aviation Electronics)

Brake Cables (Standard Cable)

● R88A-CA1A□□□B

Applicable Servomotors

200 V:

3,000-r/min Servomotors of 100 W, 200 W, 400 W, and 750 W

Cable types

Model	Length [L]	Outer diameter of sheath	Weight
R88A-CA1A003B	3 m	5.0 dia.	Approx. 0.2 kg
R88A-CA1A005B	5 m		Approx. 0.3 kg
R88A-CA1A010B	10 m		Approx. 0.5 kg
R88A-CA1A015B	15 m		Approx. 0.7 kg
R88A-CA1A020B	20 m		Approx. 0.9 kg
R88A-CA1A030B	30 m		Approx. 1.4 kg
R88A-CA1A040B	40 m		Approx. 1.8 kg
R88A-CA1A050B	50 m		Approx. 2.3 kg

Connection configuration and external dimensions [mm]

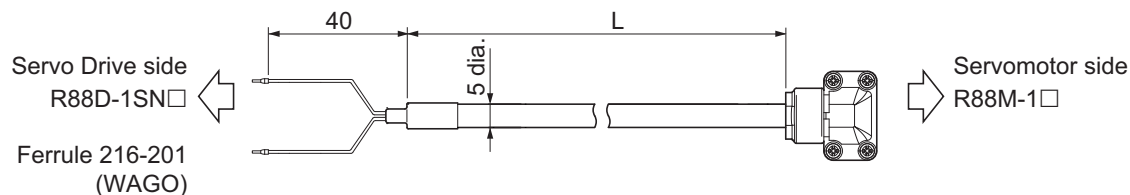

Wiring

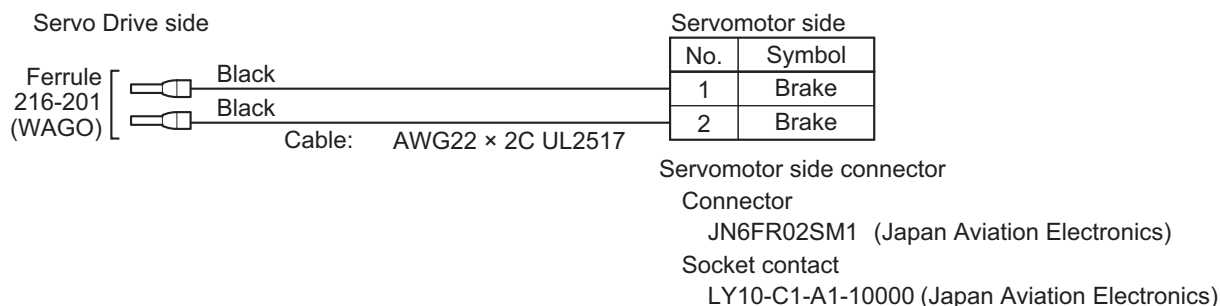

Brake Cables (Flexible Cable)

● R88A-CA1A□□□BF

Applicable Servomotors

200 V:

3,000-r/min Servomotors of 100 W, 200 W, 400 W, and 750 W

Cable types

Model	Length [L]	Outer diameter of sheath	Minimum bending radius	Weight
R88A-CA1A003BF	3 m	5.0 dia.	30 mm	Approx. 0.2 kg
R88A-CA1A005BF	5 m			Approx. 0.3 kg
R88A-CA1A010BF	10 m			Approx. 0.5 kg
R88A-CA1A015BF	15 m			Approx. 0.7 kg
R88A-CA1A020BF	20 m			Approx. 0.9 kg
R88A-CA1A030BF	30 m			Approx. 1.4 kg
R88A-CA1A040BF	40 m			Approx. 1.8 kg
R88A-CA1A050BF	50 m			Approx. 2.3 kg

Connection configuration and external dimensions [mm]

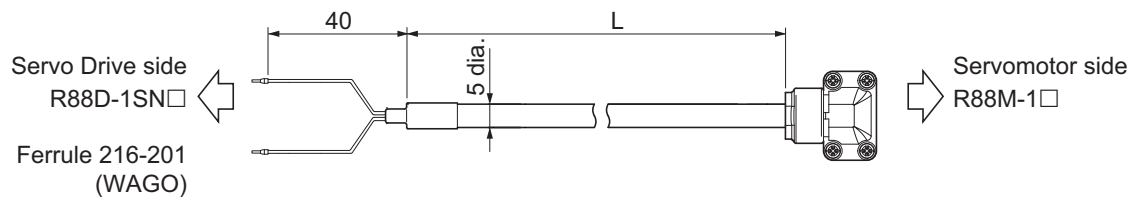

Wiring

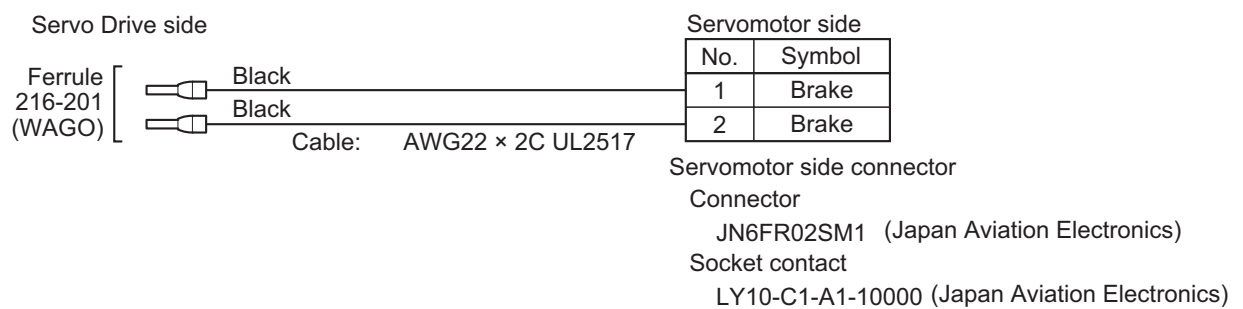

3-3-3 Resistance to Bending of Flexible Cable

If the cable is used in a moving part, use a flexible cable.

The flexing life of a Flexible Cable is estimated under the following conditions.



Precautions for Correct Use

- Because the lifetime data on resistance to bending is intended for reference only, use the cable with a sufficient margin.
- The minimum bending radius refers to the value at which the core conductor provides electrical continuity without causing cracks and scratches that can have functional impact on the sheath, which does not cover the disconnection of shielded wire.
- Malfunction or grounding fault due to dielectric breakdown may occur if cables are used at a radius smaller than the minimum bending radius.

Moving Bend Test

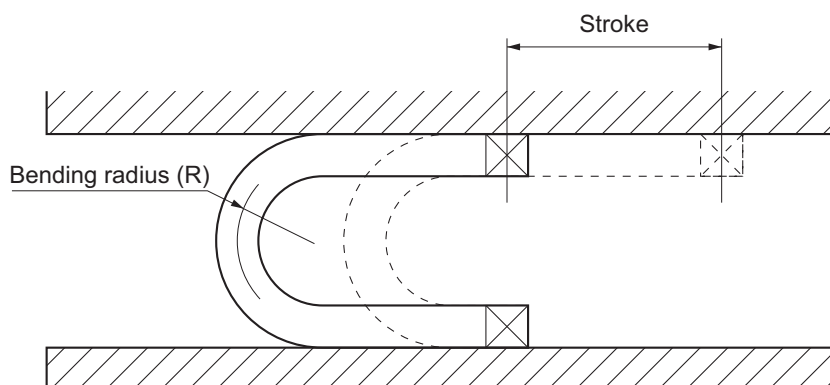

● Encoder Cable

Model	Bend test conditions		Estimated life
	Minimum bending radius [R]	Stroke	
R88A-CR1A□□□CF ^{*1}	33 mm	500 to 1,000 mm	20 million times
R88A-CR1B□□□NF ^{*1}			
R88A-CR1A△△△CF ^{*2}	42 mm	500 to 1,000 mm	20 million times
R88A-CR1B△△△NF ^{*2}			

*1. □□□ represents a number between 003 and 020.

*2. △△△ represents a number between 030 and 050.

When 030 to 050 cables are used, the bending position on the cables must be at least 100 mm away from the Servomotor's connector.

● Power Cables without Brake Wire

Model	Bend test conditions		Estimated life
	Minimum bending radius [R]	Stroke	
R88A-CA1A□□□SF* ¹	40 mm	500 mm	10 million times
R88A-CA1B□□□SF* ¹	90 mm	500 to 1,000 mm	20 million times
R88A-CA1C□□□SF* ¹			

*1. □□□ represents a number between 003 and 050.

● Power Cables with Brake Wire

Model	Bend test conditions		Estimated life
	Minimum bending radius [R]	Stroke	
R88A-CA1B□□□BF* ¹	90 mm	500 to 1,000 mm	20 million times
R88A-CA1C□□□BF* ¹			
R88A-CA1D□□□BF* ¹			

*1. □□□ represents a number between 003 and 050.

● Brake Cable

Model	Bend test conditions		Estimated life
	Minimum bending radius [R]	Stroke	
R88A-CA1A□□□BF* ¹	30 mm	500 to 1,000 mm	20 million times

*1. □□□ represents a number between 003 and 050.

3-3-4 Connector Specifications

Encoder Cable Connectors

These connectors are used for encoder cables.

Use them when you prepare an encoder cable by yourself.

● Servo Drive Connector

Item		Specifications
Applicable Servomotor		1S-series Servomotors of all capacities
Connector		This is a soldering-type connector.
	Receptacle	3E206-0100KV (3M)
	Shell kit	3E306-3200-008 (3M)
	Receptacle and shell kit	R88A-CN101R (OMRON)
Applicable cable	Applicable wire	AWG 18 max.
	Insulating cover outer diameter	2.1 mm dia. max.
	Outer diameter of sheath	5.4 to 7.5 mm dia.

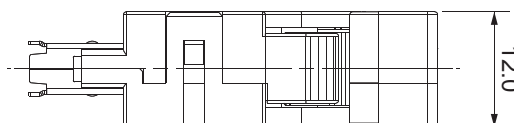
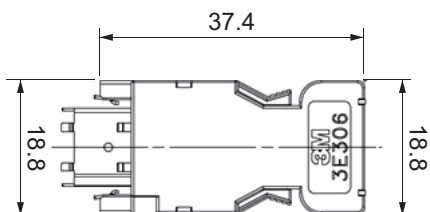

● Servomotor Connector

Item		Specifications
Applicable Servomotor	200 V	3,000-r/min Servomotors of 100 to 750 W
Connector	This is a crimping-type connector. For required tools, contact the manufacturers directly.	
	Angle plug	JN6FR07SM1 (Japan Aviation Electronics)
	Connector pin	LY10-C1-A1-10000 (Japan Aviation Electronics)
	Angle plug and connector pin	R88A-CNK02R (OMRON)
Applicable cable	Applicable wire	AWG 22 max.
	Insulating cover outer diameter	1.3 mm dia. max.
	Outer diameter of sheath	5.0±0.5 mm dia.

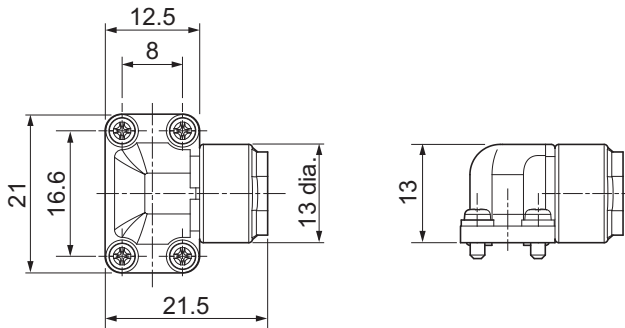

Item		Specifications
Applicable Servomotor	200 V	3,000-r/min Servomotors of 1 to 1.5 kW 2,000-r/min Servomotors of 1 to 1.5 kW
Connector	This is a crimping-type connector. For required tools, contact the manufacturers directly.	
	Straight plug	JN2DS10SL1-R (Japan Aviation Electronics)
	Contact	JN1-22-22S-10000 (Japan Aviation Electronics)
	Straight plug and contact	R88A-CN104R (OMRON)
Applicable cable	Applicable wire	AWG 20 max.
	Outer diameter of sheath	5.7 to 7.3 mm dia.

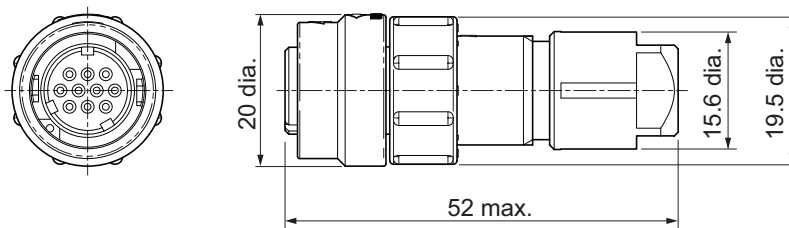

Power Cable Connector

This connector is used for power cables.

Use it when you prepare a power cable by yourself.

Item		Specifications
Applicable Servo-motor	200 V	3,000-r/min Servomotors of 100 to 750 W
Connector		This is a crimping-type connector. For required tools, contact the manufacturers directly.
	Angle plug	JN6FS05SJ2 (Japan Aviation Electronics)
	Socket contact	ST-JN6-S-C1B-2500 (Japan Aviation Electronics)
	Angle plug and socket contact	R88A-CN111A (OMRON)
Applicable cable	Applicable wire	AWG 18
	Insulating cover outer diameter	1.7 to 1.9 mm dia.
	Outer diameter of sheath	6.4 to 7.2 mm dia.

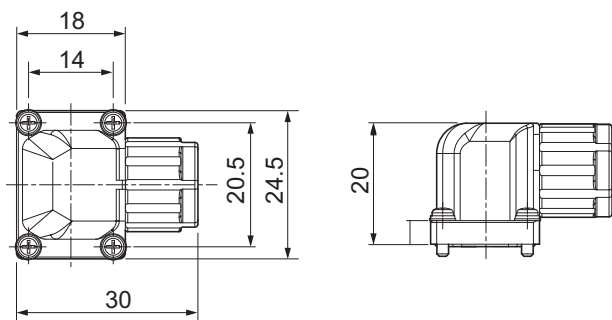

Brake Cable Connector

This connector is used for brake cables.

Use it when you prepare a brake cable by yourself.

Item		Specifications
Applicable Servo-motor	200 V	3,000-r/min Servomotors of 100 to 750 W
Connector		This is a crimping-type connector. For required tools, contact the manufacturers directly.
	Angle plug	JN6FR02SM1 (Japan Aviation Electronics)
	Socket contact	LY10-C1-A1-10000 (Japan Aviation Electronics)
	Angle plug and socket contact	R88A-CN111B (OMRON)
Applicable cable	Applicable wire	AWG 22 to 26
	Insulating cover outer diameter	0.8 to 1.3 mm dia.
	Outer diameter of sheath	4.5 to 5.5 mm dia.

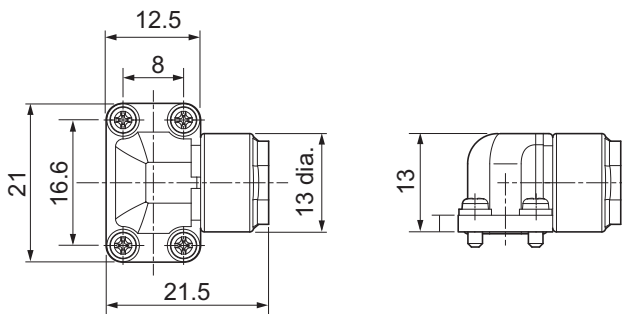

4

Configuration and Wiring

This section explains the conditions for installing, Servomotors, and the wiring methods including wiring conforming to EMC Directives.

For the Servo Drive installation conditions, the regenerative energy calculation methods, and the performance of External Regeneration Resistors, refer to the *AC Servomotors/Servo Drives 1S-series with Built-in EtherCAT® Communications User's Manual (I586)*.

4-1	Installation Conditions	4-2
4-1-1	Servomotor Installation Conditions	4-2
4-2	Wiring	4-5
4-2-1	Connector Attachment Procedure	4-5
4-2-2	Power/Brake Connector Attachment Procedure	4-7
4-3	Wiring Conforming to EMC Directives	4-8
4-3-1	Peripheral Equipment Connection Examples	4-9
4-3-2	Selecting Connection Component	4-18

4-1 Installation Conditions

This section explains the conditions for installing Servo Drives, Servomotors and noise filters.

4-1-1 Servomotor Installation Conditions

Operating Environment Conditions

- The environment in which the Servomotor is operated must meet the following conditions. Operating the Servomotor outside of the following ranges may result in malfunction of the Servomotor.

Operating temperature: 0 to 40°C (The temperature at a point 50 mm from the Servomotor)

Operating humidity: 20% to 90% max. (with no condensation)

Operating ambient atmosphere: No corrosive gases.

Impact and Load

- The Servomotor is resistant to vibration of up to 49 m/s².
- If the Servomotor is mounted on a thin plate, the rigidity may decrease and severe vibration may occur.
- The Servomotor is resistant to impacts of up to 98 m/s². Do not apply heavy impacts or loads during transport, installation, or removal of the Servomotor.
- When transporting the Servomotor hold the motor body itself. And do not hold the encoder, cable, or connector areas. Failure to follow this guideline may result in damaging the Servomotor.
- Always use a pulley remover to remove pulleys, couplings, or other parts from the shaft.
- Connect cables and connectors carefully so that they are not strained. After assembly, secure cables so that there is no impact or load placed on the cable outlet.
- As a magnetic sensor is used for the encoder of the Servomotor, do not apply external magnetic force on the Servomotor (10 mT at the encoder cover surface).

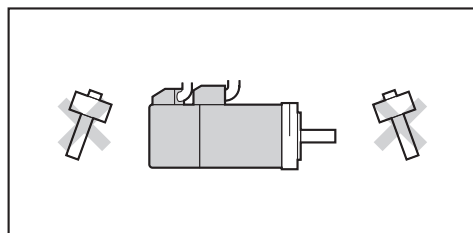

Connecting to Mechanical Systems

- For the allowable axial loads for Servomotors, refer to 3-2-3 *Characteristics* on page 3-12. If an axial load greater than that specified is applied to a Servomotor, it may reduce the limit of the motor bearings and may break the motor shaft.
- When you connect the Servomotor to a load, use couplings that can sufficiently absorb mechanical eccentricity and declination.
- When you connect or disconnect loads (or couplings) to or from the Servomotor, be careful not to apply an impact on the motor shaft. Do not allow the thrust load and radial load to exceed the values that are specified in the manual or catalog while you connect a load to the Servomotor.
- If an abnormal noise is generated from couplings, adjust the shaft center again to eliminate the noise.
- When you align the shaft center of the couplings, turn both the Servomotor side shaft and equipment side shaft.
- For spur gears, an extremely large radial load may be applied depending on the gear precision. Use spur gears with a high degree of precision (for example, JIS class 2: normal line pitch error of 6 μm max. for a pitch circle diameter of 50 mm).
- If the gear precision is not adequate, allow backlash to ensure that no radial load is placed on the motor shaft.
- When you use bevel gears, a load is applied in the thrust direction depending on the assembly precision, the gear precision, and temperature changes. Provide appropriate backlash or take other measures to ensure that a thrust load larger than the specified level is not applied.
- Do not put rubber packing on the flange surface. If the flange is mounted with rubber packing, the Servomotor flange may crack under the tightening force.
- When you connect the Servomotor to a V-belt or timing belt, consult the manufacturer for belt selection and tension.
- A radial load twice as large as the belt tension will be placed on the motor shaft. Do not allow a load that exceeds the allowable radial load to be placed on the motor shaft. If an excessive radial load is applied, the motor shaft and bearings may be damaged.

Set up a movable pulley in the middle of the motor shaft and the load shaft so that the belt tension can be adjusted.

Install the Servo Drive so that its bottom faces the gravity direction.

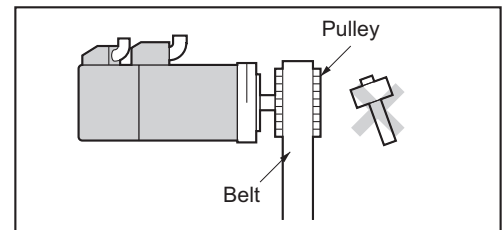
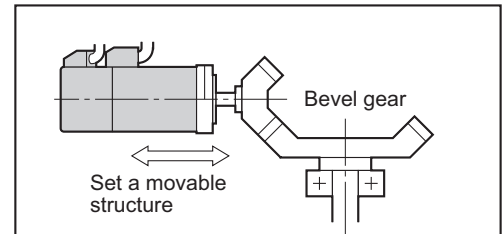
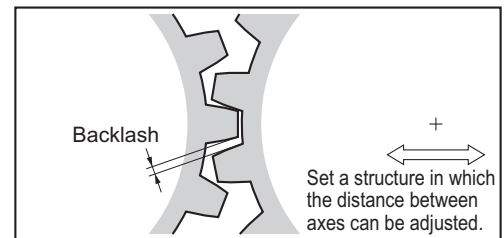
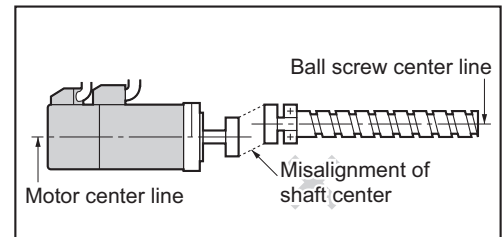
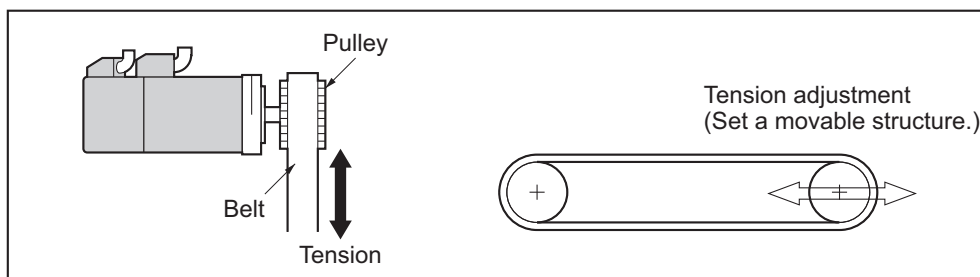

Water and Drip Resistance

The protective structure rating of the Servomotor is IP67, except for the through-shaft part and connector pins.

It is IP20 if you use a 30-meter or longer encoder cable.

Oil-water Measures

Do not use the Servomotors in an environment where oil drops can adhere to the through-shaft part.

Radiator Plate Installation Conditions

When you mount a Servomotor onto a small device, be sure to provide enough radiation space on the mounting area because the heat is radiated from the mounting surface. Otherwise the Servomotor temperature may rise too high. One of the preventive measures is to install a radiator plate between the motor attachment area and the motor flange. (See the following figure)

Failure to follow this guideline may result in damaging the Servomotor due to a temperature rise. Refer to 3-2 *Servomotor Specifications* on page 3-10 for the radiator plate specifications.

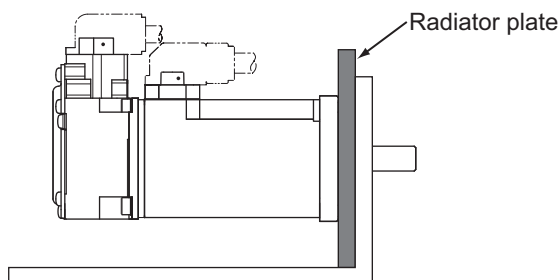

- The temperature rise depends on the mounting part materials and the installation environment. Check the actual temperature rise by using a real Servomotor.
- Depending on the environment, such as when the Servomotor is installed near a heating element, the Servomotor temperature may rise significantly. In this case, take any of the following measures.
 - a) Lower the load ratio.
 - b) Review the heat radiation conditions of the Servomotor.
 - c) Install a cooling fan and apply forced air cooling to the Servomotor.

Other Precautions

Take measures to protect the motor shaft from corrosion. The motor shaft is coated with anti-corrosion oil when it is shipped, but you should also apply anti-corrosion oil or grease when you connect the components that apply load to the shaft.



Caution



Do not apply a commercial power supply directly to the motor.
Fire may result.



Do not repair the Servo Drive by disassembling it.
Electric shock or injury may result.

4-2 Wiring

This section gives the examples of connection with peripheral equipment and wiring such as connection of the main circuit and Servomotor.

4-2-1 Connector Attachment Procedure

This section describes the procedure for attaching a connector to a Servomotor with a flange size of 80 x 80 or less. This example uses an encoder connector.

- 1 Align the connector's orientation with the key position, and fit the connector into place.

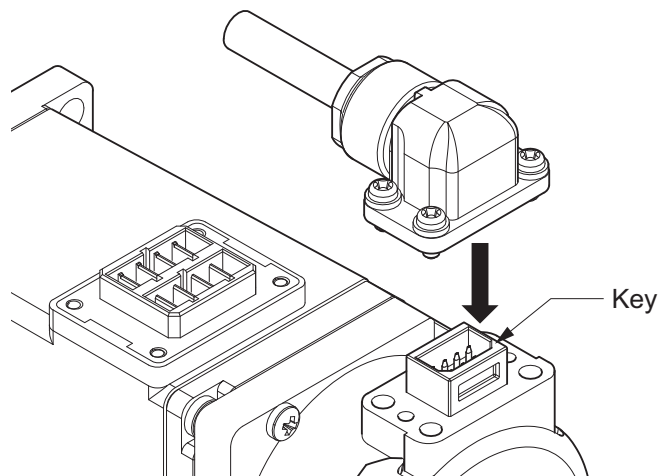

- 2 Tighten the screws to fix the connector after it is fitted.

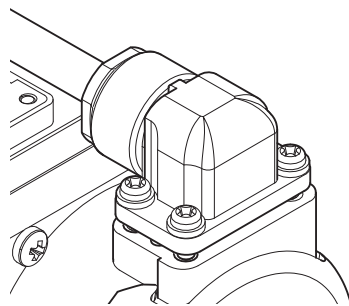

Example of a gap

Note Make sure that the connector is securely fitted into place without a gap or tilt.

Do not tighten the screws if the connector is not securely fitted into place. Doing so may result in a damage. Tighten the four screws evenly.

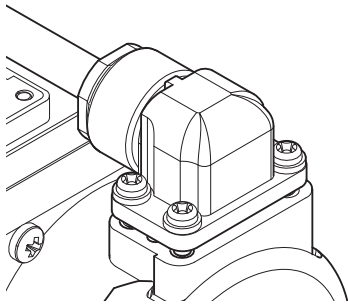

Example of a gap

Example: tighten the screws in the order of 1, 4, 3, and then 2.

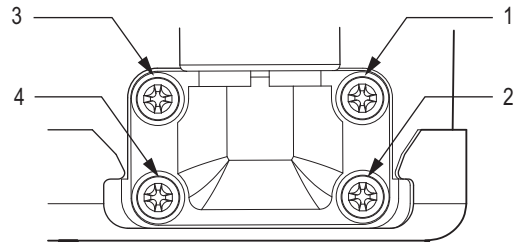

Example of screw tightening order

4-2-2 Power/Brake Connector Attachment Procedure

This section describes the procedure for attaching the Servomotor power/brake connector. Use the following procedure to fit the connectors.

1 Align of the main keys of the plug and receptacle.

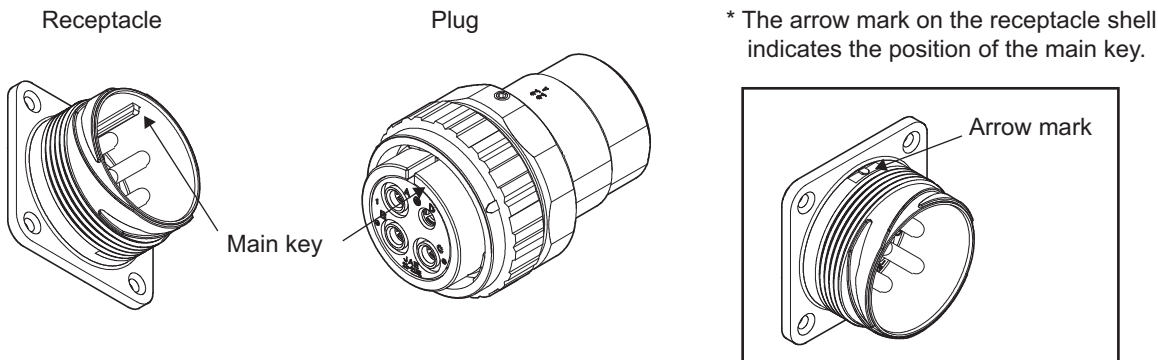

2 Press in the plug gently and turn the coupling nut clockwise.

Fitting is completed when the turned coupling nut clicks into place.

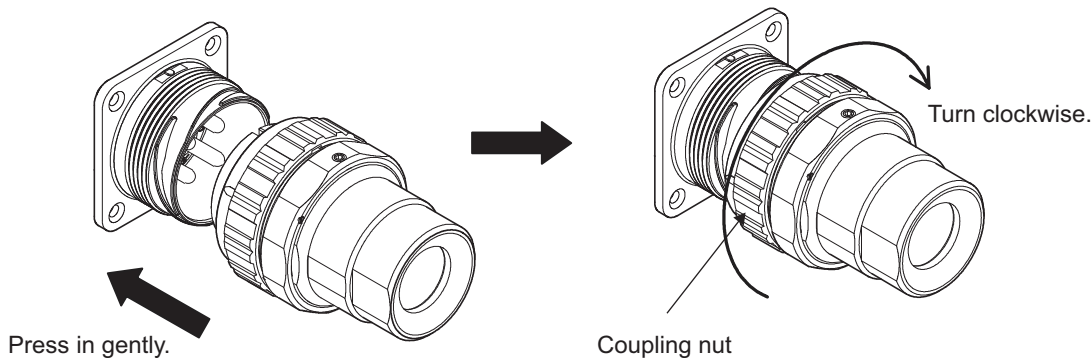

When fitting is completed, the arrow marks of the plug and receptacle are aligned.

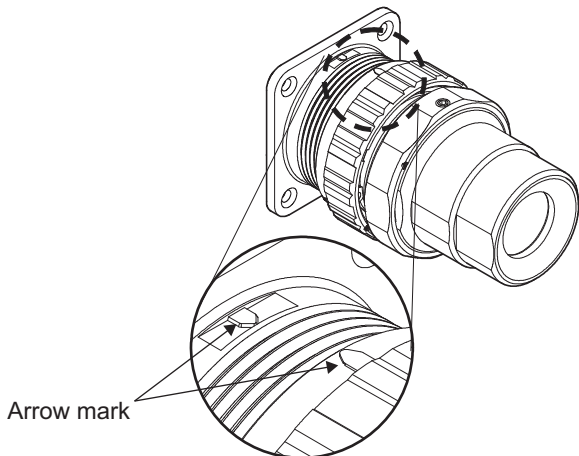

Note Before starting the fitting procedure, make sure that there is no dirt, foreign materials, etc. adhered to the fitting surfaces.

Do not perform the procedure in an environment where water or oil can adhere to these surfaces.

After fitting is completed, pull the plug gently (20 N max.) to confirm that it does not come out.

4-3 Wiring Conforming to EMC Directives

1S-series Servo Drives conform to the EMC Directives (EN 61800-3) under the wiring conditions described in this section.

The following conditions are determined so that 1S-series products can conform to EMC Directives. When the products are installed in the equipment, the customer must perform the check to confirm that the overall machine conforms to EMC Directives.

The following are the conditions required for conformance to the EMC Directives.

- Install the Servo Drive on the ground plate.
- Install a noise filter and lightening surge absorbing element (surge absorber) on the power line.
- Use braided-shield cables for the I/O signals and encoder. Tinned soft steel wires must be used for the shields.
- Ground the shield of each cable.

4-3-1 Peripheral Equipment Connection Examples

R88D-1SN01H-ECT/-1SN02H-ECT/-1SN04H-ECT/-1SN08H-ECT

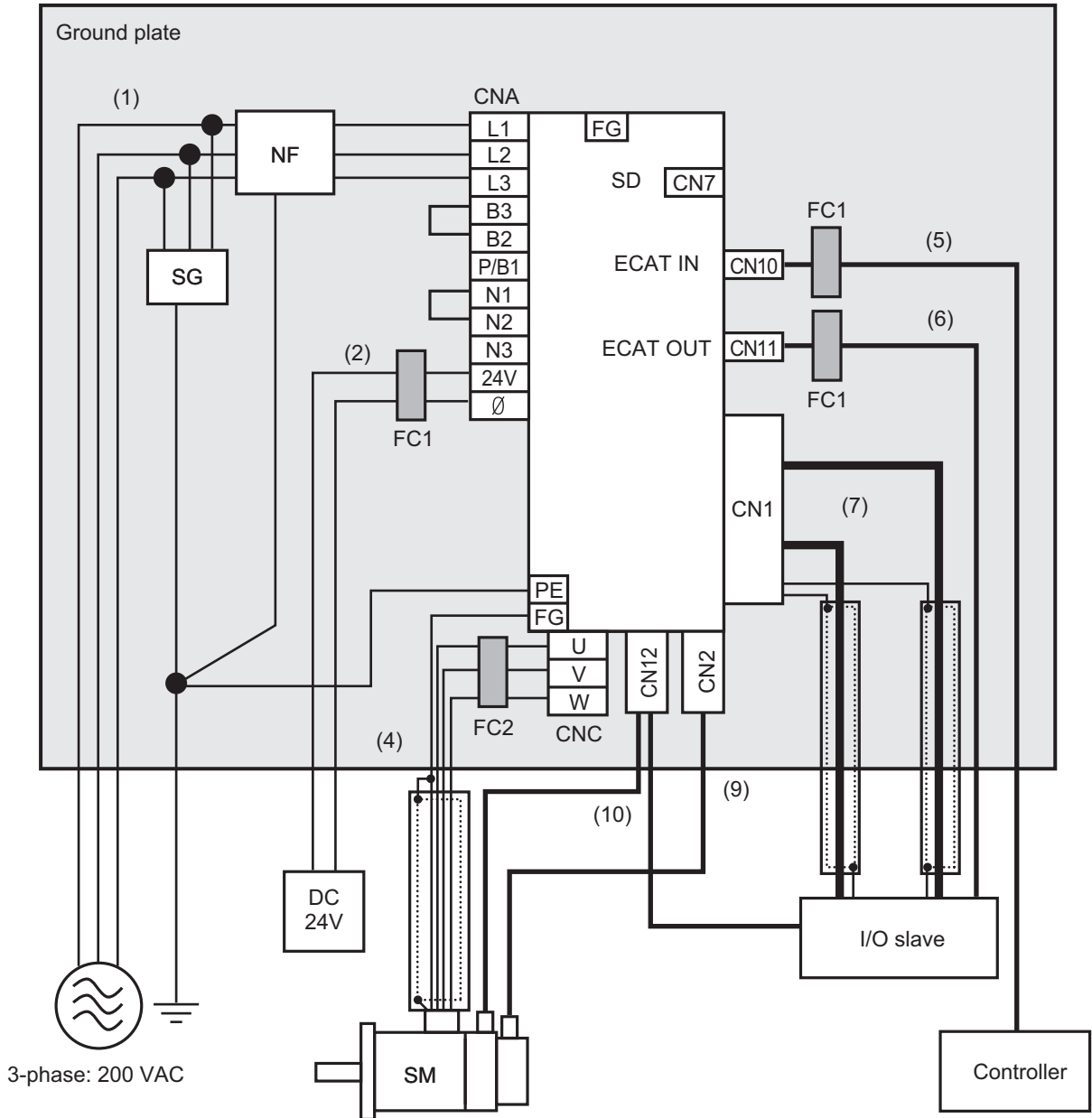

Note For single-phase inputs, connect between any two phases out of the following: L1, L2, and L3.

- Provide single-point grounding of the ground plate for unit frame grounding as shown in the above diagram.
- Use a protective earth wire with a minimum thickness of 2.5 mm² and arrange the wiring so that the protective earth wire is as short as possible.
- Install a surge absorber and noise filter near the main circuit connector A of Servo Drive. Separate I/O wires from each other for the wiring.

● Device Details

Symbol	Name	Manufacturer	Model	Remarks
SG	Surge absorber	Soshin Electric Co., Ltd.	LT-C32G801WS	3-phase 200 VAC
NF	Noise filter	Soshin Electric Co., Ltd.	HF3020C-SZC-33DDD *1	3-phase 200 VAC (20 A)
		OMRON	R88A-FI1S202	3-phase R88D-1SN01H-ECT
				3-phase R88D-1SN02H-ECT
			R88A-FI1S203	3-phase R88D-1SN04H-ECT
		R88A-FI1S208	3-phase R88D-1SN08H-ECT	
SD	Servo Drive	OMRON	---	*2
SM	Servomotor	OMRON	---	*2
FC1	Ferrite core	NEC TOKIN	ESD-SR-250	---
FC2	Ferrite core	SEIWA ELECTRIC MFG	E04SR301334	---
---	I/O slave	---	---	---
---	Controller	---	---	---

*1. Consult Soshin Electric Co., Ltd. for the specifications.

*2. Refer to 2-3-2 *Servo Drive and Servomotor Combination Tables* on page 2-6 for Servo Drive and Servomotor combinations.

● Cable Details

No.	Interface	Max. cable length, shield	Cable classification		Ferrite core
			EN/IEC 61800-3	EN/IEC 61326-3-1	
1	Power supply cable (main circuit)	3 m Non-shielded	Power supply port	AC input power supply port	None
2	Power supply cable (control circuit)	3 m Non-shielded	Port for process measurement and control	Signal and control line	2 turns
4	Motor cable (Servomotor)	20 m Shielded	Power supply interface	Signal and control line	2 turns
5	EtherCAT communications cable (ECAT IN)	20 m Shielded	Signal interface	Signal and control line	1 turn
6	EtherCAT communications cable (ECAT OUT)	20 m Shielded	Signal interface	Signal and control line	1 turn
7	Safety/control I/O cables	20 m Shielded	Signal interface	Signal and control line	None
		20 m Shielded	Signal interface	Signal and control line	None
9	Encoder cable	20 m Shielded	Signal interface	Signal and control line	None
10	Brake interlock cable	20 m Non-shielded	Signal interface	Signal and control line	None

R88D-1SN10H-ECT

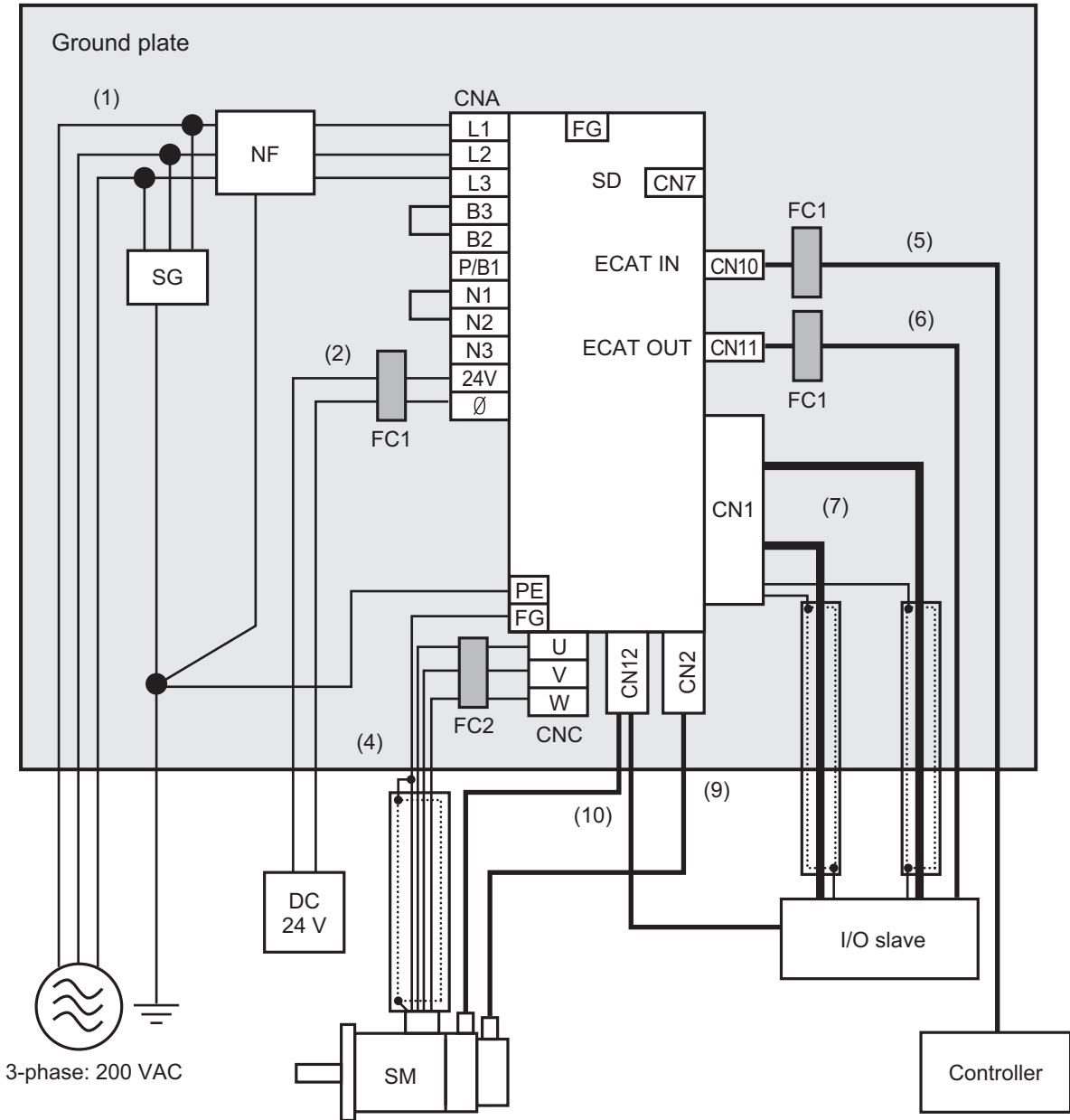

- Provide single-point grounding of the ground plate for unit frame grounding as shown in the above diagram.
- Use a protective earth wire with a minimum thickness of 2.5 mm² and arrange the wiring so that the protective earth wire is as short as possible.
- Install a surge absorber and noise filter near the main circuit connector of Servo Drive. Separate I/O wires from each other for the wiring.

● Device Details

Symbol	Name	Manufacturer	Model	Remarks
SG	Surge absorber	Soshin Electric Co., Ltd.	LT-C32G801WS	3-phase 200 VAC
NF	Noise filter	Soshin Electric Co., Ltd.	HF3020C-SZC-33DDD *1	3-phase 200 VAC (20 A)
		OMRON	R88A-F1S208	3-phase R88D-1SN10H-ECT
SD	Servo Drive	OMRON	R88D-1SN10H-ECT	*2
SM	Servomotor	OMRON	---	*2
FC1	Ferrite core	NEC TOKIN	ESD-SR-250	---
FC2	Ferrite core	SEIWA ELECTRIC MFG	E04SR301334	---
---	I/O slave	---	---	---
---	Controller	---	---	---

*1. Consult Soshin Electric Co., Ltd. for the specifications.

*2. Refer to 2-3-2 *Servo Drive and Servomotor Combination Tables* on page 2-6 for Servo Drive and Servomotor combinations.

● Cable Details

No.	Interface	Max. cable length, shield	Cable classification		Ferrite core
			EN/IEC 61800-3	EN/IEC 61326-3-1	
1	Power supply cable (main circuit)	3 m Non-shielded	Power supply port	AC input power supply port	None
2	Power supply cable (control circuit)	3 m Non-shielded	Port for process measurement and control	Signal and control line	2 turns
4	Motor cable (Servomotor)	20 m Shielded	Power supply interface	Signal and control line	2 turns
5	EtherCAT communications cable (ECAT IN)	20 m Shielded	Signal interface	Signal and control line	1 turn
6	EtherCAT communications cable (ECAT OUT)	20 m Shielded	Signal interface	Signal and control line	1 turn
7	Safety/control I/O cables	20 m Shielded	Signal interface	Signal and control line	None
		20 m Shielded	Signal interface	Signal and control line	None
9	Encoder cable	20 m Shielded	Signal interface	Signal and control line	None
10	Brake Interlock cable	20 m Shielded	Signal interface	Signal and control line	None

R88D-1SN15H-ECT

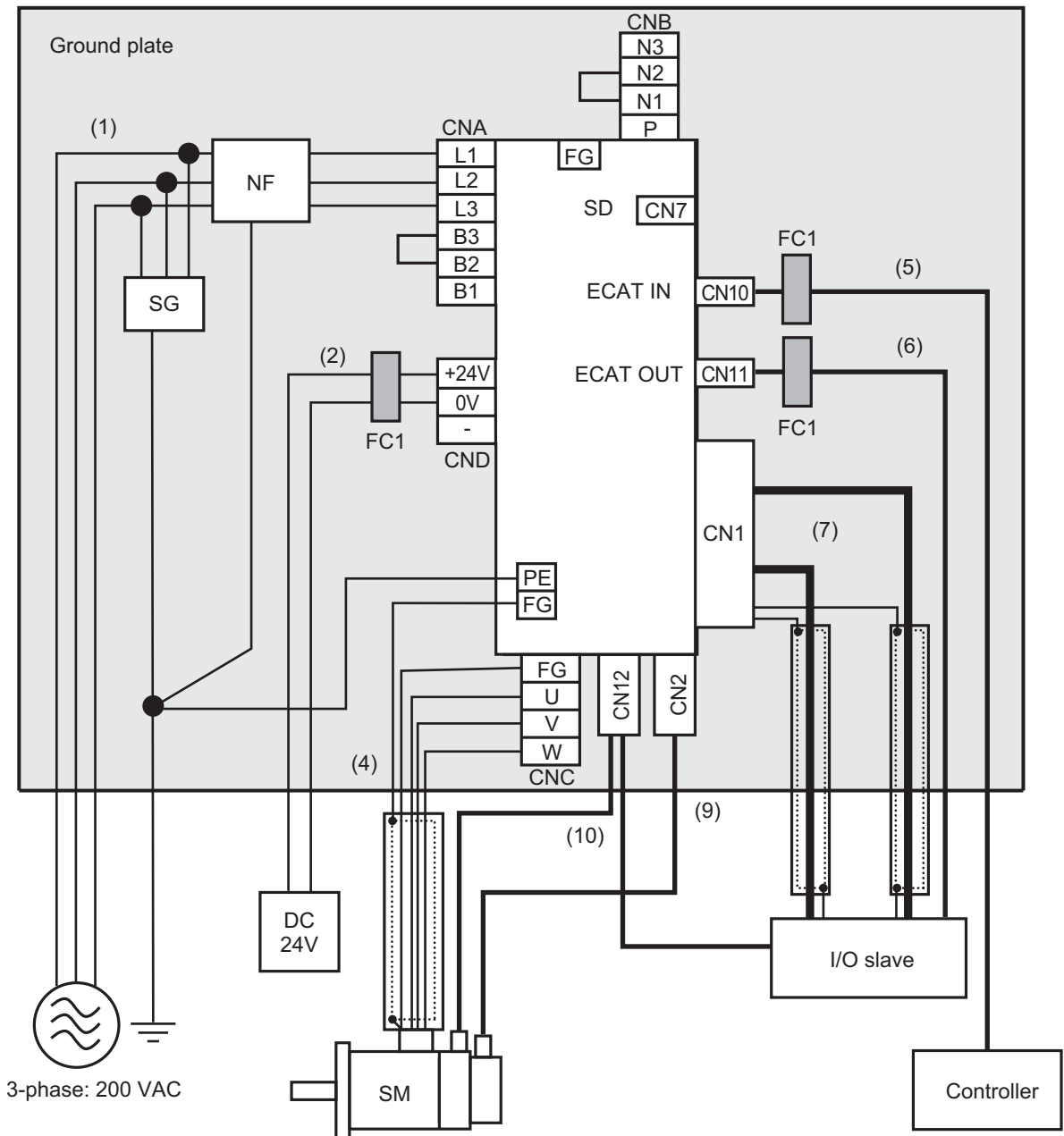

Note For single-phase inputs, connect between any two phases out of the following: L1, L2, and L3.

- Provide single-point grounding of the ground plate for unit frame grounding as shown in the above diagram.
- Use a protective earth wire with a minimum thickness of 2.5 mm² and arrange the wiring so that the protective earth wire is as short as possible.
- Install a surge absorber and noise filter near the main circuit connector A of Servo Drive. Separate I/O wires from each other for the wiring.

● Device Details

Symbol	Name	Manufacturer	Model	Remarks
SG	Surge absorber	Soshin Electric Co., Ltd.	LT-C32G801WS	3-phase 200 VAC
NF	Noise filter	Soshin Electric Co., Ltd.	HF3020C-SZC-33DDD *1	3-phase 200 VAC (20 A)
		OMRON	R88A-F11S216	3-phase R88D-1SN15H-ECT
				3-phase R88D-1SN20H-ECT
				3-phase R88D-1SN30H-ECT
SD	Servo Drive	OMRON	---	*2
SM	Servomotor	OMRON	---	*2
FC1	Ferrite core	NEC TOKIN	ESD-SR-250	---
---	I/O slave	---	---	---
---	Controller	---	---	---

*1. Consult Soshin Electric Co., Ltd. for the specifications.

*2. Refer to 2-3-2 *Servo Drive and Servomotor Combination Tables* on page 2-6 for Servo Drive and Servomotor combinations.

● Cable Details

No.	Interface	Max. cable length, shield	Cable classification		Ferrite core
			EN/IEC 61800-3	EN/IEC 61326-3-1	
1	Power supply cable (main circuit)	3 m Non-shielded	Power supply port	AC input power supply port	None
2	Power supply cable (control circuit)	3 m Non-shielded	Port for process measurement and control	Signal and control line	2 turns
4	Motor cable (Servomotor)	20 m Shielded	Power supply interface	Signal and control line	None
5	EtherCAT communications cable (ECAT IN)	20 m Shielded	Signal interface	Signal and control line	1 turn
6	EtherCAT communications cable (ECAT OUT)	20 m Shielded	Signal interface	Signal and control line	1 turn
7	Safety/control I/O cables	20 m Shielded	Signal interface	Signal and control line	None
		20 m Shielded	Signal interface	Signal and control line	None
9	Encoder cable	20 m Shielded	Signal interface	Signal and control line	None
10	Brake Interlock cable	20 m Shielded	Signal interface	Signal and control line	None

Noise Filter for Power Input

The following noise filters are recommended for Servo Drives.

The noise filter comes in two types: book type and footprint type. Both types conform to the EMC Directives.

Applicable Servo Drive		Book-type Noise Filter ^{*1}			
Phase	Model	Model	Rated current	Leakage current	Manufacturer
Single-phase	R88D-1SN□□□-E CT	HF2020A-SZC-33 DDD	20 Arms	8.5 mA max. (at 250 VAC 60 Hz)	Soshin Electric Co., Ltd.
3-phase	R88D-1SN□□H-E CT	HF3020C-SZC-33 DDD	20 Arms	3.5 mA max. (at 400 VAC 50 Hz by UL1283 ^{*2}), 4.0 mA max. (at 200 VAC 60 Hz, delta connection and single-phase ground)	

*1. Consult Soshin Electric Co., Ltd. for the specifications.

*2. When you use a neutral grounded 3-phase power supply, the leakage current does not flow normally.

Applicable Servo Drive			Footprint-type Noise Filter			
Phase	Voltage	Model	Model	Rated current	Leakage current	Manufacturer
Single-phase	200 V	R88D-1SN01H-ECT	R88A-FI1S103	3 Arms	6.6 mA (at 200 VAC 60Hz)	OMRON
		R88D-1SN02H-ECT		5 Arms		
		R88D-1SN04H-ECT	R88A-FI1S105	9 Arms		
		R88D-1SN08H-ECT	R88A-FI1S109	16 Arms		
		R88D-1SN15H-ECT	R88A-FI1S116			
3-phase	200 V	R88D-1SN01H-ECT	R88A-FI1S202 ^{*1}	2 Arms	35 mA (at 200 VAC 60Hz, with delta connec- tion and single phase ground)	
		R88D-1SN02H-ECT				
		R88D-1SN01H-ECT	R88A-FI1S203 ^{*1}	3 Arms	14 mA (at 200 VAC 60Hz, with delta connec- tion and single phase ground)	
		R88D-1SN02H-ECT				
		R88D-1SN04H-ECT				
		R88D-1SN08H-ECT	R88A-FI1S208	8 Arms		
		R88D-1SN10H-ECT	R88A-FI1S216	16 Arms		
R88D-1SN15H-ECT						

*1. Select a Noise Filter in accordance with the amount of the leakage current. If there is no problem with the amount of the leakage current, you can select the R88A-FI1S202.

- If the molded case circuit breaker is located in an upper area and the power supply is wired through the duct at the bottom, keep a sufficient distance between the input wires and internal wires, or use the metal tubing for wiring. If input and output cables are placed in the same duct, the noise immunity will be impaired.
- Place the noise filter as close as possible to the opening of the control panel. Use the diagram below to the left for wiring.

○ Separate I/O

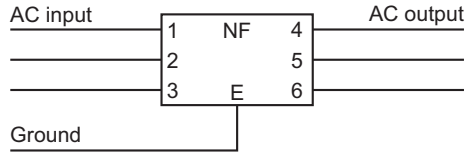

✗ Noise filter less effective

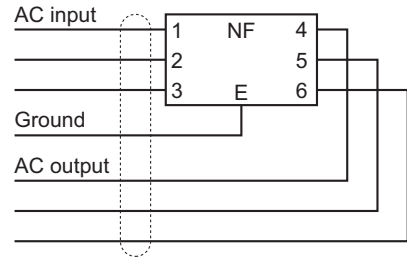

- The power cables must be twisted or tightly bundled.

○ Twist

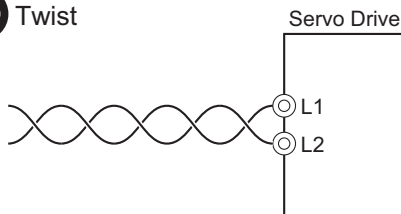

○ Tight bundle

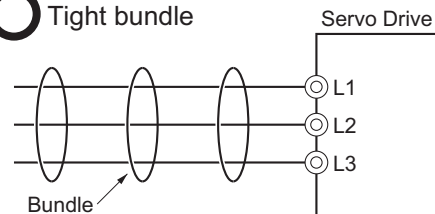

- Wire the power and signal lines separately.

● External Dimensions of Book-type Noise Filter

HF2020A-SZC-33DDD/HF3020C-SZC (-33DDD)

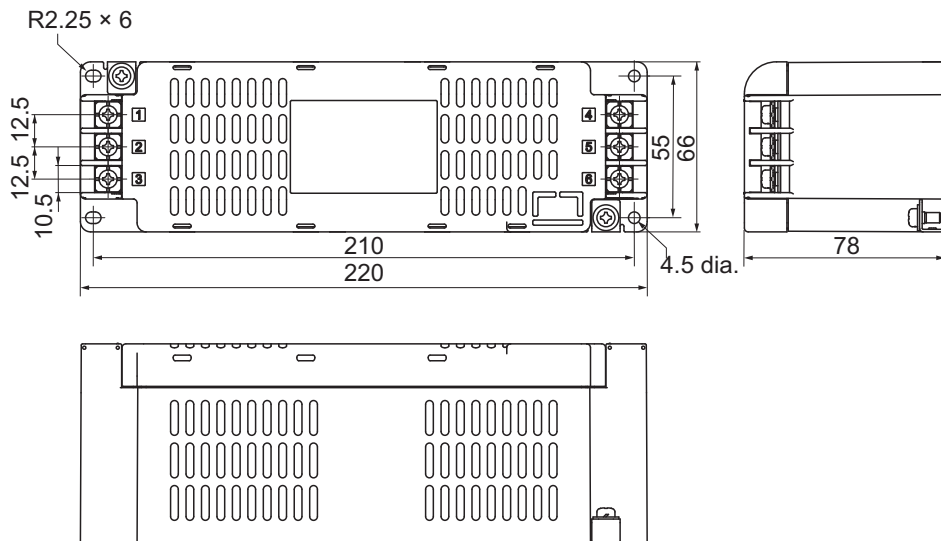

● **Circuit Diagram of Book-type Noise Filter**

HF2020A-SZC-33DDD

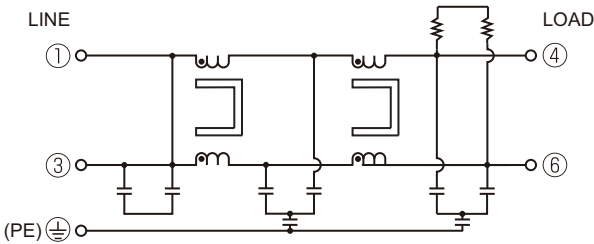

HF3020C-SZC-33DDD

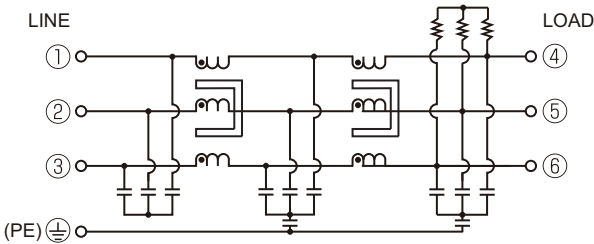

4-3-2 Selecting Connection Component

This section describes the criteria for selecting connection components that are required to improve noise immunity.

Thoroughly understand the characteristics such as capacity, performance, and the range of application of the connection components before you select them.

Consult the manufacturer for details of the parts.

Molded Case Circuit Breaker (MCCB)

Select a molded case circuit breaker based on the maximum input current and inrush current.

● Maximum input current

- The momentary maximum output of the Servo Drive is approximately three times as much as the rated output, and the maximum output duration is three seconds. Therefore, select a molded case circuit breaker which can operate 10 seconds or more at 300% of the rated current.
- Select a molded case circuit breaker with a rated current larger than the sum of the effective load current (when multiple Servo Drives are used). Refer to *Main Circuit and Motor Connections* on page 3-4 for the rated current of the power supply input for each motor.
- When you select a molded case circuit breaker, add the current consumption by other devices such as the Controller.

● Inrush Current

- The following table shows the inrush current of the Servo Drives.
- The amount of inrush current that a low-speed type molded case circuit breaker can flow for 0.02 seconds is approximately 10 times higher than the rated current.
- To turn ON the power supply for multiple Servo Drives simultaneously, select a molded case circuit breaker whose allowable current in 20 ms is larger than the sum of the inrush currents shown in the following table.
- The inrush current of the control power supply is limited by the output capacity of the DC power supply in use.

Servo Drive model	Inrush current (Ao-p)
	Main circuit power supply
R88D-1SN01H-ECT	16 A ^{*1}
R88D-1SN02H-ECT	16 A ^{*1}
R88D-1SN04H-ECT	16 A ^{*1}
R88D-1SN08H-ECT	16 A ^{*1}
R88D-1SN10H-ECT	16 A ^{*1}
R88D-1SN15H-ECT	29 A

*1. If an external regeneration resistor is attached, the inrush currents of the main circuit power supplies in the above table will be increased.

(Increase in current = $\sqrt{2} \times$ main circuit power supply voltage/external regeneration resistance)

The value of the inrush current varies depending on the input voltage to the Servo Drive. The values shown above are for the following input voltages.

Model	Main circuit power supply voltage
R88D-1SN□H-ECT	240 VAC

Leakage Breaker

- Select a leakage breaker which is made for high frequency and surge resistance.
- When you determine the threshold value for leakage current detection, add the total leakage current from all devices that are connected to the same breaker.
- Refer to the catalogs from the manufacturers for details on how to select a leakage breaker and ensure a sufficient margin.

Servo Drive model (R88D-)	Servomotor model (R88D-)	Input power	Leakage current (3 m cable)	Increase per 10 m of cable length
1SN01H-ECT	1M10030H	Single-phase 200 V	1.5 mA	1.3 mA
		3-phase 200 V		
1SN02H-ECT	1M20030H	Single-phase 200 V	1.5 mA	1.3 mA
		3-phase 200 V		
1SN04H-ECT	1M40030H	Single-phase 200 V	1.5 mA	1.3 mA
		3-phase 200 V		
1SN08H-ECT	1M75030H	Single-phase 200 V	1.5 mA	1.3 mA
		3-phase 200 V		
1SN10H-ECT	1L1K030H	3-phase 200 V	1.5 mA	1.3 mA
	1M1K020H	3-phase 200 V		
1SN15H-ECT	1L1K530H	Single-phase 200 V	2.2 mA	1.9 mA
		3-phase 200 V		
	1M1K520H	Single-phase 200 V		
		3-phase 200 V		

Note These values vary greatly depending of the installation conditions of the motor power cable and the measurement conditions. Use the values just as a reference.

Surge Absorber

- Use a surge absorber to absorb the lightning surge voltage and the abnormal voltage from the power input line.
- The following table gives the recommended surge absorber specifications.

Servo Drive voltage	Surge current tolerance	Recommended manufacturer	Recommended model
Single-phase 200 VAC	410 V±20%, 2500 A	Soshin Electric Co., Ltd.	LT-C12G801WS
3-phase 200 VAC	410 V±20%, 2500 A	Soshin Electric Co., Ltd.	LT-C32G801WS

- Note
1. Refer to the catalogs from the manufacturer for how to use.
 2. The surge current tolerance is the value for the standard impulse current of 8/20 μ s. For a greater pulse width, reduce the current or change the surge absorber to the one with a higher capacity.
 3. Select a CSA-certified product when you use a surge absorber.

● External Dimensions

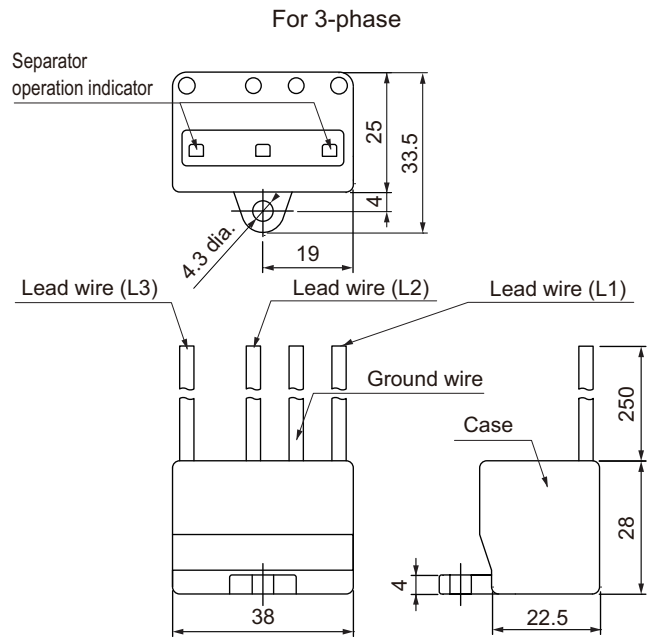
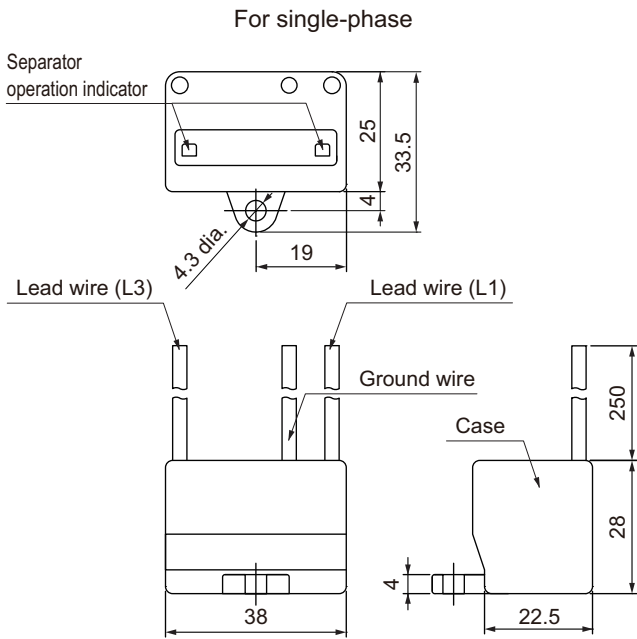

● Equivalent Circuit

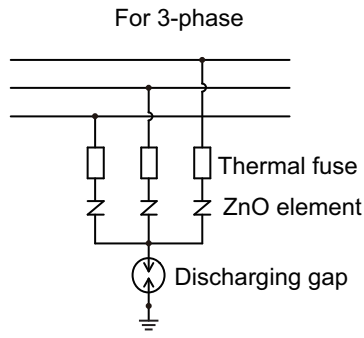
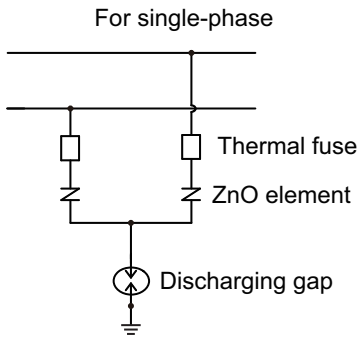

Surge Suppressors

- Install surge suppressors for a load with an induction coil such as a relay, solenoid, and clutch.
- The following table gives the types of surge suppressors and the recommended products.

Type	Feature	Recommended product
Diode	Diodes are used for relatively small loads such as relays when the reset time is not an issue. The surge voltage at power cutoff is the lowest, but the reset time takes longer. Used for 24/48-VDC systems.	Use a high-speed diode, especially the fast-recovery diode with short reverse recovery time such as RU2 made by San-ken Electronic Co., Ltd.
Varistor	Thyristors and varistors are used for loads when an induction coil is large, as in a solenoid, and when reset time is an issue. The surge voltage at power cutoff is approximately 1.5 times the varistor voltage.	Select the varistor voltage according to the following list. <ul style="list-style-type: none"> • 24-VDC type: varistor voltage 39 V • 100-VDC type: varistor voltage 200 V • 100-VAC type: varistor voltage 270 V • 200-VAC type: varistor voltage 470 V
Capacitor and resistor	The combination of capacitor and resistor is used to absorb vibration in the surge at power cutoff. You can shorten the reset time by selecting the appropriate capacitance and resistance.	Okaya Electric Industries Co., Ltd. XEB12002 0.2 μ F - 120 Ω XEB12003 0.3 μ F - 120 Ω

- The manufacturer of varistor is shown below. Refer to the catalogs from the manufacturer for details.
Varistor: SEMITEC Corporation, Panasonic Corporation

Contactors

Select a contactor based on the inrush current that flows through circuits and the maximum momentary phase current.

For details on the inrush current of the Servo Drives, refer to *Molded Case Circuit Breaker (MCCB)* on page 4-18.

Improving Noise Immunity of Control I/O Signals

The I/O signals may malfunction if control I/O is affected by noise.

- Use the control I/O power supply (especially 24 VDC) which is completely separated from the external power supply used for operation. Especially, be careful not to connect the ground wires of these two power supplies.
- Install a noise filter on the primary side of the control I/O power supply.
- When you use a motor with a brake, do not share the 24 VDC power supply between the brake and the control I/O (24 VDC). Also, do not connect the ground wires. Doing so may cause I/O signals to malfunction.
- If there is a long wiring for the control I/O power supply, you can improve its noise immunity by adding an approximately 1- μ F laminated ceramic capacitor between the control I/O power supply and the ground at the Servo Drive's input section or the Controller's output section.

Reactor for Harmonic Current Reduction

● Countermeasure against Harmonic Current

- Use a reactor to suppress the harmonic current. A reactor can suppress a sharp change in current.
- Select the reactor according to the model of your Servo Drive.

Applicable Servo Drive		DC Reactor		
Voltage	Model	Model	Rated current	Inductance (0% to 20%)
200 VAC	R88D-1SN01H-ECT	R88A-PD2002	1.6 A	21.4 mH
	R88D-1SN02H-ECT			
	R88D-1SN04H-ECT	R88A-PD2004	3.2 A	10.7 mH
	R88D-1SN08H-ECT	R88A-PD2007	6.1 A	6.75 mH
	R88D-1SN10H-ECT	R88A-PD2015	9.3 A	3.51 mH
	R88D-1SN15H-ECT			

● DC Reactor Connection

As shown in the following figure, remove the short-circuit wire between N1 and N2, and connect the DC Reactor between N1 and N2.

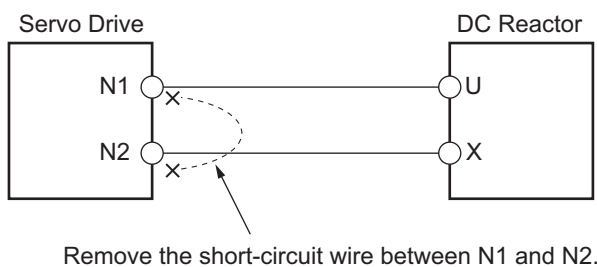

5

Details on Servo Parameters

This section explains the details on Servomotor-related parameters, including the set values, settings, and the display.

For the details on Servo Drive-related parameters, refer to the *AC Servomotors/Servo Drives 1S-series with Built-in EtherCAT® Communications User's Manual (I586)*.

5-1	Object Description Format	5-2
5-2	External Device-related Objects	5-4
5-3	Encoder-related Objects	5-6

5-1 Object Description Format

The 1S-series Servo Drives with built-in EtherCAT communications use the servo parameters that are defined with objects. For information on the objects, refer to *1-1-3 Object Dictionary* on page 1-4.

In this manual, objects are described in the following format.

Index (hex)	Subindex (hex)	Object name	Setting range	Unit	Default setting	Data attribute	Size	Access	PDO map	Complete access	Modes of operation
<Index>	<Subindex>	<Object name>	<Range>	<Unit>	<Default>	<Attribute>	<Size>	<Access>	<PDO map>	<Complete access>	<Modes of operation>

Data is indicated in pointed brackets <>. Details on data are as follows.

Item	Description
Index	Object index given by a four-digit hexadecimal number.
Subindex	Object subindex given by a two-digit hexadecimal number.
Object name	The object name. For a subindex, the subindex name is given.
Setting range	Indicates the range of data that can be set for a writable object.
Unit	Physical units.
Default setting	Default value set before shipment.
Data attribute	The timing when a change in the contents is updated for a writable object. A: Always updated D: Possible to change only when the EtherCAT communications state is Pre-Operational (Pre-Op) E: Servo ON R: Updated after the control power is reset or restarted –: Write prohibited
Size	Gives the object size.
Access	Indicates whether the object is to read only, or read and write. RO: Read only RW: Read and write (Saved in non-volatile memory) W: Read and write (Not saved in non-volatile memory)
PDO map	Indicates the PDO mapping attribute. RxPDO: Reception PDOs can be mapped TxPDO: Transmission PDOs can be mapped –: PDOs cannot be mapped
Complete access	Indicates whether Complete access is allowed or not.
Modes of operation	The profile mode in which the object is enabled. –: Independent of the Modes of operation csp: Cyclic synchronous position mode csv: Cyclic synchronous velocity mode cst: Cyclic synchronous torque mode pp: Profile position mode pv: Profile velocity mode hm: Homing mode

Mirror Objects

For 1S-series Servo Drives, a special object called “mirror object” is defined.

A mirror object enables access to the same object from different object numbers. Accessing the mirror object and accessing the original object cause the same operation.

More specifically, the mirror objects are used to assign the Servo Drive profile objects (index number 6000s) to the servo parameter objects (index number 3000s to 4000s).

5-2 External Device-related Objects

These objects are used for the motor information display.

Index (hex)	Sub-index (hex)	Object name	Setting range	Unit	Default setting	Data attribute	Size	Access	PDO map	Complete access	Modes of operation
4410	---	Motor Identity	---	---	---	---	---	---	---	Possible	---
	00	Number of entries	---	---	FF hex	---	1 byte (U8)	RO	---	---	---
	81	Motor Model	---	---	---	---	20 bytes (VS)	RO	---	---	---
	82	Serial Number	---	---	---	---	16 bytes (VS)	RO	---	---	---
	83	Last Connected Motor Model	---	---	---	---	20 bytes (VS)	RO	---	---	---
	84	Last Connected Serial Number	---	---	---	---	16 bytes (VS)	RO	---	---	---
	90	Motor Type	---	---	---	---	2 bytes (U16)	RO	---	---	---
	92	Motor Manufacturer	---	---	---	---	20 bytes (VS)	RO	---	---	---
	F1	Motor Setup	---	---	0	A	4 bytes (INT32)	W	---	---	---
	FF	Setup Status	---	---	---	---	4 bytes (INT32)	RO	---	---	---

Subindex 81 hex: Motor Model

- Gives the model of the motor which is connected to the Servo Drive.

Subindex 82 hex: Serial Number

- Gives the serial number of the motor which is connected to the Servo Drive.

Subindex 83 hex: Last Connected Motor Model

- Gives the model of the motor which was connected the last time.

Subindex 84 hex: Last Connected Serial Number

- Gives the serial number of the motor which was connected the last time.

Subindex 90 hex: Motor Type

- Gives the type of connected motor.
- Mirror object of 6402 hex

Subindex 92 hex: Motor Manufacturer

- Gives the motor manufacturer name.
- Mirror object of 6404 hex

Subindex F1 hex: Motor Setup

- The Motor ID Setup is executed by the writing of 7465 736D hex.

Subindex FF hex: Setup Status

- Gives the execution status of Motor Setup.

● Description of Set Values

Set value	Description
0	Setup is not executed or completed
1	Setup in execution

5-3 Encoder-related Objects

These objects are used for the encoder setting.

Index (hex)	Sub-index (hex)	Object name	Setting range	Unit	Default setting	Data attribute	Size	Access	PDO map	Complete access	Modes of operation
4510	---	Encoder	---	---	---	---	---	---	---	Possible	---
	00	Number of entries	---	---	FF hex	---	1 byte (U8)	RO	---	---	---
	01	Operation Selection when Using Absolute Encoder	0 to 2	---	2	R	4 bytes (INT32)	RW	---	---	---
	02	Absolute Encoder Counter Overflow Warning Level	0 to 32,767	rotation	32,000	A	4 bytes (INT32)	RW	---	---	---
	81	Serial Number	---	---	---	---	16 bytes (VS)	RO	---	---	---
	82	Resolution per Rotation	---	---	---	---	4 bytes (INT32)	RO	---	---	---
	84	One-rotation Data	---	Encoder unit	---	---	4 bytes (U32)	RO	---	---	---
	85	Multi-rotation Data	---	rotation	---	---	4 bytes (INT32)	RO	---	---	---
	86	Encoder Communications Error Count	---	---	---	---	4 bytes (INT32)	RO	---	---	---
	87	Electric Angle	---	°	---	---	4 bytes (INT32)	RO	---	---	---
	88	Mechanical Angle	---	°	---	---	4 bytes (U32)	RO	---	---	---
	89	Encoder Temperature	---	°C	---	---	4 bytes (INT32)	RO	---	---	---
	F1	Absolute Encoder Setup	00000000 to FFFFFFFF hex	---	0	A	4 bytes (U32)	W	---	---	---
	F2	Encoder Communications Error Count Clear	00000000 to FFFFFFFF hex	---	0	A	4 bytes (U32)	W	---	---	---
	FF	Clear Status	---	---	---	---	4 bytes (U32)	RO	---	---	---

Subindex 01 hex: Operation Selection when Using Absolute Encoder

- Selects the operating method for the absolute encoder.

● Description of Set Values

- When you use the Incremental Encoder Type Servomotors, you do not need to set this object.

Set value	Description
0	Use as the absolute encoder
1	Use as the incremental encoder
2	Used as the absolute encoder and ignore the absolute encoder counter overflow.

Subindex 02 hex: Absolute Encoder Counter Overflow Warning Level

- Sets the level to notify the warning.
- When the **Operation Selection when Using Absolute Encoder** is set to 0 (use as the absolute encoder), if the absolute value of encoder multi-rotation number exceeds the set value, the Absolute Encoder Counter Overflow Warning is output.

Subindex 81 hex: Serial Number

- Gives the encoder serial number.

Subindex 82 hex: Resolution per Rotation

- Gives the resolution per rotation.

Subindex 84 hex: One-rotation Data

- Gives the one-rotation position of the encoder. When the phase-Z position is 0, if the motor rotates counterclockwise as viewed from the motor load side, the encoder value increases.

Subindex 85 hex: Multi-rotation Data

- Gives the number of encoder rotations. The encoder value increases each time the motor rotates counterclockwise as viewed from the motor load side.
- When you use the Incremental Encoder Type Servomotors, the encoder value is always set to 0.

Subindex 86 hex: Encoder Communications Error Count

- Obtains the total number of encoder errors via serial communications.

Subindex 87 hex: Electric Angle

- Gives the electric angle.
- In the counterclockwise rotation, 0° indicates the position which is the zero cross point (rising) of the phase-U inductive voltage.
- The encoder value increases when the motor rotates counterclockwise, and the display range is from 0 to 359°.

Subindex 88 hex: Mechanical Angle

- Gives the one-rotation data of the encoder as the mechanical angle.
- The encoder value increases when the motor rotates counterclockwise, and the display range is from 0 to 359°.

Subindex 89 hex: Encoder Temperature

- Gives the internal temperature of the encoder which is mounted on the motor, or the internal temperature of the motor.

Subindex F1 hex: Absolute Encoder Setup

- Clears the multi-rotation counter of the absolute encoder. Clear is executed by the writing of *6A646165 hex* to this object.
- When you use the Incremental Encoder Type Servomotors, clear is not executed.

Subindex F2 hex: Encoder Communications Error Count Clear

- Clears the Encoder Communications Error Count. Clear is executed by the writing of *1* to this object.

Subindex FF hex: Clear Status

- Gives the status of the multi-rotation counter of the absolute encoder and Encoder Communications Error Count Clear.

● Description of Set Values

Set value	Description
Bit 0	Status of Absolute Encoder Setup
0	Clear is not executed or completed
1	Clear in execution
Bit 1	Status of Encoder Communications Error Count Clear
0	Clear is not executed or completed
1	Clear in execution



Operation

This section provides the operational procedure and explains how to operate in each mode.

6-1	Operational Procedure	6-2
6-2	Preparing for Operation	6-3
6-2-1	Items to Check Before Turning ON the Power Supply	6-3
6-2-2	Turning ON the Power Supply	6-4
6-2-3	Checking the Displays	6-5
6-3	Test Run	6-7
6-3-1	Preparations for Test Run	6-7
6-3-2	Test Run via USB Communications from the Sysmac Studio	6-8

6-1 Operational Procedure

Perform installation and wiring correctly, and turn ON the power supply to check the operation of the individual Servomotor and Servo Drive.

Then make the function settings as required according to the use of the Servomotor and Servo Drive.

If the objects are set incorrectly, there is a risk of unexpected motor operation, which can be dangerous. Set the objects accurately according to the setting methods in this manual.

Item	Description	Reference
Installation and mounting	Install the Servomotor and Servo Drive according to the installation conditions. Do not connect the Servomotor to mechanical systems before checking the operation without any load.	Section 4, 4-1
↓		
Wiring and connections	Connect the Servomotor and Servo Drive to the power supply and peripheral equipment. Satisfy specified installation and wiring conditions, particularly for models that conforms to the EU Directives.	Section 4, 4-2
↓		
Preparing for operation	Check the necessary items and then turn ON the commercial power supply. Check on the display to see whether there are any internal errors in the Servo Drive.	Section 6, 6-2
↓		
Function settings	Set the objects related to the functions required for application conditions.	Section 5
↓		
Test run	First, check motor operation without any load. Then turn the power supply OFF and connect the Servomotor to mechanical systems. Execute the Unit Restart or cycle the power supply, and check to see whether protective functions, such as the immediate stop and operational limits, operate properly. Check operation at both low speed and high speed using the system without a workpiece, or with dummy workpieces.	Section 6, 6-3
↓		
Adjustment	Manually adjust the set values of objects such as gain if necessary.	I586
↓		
Operation	Operation can now be started. If any problems should occur, refer to <i>Section 7 Troubleshooting</i> . Perform homing after the power supply is turned ON.	Section 7

6-2 Preparing for Operation

This section explains the procedure that you perform to prepare the system for operation after installation and wiring of the Servomotor and Servo Drive are completed. It explains items to check both before and after turning ON the power supply.

6-2-1 Items to Check Before Turning ON the Power Supply

Checking Power Supply Voltage

Check to be sure that the power supply voltage is within the ranges shown below.

Model	Main circuit power supply	Control circuit power supply
R88D-1SN01H-ECT/-1SN02H-ECT/ -1SN04H-ECT/-1SN08H-ECT/-1SN15H-ECT (Single-phase/3-phase 200-VAC input)	Single-phase/ 3-phase 200 to 240 VAC (170 to 252 V) 50/60 Hz	24 VDC (21.6 to 26.4 V)
R88D-1SN10H-ECT (3-phase 200-VAC input)	3-phase 200 to 240 VAC (170 to 252 V) 50/60 Hz	24 VDC (21.6 to 26.4 V)

Checking Terminal Block Wiring

- The main circuit power supply inputs (L1/L2/L3) must be properly connected to the terminal block.
- The control circuit power supply inputs (24V, \emptyset or +24 V, 0V) must be properly connected to the terminal block.
- The motor's red (U), white (V), and blue (W) power lines and the green (\oplus) must be properly connected to the terminal block.

Checking the Servomotor

- There should be no load on the Servomotor. Do not connect mechanical systems.
- The Servomotor side power lines and the power cables must be securely connected.

Checking the Encoder Wiring

- The encoder cable must be securely connected to the encoder connector (CN2) at the Servo Drive.
- The encoder cable must be securely connected to the encoder connector of the Servomotor.

Checking the EtherCAT Communications Connectors

Do not connect the EtherCAT Communications Cables to the EtherCAT Communications Connectors (ECAT IN and ECAT OUT).

Checking the Node Address Setting

Make sure that the node address is correctly set on the ID switches.

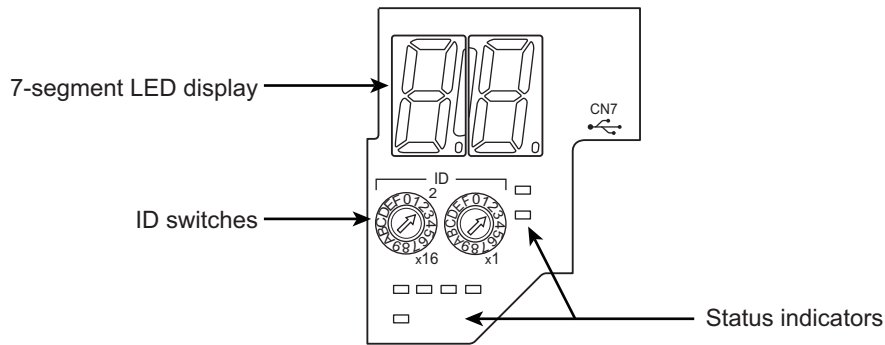

ID switch setting	Description
00	The controller sets the node address.
01 to FF	The ID switches set the node address.



Precautions for Correct Use

The ID switch setting is read only once when the Unit power supply is turned ON. Although the setting is changed after the Unit power supply is ON, it is not reflected in the control. It is enabled the next time the Unit power supply is turned ON.

6-2-2 Turning ON the Power Supply

Turn ON the control circuit power after you finish the checks which you must conduct before turning ON the power supply. You can turn ON the main circuit power, but it is not a required.

6-2-3 Checking the Displays

7-segment LED Display

The following figure shows the 7-segment LED display located on the front panel.

When the power is turned ON, it shows the node address that is set by the ID switches. Then the display changes according to the setting of the **LED Display Selection** (4210-01 hex).

An error code is displayed if an error occurs. A warning code is displayed if a warning occurs.

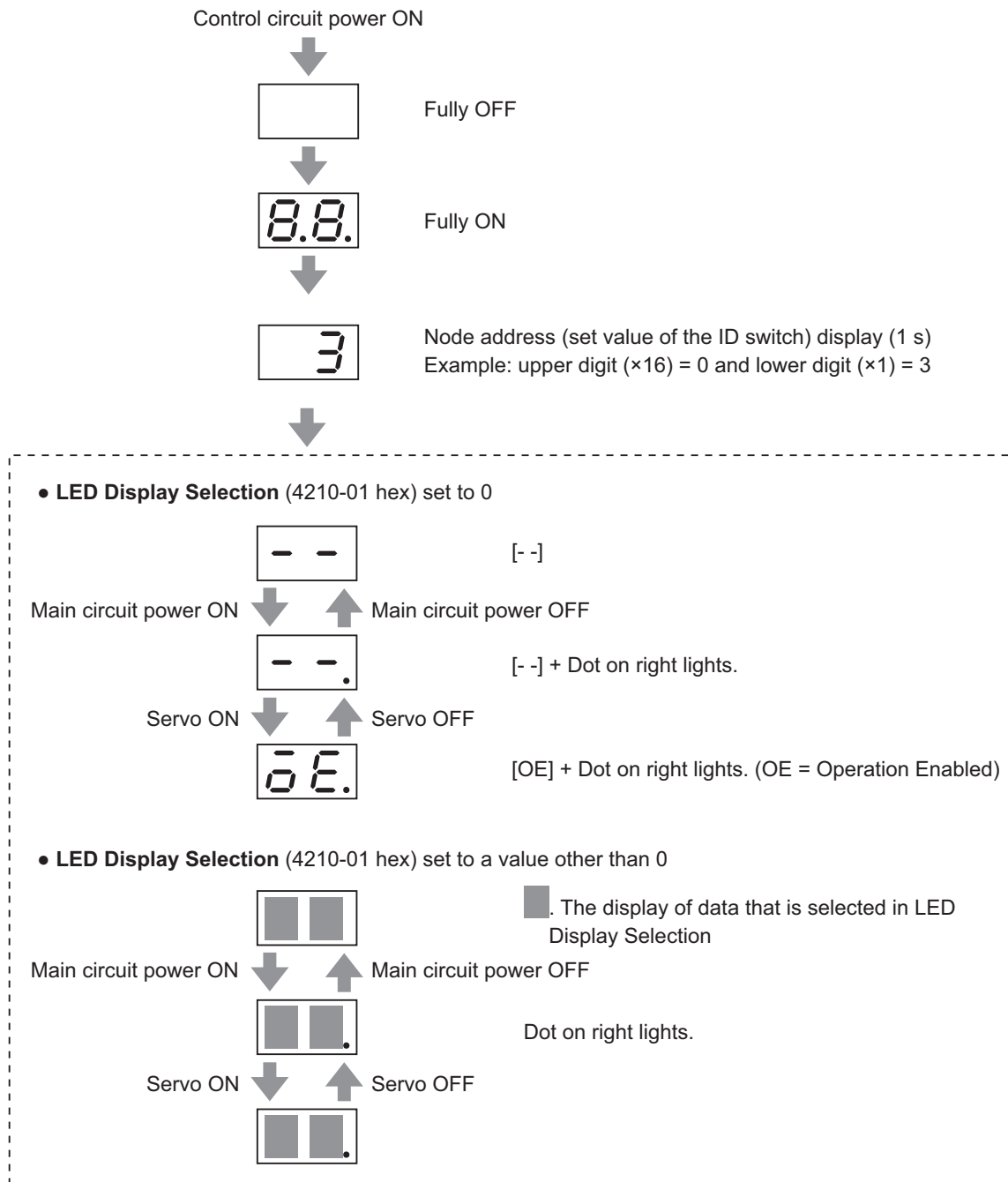

Error occurs ↓ ↑ Error reset
Warning occurs

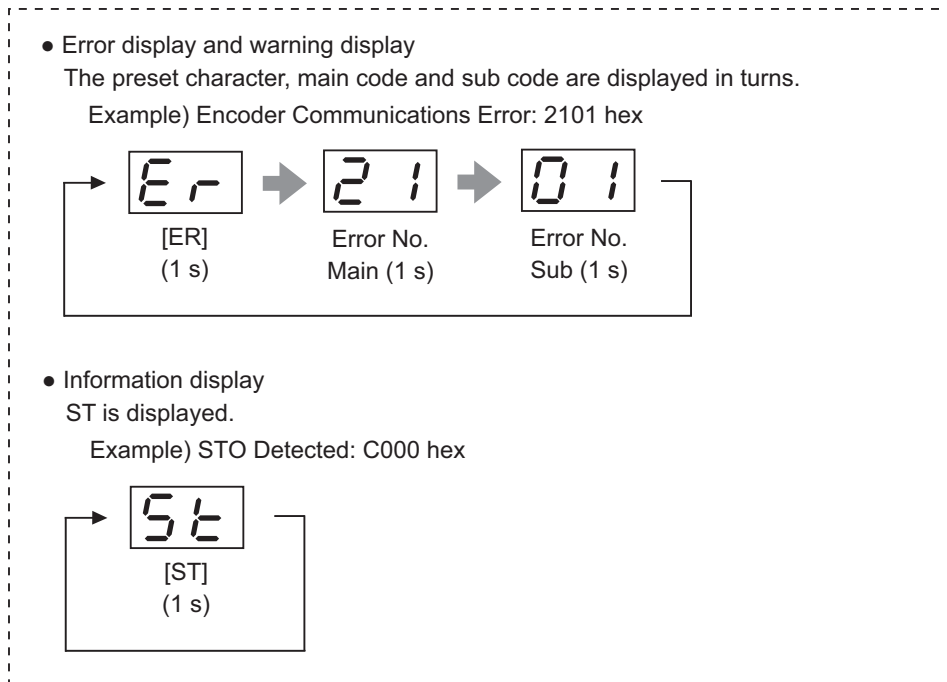

The node address is displayed as follows.

Node address	Expression	Display example
0 to 255	Expressed as 2-digit hexadecimal numbers from "0" to "FF".	 1 255 (FF hex)
256 to 511	The dot of the indicator is lit. The address is expressed as numbers from ".0" to "F.F".	 256 (100 hex) 511 (1FF hex)
512 or more	Expressed as "0.0".	 512 or more

Numbers from 0 to F hex are displayed as follows.

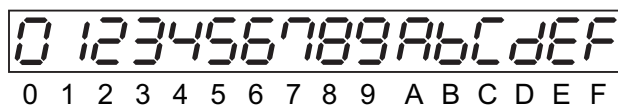

EtherCAT Status Indicators

Check the status of the status indicators.

If the RUN indicator does not turn ON or the ERR indicator does not turn OFF, refer to *AC Servomotors/Servo Drives 1S-series with Built-in EtherCAT® Communications User's Manual (I586)*.

6-3 Test Run

When you finished installation, wiring, and switch settings, and confirmed that the status was normal after turning ON the power supply, perform test run. The main purpose of test run is to confirm that the servo system operation is electrically correct.

If an error occurs during test run, refer to *Section 7 Troubleshooting* and eliminate the cause. Then check for safety, and retry test run.

6-3-1 Preparations for Test Run

Inspections Before Test Run

Check the following items.

● Wiring

- Make sure that there are no wiring errors (especially for the power supply input and motor output).
- Make sure that there are no short circuits. (Check the ground for short circuits as well.)
- Make sure that there are no loose connections.
- Make sure that the EtherCAT cable is pulled out.

● Power Supply and Voltage

- Make sure that the power voltage is within the specified range.
- Make sure that there is no voltage fluctuation.

● Servomotor Installation

- Make sure that the Servomotor is securely installed.

● Disconnection from Mechanical Systems

- If necessary, make sure that the load is disconnected from mechanical systems.



● Brake Released

- Make sure that the brake is released.

● Connection to Mechanical Systems

- Make sure that the load and Servomotor shaft are properly aligned.
- Make sure that the load on the Servomotor shaft is within specifications.

6-3-2 Test Run via USB Communications from the Sysmac Studio

- 1** Connect a sensor or other device to the control I/O connector (CN1).
- 2** Turn ON the Servo Drive power supply.
- 3** Connect a USB cable to the USB connector (CN7).
- 4** Start the Sysmac Studio and go online with the Servo Drive via USB communications.
- 5** In the Sysmac Studio, right-click the target Servo Drive under **Configurations and Setup**, and select **Test Run**.
- 6** Click the **Servo ON** button to apply the servo lock to the Servomotor.
- 7** Click the  or  button to start the Servomotor.

For how to use the Sysmac Studio, refer to the *Sysmac Studio Drive Functions Operation Manual* (Cat. No. I589).



Precautions for Correct Use

- A test run can be performed in the Profile position mode (pp) or Profile velocity mode (pv). If the torque compensation is set, the axes move because the compensation command is output when the Servo is turned ON.
 - When you perform a test run via USB communications, pull out the EtherCAT cable before you turn ON the power supply to the Servo Drive.
 - When you perform a test run from the Sysmac Studio without EtherCAT connection, you cannot use the STO function via EtherCAT communications. If you need the STO function, use the STO function via safety input signals. In this case, display the test run pane so that you can reset STO status via safety input signals.
 - If you need EtherCAT connection while you perform a test run from the Sysmac Studio without EtherCAT connection, first terminate the test run function and then perform EtherCAT connection.
-



Additional Information

When you use an NJ/NX-series CPU Unit, you can perform a test run from the Sysmac Studio via EtherCAT. In this case, you can use the STO function via EtherCAT communications.



Troubleshooting

This section explains the items to check when problems occur, and troubleshooting by the use of error displays or operation state.

7-1	Actions for Problems	7-2
7-1-1	Preliminary Checks When a Problem Occurs	7-2
7-1-2	Precautions When a Problem Occurs	7-3
7-1-3	Replacing the Servomotor or Servo Drive	7-4
7-2	Warnings	7-6
7-2-1	Related Objects	7-6
7-2-2	Warning List	7-8
7-3	Errors	7-10
7-3-1	Error List	7-10
7-3-2	Deceleration Stop Operation at Errors	7-12
7-4	Information	7-13
7-4-1	Related Objects	7-13
7-4-2	Information List	7-13
7-5	Troubleshooting	7-14
7-5-1	Troubleshooting Using Error Displays	7-14
7-5-2	Troubleshooting Using AL Status Codes	7-35
7-5-3	Troubleshooting Using the Operation State	7-39

7-1 Actions for Problems

If any problems should occur, take the following actions.

7-1-1 Preliminary Checks When a Problem Occurs

This section explains the preliminary checks required to determine the cause of a problem if one occurs.

Checking the Power Supply Voltage

Check the voltage at the power supply input terminals.

Input terminal	Model	Voltage
Main circuit power supply input (L1, L2, L3)	R88D-1SN□H-ECT	Single-phase/3-phase 200 to 240 VAC (170 to 252 V) ^{*1} 50/60 Hz
Control Circuit Power Supply Input Terminals (24 V, ∅ or +24 V, 0V)	---	24 VDC (21.6 to 26.4V)

*1. The values outside parentheses indicate the rated value, and the values inside parentheses indicate the range of acceptable variation. If the voltage is out of this range, operation failure may result. Be sure that the power supply is within the specified range.

Make sure that the power supply voltage for control input signals is within the range of 12 VDC-5% to 24 VDC+5%, and the power supply voltage for safety input signals is within the range of 24 VDC±5%. If the voltage is out of this range, operation failure may result. Be sure that the power supply is within the specified range.

Checking the Error Occurrence

Check whether an error exists by the use of the 7-segment LED display on the front of the Servo Drive or from the Sysmac Studio.

● When an Error Exists

Check the error display (□□) and make an analysis based on the error that is indicated.

Refer to *7-5-1 Troubleshooting Using Error Displays* on page 7-14.

● When an Error Does Not Exist

Make an analysis according to the error conditions.

Refer to *7-5-3 Troubleshooting Using the Operation State* on page 7-39.

The following figure shows the 7-segment display when an error exists.

- Error display and warning display

The preset character, main code and sub code are displayed in turns.

Example) Encoder Communications Error: 2101 hex

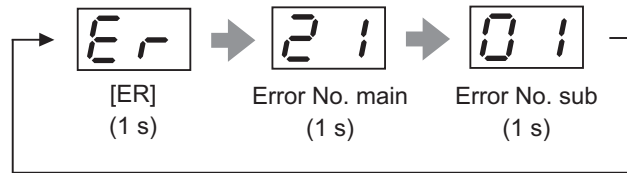

- Information display

ST is displayed.

Example) STO Detected: C000 hex

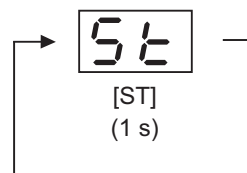

Numbers from 0 to F hex are displayed as follows.

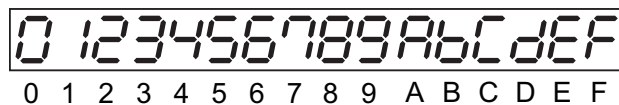

7-1-2 Precautions When a Problem Occurs

When you check and verify I/O after a problem occurred, the Servo Drive may suddenly start to operate or suddenly stop, so always take the following precautions.

You should assume that anything not described in this manual is not possible with this product.

Precautions

- Disconnect the wiring before checking for cable breakage. If you test conduction with the cable connected, test results may not be accurate due to conduction via bypassing circuit.
- If the encoder signal is lost, the Servomotor may run away, or an error may occur. Be sure to disconnect the Servomotor from mechanical systems before you check the encoder signal.
- When you perform tests, first check that there are no persons in the vicinity of the equipment, and that the equipment will not be damaged even if the Servomotor runs away. Before you perform the tests, verify that you can immediately stop the machine by the use of functions such as the immediate stop in case the machine runs out of control.

7-1-3 Replacing the Servomotor or Servo Drive

Use the following procedure to replace the Servomotor or Servo Drive.

Replacing the Servomotor

- 1** Replace the Servomotor.
- 2** In the position control, perform origin adjustment.
 - When you replace the motor, the motor's origin position (phase Z) may deviate, so you must perform origin adjustment.
 - Refer to the position controller's manual for details on performing origin adjustment.



Additional Information

With the Sysmac Studio, you can clear the Motor Operating Time retained by the Servo Drive.

Replacing the Servo Drive

- 1** Take a record of all object settings.
Use the Sysmac Studio to read all of the servo parameters in the Parameters tab page and save them in a file.
- 2** Replace the Servo Drive.
- 3** Set the objects.
Use the Sysmac Studio to write all of the servo parameters in the Parameters tab page.
- 4** Perform the Motor Setup.
 - When the Motor Replacement Detected (Error No. 95.05) occurs on the Servo Drive, use the Sysmac Studio to clear the Motor Replacement Detected.
 - When you use the Incremental Encoder Type Servomotors, you do not need to perform the Motor Setup.



Precautions for Correct Use

- Confirm that the charge lamp is not lit before you perform replacement of the Servo Drive.
- Usually, it takes at least 10 minutes to discharge electricity.
- The models with a regeneration resistor can discharge electricity in a short period of time when there is no error in its circuits and the main circuit power supply is cut off while the control power supply is ON.

Clearing Motor Replacement Detected

When you use the Incremental Encoder Type Servomotors, you do not need to perform the following procedure.

- 1** Start the Sysmac Studio and go online with the Servo Drive via EtherCAT or USB communications.
- 2** In the Sysmac Studio, right-click the target Servo Drive under **Configurations and Setup**, and select **Motor and Encoder**.
- 3** Click the **Reset Motor Replacement Detection error** button in the Encoder Properties pane.
- 4** Execute the Unit Restart or turn the control power supply to the Servo Drive OFF and then ON again.

7-2 Warnings

This function outputs a warning signal to enable you to check a state such as an overload before an error occurs.

With **Warning Customization** (4020 hex), you can select whether or not to detect warnings and whether or not to hold the warning state. Also, you can set this object to be notified of warnings as errors.

If **Warning Customization - Warning Hold Selection** (4020-04 hex) is set to a **not hold**, a warning is cleared automatically when the cause of warning is eliminated. If it is set to a **hold**, perform the normal procedure to clear errors after you remove the cause of the error.

7-2-1 Related Objects

Index (hex)	Subindex (hex)	Name	Description	Reference
4020	---	Warning Customization	Sets the warning detection function.	1586
	01	Warning Mask 1 Selection	When a bit is set to 1, the detection of the corresponding warning is disabled. bit 0: Overload Warning bit 1: Regeneration Overload Warning bit 2: Encoder Communications Warning bit 3: Motor Vibration Warning bit 4: Capacitor Lifetime Warning bit 5: Inrush Current Prevention Relay Lifetime Warning bit 7: Brake Interlock Output Relay Lifetime Warning bit 9: Lifetime Information Corruption Warning bit 10: Encoder Lifetime Warning bit 11: Fan Rotation Warning bit 12: Absolute Encoder Counter Overflow Warning	1586
	03	Warning Mask 3 Selection	When a bit is set to 1, the detection of the corresponding warning is disabled. bit 0: Data Setting Warning bit 1: Command Warning bit 2: EtherCAT Communications Warning	1586

Index (hex)	Subindex (hex)	Name	Description	Reference
4020	04	Warning Hold Selection	<p>Selects whether to hold or not the warning state.</p> <p>Bit 0:</p> <p>0: Not hold the warning enabled in Warning Mask 1 Selection.</p> <p>The warning is automatically cleared when the cause of the warning is eliminated. However, the warning is held for at least 1 second.</p> <p>1: Hold the warning enabled in Warning Mask 1 Selection.</p> <p>After the cause of the warning is eliminated, the error reset command must be sent.</p> <p>Bit 2:</p> <p>0: Not hold the warning enabled in Warning Mask 3 Selection.</p> <p>The warning is automatically cleared when the cause of the warning is eliminated. However, the warning is held for at least 1 second.</p> <p>1: Hold the warning enabled in Warning Mask 3 Selection.</p> <p>After the cause of the warning is eliminated, the error reset command must be sent.</p>	1586
	05	Warning Level Change 1 Selection	<p>When a bit is set to 1, the level of the corresponding warning is set as the error.</p> <p>bit 0: Overload Warning</p> <p>bit 1: Regeneration Overload Warning</p> <p>bit 2: Encoder Communications Warning</p> <p>bit 3: Motor Vibration Warning</p> <p>bit 4: Capacitor Lifetime Warning</p> <p>bit 5: Inrush Current Prevention Relay Lifetime Warning</p> <p>bit 7: Brake Interlock Output Relay Lifetime Warning</p> <p>bit 9: Lifetime Information Corruption Warning</p> <p>bit 10: Encoder Lifetime Warning</p> <p>bit 11: Fan Rotation Warning</p> <p>bit 12: Absolute Encoder Counter Overflow Warning</p>	1586
	07	Warning Level Change 3 Selection	<p>When a bit is set to 1, the level of the corresponding warning is set as the error.</p> <p>bit 0: Data Setting Warning</p> <p>bit 1: Command Warning</p> <p>bit 2: EtherCAT Communications Warning</p>	1586

7-2-2 Warning List

General Warnings

Error No.		Warning name	Warning condition	Warning Mask 1 Selection *1 (4020-01 hex) Warning Level Change 1 Selection (4020-05 hex) corresponding bit
Main (hex)	Sub (hex)			
A0	00	Overload Warning	The load ratio of Servo Drive or motor (4150-81 hex) exceeded the level set in Overload - Warning Notification Level (4150-01 hex).	Bit 0
A1	00	Regeneration Overload Warning	The Regeneration Load Ratio (4310-81 hex) exceeded 85% of the regeneration overload ratio.	Bit 1
A3	00	Fan Rotation Warning	The rotation speed of the fan is 80% or less of the rating and the cooling performance decreases.	Bit 11
A4	00	Encoder Communications Warning	Encoder communications errors occurred in series more frequently than the specified value.	Bit 2
A6	00	Motor Vibration Warning	The motor vibration, which was higher than or equal to the level set in the Vibration Detection - Detection Level (3B70-01 hex), was detected.	Bit 3
A7	01	Capacitor Lifetime Warning	The capacitor built into the Servo Drive reached the service life of the manufacturer's guarantee.	Bit 4
	02	Inrush Current Prevention Relay Lifetime Warning	The inrush current prevention relay built into the Servo Drive reached the service life of the manufacturer's guarantee.	Bit 5
	04	Brake Interlock Output Relay Lifetime Warning	The brake interlock output (BKIR) relay built into the Servo Drive reached the service life of the manufacturer's guarantee.	Bit 7
	05	Lifetime Information Corruption Warning	An error was detected in the saved lifetime information.	Bit 9
	06	Encoder Lifetime Warning	The encoder lifetime is close to the end.	Bit 10
AB	00	Absolute Encoder Counter Overflow Warning	The multi-rotation counter of the encoder exceeded the value set in Encoder - Absolute Encoder Counter Overflow Warning Level (4510-02 hex).	Bit 12

*1. For Warning Mask 1 Selection, when a bit is set to 1, the detection of the corresponding warning is disabled.



Precautions for Correct Use

You can clear these warnings by executing the error rest command. The command does clear the warning even if the cause of the warning is not removed, but the same warning will occur again.

EtherCAT Communications Warning

Error No.		Warning name	Warning condition	Warning Mask 3 Selection ^{*1} (4020-03 hex), Warning Level Change 3 Selection (4020-07 hex) corresponding bit
Main (hex)	Sub (hex)			
B0	00	Data Setting Warning	The object set value is out of the range.	Bit 0
B1	00	Command Warning	A command could not be executed.	Bit 1
B2	00	EtherCAT Communications Warning ^{*2}	An EtherCAT communications error occurred more than one time.	Bit 2

*1. For Warning Mask 3 Selection, when a bit is set to 1, the detection of the corresponding warning is disabled.

*2. This warning also occurs when the power supply to the master unit is turned OFF after EtherCAT communication establishment. For this reason, a warning may be recorded in the error history if the power supply to the 1S-series Servo Drive is turned OFF immediately after the power supply to the master unit is turned OFF.

7-3 Errors

If the Servo Drive detects an abnormality, it outputs an error (/ERR), turns OFF the power drive circuit, and displays the error number (main and sub) on the front panel.



Precautions for Correct Use

- Refer to 7-5-1 *Troubleshooting Using Error Displays* on page 7-14 for information on troubleshooting.
- You can reset the error by turning OFF the power supply and then ON again, or executing the error reset command via EtherCAT communications or on the Sysmac Studio. Be sure to remove the cause of the error first.
- Some errors are reset only by turning the power supply OFF then ON again. For details, refer to 7-3-1 *Error List* on page 7-10.
- If nothing is displayed on the 7-segment display even when the control power supply is ON, it indicates that the internal MPU is malfunctioning. If you find this symptom, cut off the power supply immediately.

7-3-1 Error List

Error No.		Error name	Attribute	
Main (hex)	Sub (hex)		Can be reset ^{*1}	Deceleration operation ^{*2}
12	00	Overvoltage Error	---	B
13	00	Main Power Supply Undervoltage (insufficient voltage between P and N)	Yes	B
	01	Main Circuit Power Supply Phase Loss Error	Yes	B
14	00	Overcurrent Error	---	B
	01	Power Module Error	---	B
	02	Regeneration Circuit Error Detected during Power ON ^{*3}	---	B
15	00	Servo Drive Overheat	Yes	B
	01	Motor Overheat Error	Yes	B
16	00	Overload Error	Yes	B
18	00	Regeneration Overload Error	---	B
	02	Regeneration Processing Error	---	B
20	00	Runaway Detected ^{*4}	---	B
21	00	Encoder Communications Disconnection Error	---	B
	01	Encoder Communications Error	---	B
24	00	Excessive Position Deviation Error	Yes	A
	01	Excessive Speed Deviation Error	Yes	A
26	00	Excessive Speed Error	Yes	A
27	01	Absolute Value Cleared	---	B
28	00	Pulse Output Overspeed Error	Yes	A
	01	Pulse Output Setting Error	---	A
29	03	Following Error Counter Overflow	---	B
33	00	General Input Allocation Duplicate Error	---	A
	09	General Output Allocation Duplicate Error	---	A
34	01	Software Limit Exceeded	Yes	A

Error No.		Error name	Attribute	
Main (hex)	Sub (hex)		Can be reset ^{*1}	Deceleration operation ^{*2}
35	00	FPGA WDT Error	---	B
	01	System Error	---	B
	02	Self-diagnosis Error	---	B
36	00	Non-volatile Memory Data Error	---	A
37	00	Non-volatile Memory Hardware Error	---	A
38	00	Drive Prohibition Input Error	Yes	A
	01	Drive Prohibition Detected	Yes	A
41	00	Absolute Encoder Counter Overflow Error	---	A
43	01	Encoder Memory Error	---	B
44	00	1-rotation Counter Error	---	B
45	00	Absolute Encoder Multi-rotation Counter Error ^{*5}	---	B
	01	Absolute Position Detection Error	---	B
47	00	Overspeed Error	---	B
58	00	Main Circuit Temperature Monitoring Circuit Failure	---	B
59	00	Fan Error	Yes	A
62	00	Control Right Release Error	Yes	A
70	00	Safety Parameter Error	Yes	A
	01	Safety Communications Setting Error	Yes	A
	02	FSoE Slave Address Error	Yes	A
	03	Safety Frame Error	Yes	A
	04	Safety Communications Timeout	Yes	A
83	01	EtherCAT State Change Error	Yes	A
	02	EtherCAT Illegal State Change Error	Yes	A
	03	Communications Synchronization Error	Yes	A
	04	Synchronization Error	Yes ^{*6}	A
	05	Sync Manager WDT Error	Yes	A
	06	Bootstrap State Transition Request Error	Yes	A
87	00	Error Stop Input	Yes	A
88	01	ESC Initialization Error	---	A
	02	Synchronization Interruption Error	---	A
	03	SII Verification Error	---	A
	04	ESC Error	---	A
90	00	Mailbox Setting Error	Yes	A
	01	PDO WDT Setting Error	Yes	A
	02	SM Event Mode Setting Error	Yes	A
	03	DC Setting Error	Yes	A
	04	Synchronization Cycle Setting Error	Yes	A
	05	RxPDO Setting Error	Yes	A
	06	TxPDO Setting Error	Yes	A
	07	RxPDO Mapping Error	Yes	A
	08	TxPDO Mapping Error	Yes	A
09	Node Address Updated	---	A	
91	01	Command Error	Yes	A
93	00	Electronic Gear Setting Error	---	A
94	00	Function Setting Error	Yes	A
95	01	Motor Non-conformity	---	A
	05	Motor Replacement Detected ^{*4}	---	A
97	00	Brake Interlock Error	---	B

*1. "Yes" means that you can clear the error by executing the error reset command. The mark "---" means that you need to cycle the power supply or execute **Unit Restart** (2400 hex) to clear the error.

- *2. The deceleration operation shows the operation (*Operation A* or *Operation B*) that is used when **Fault reaction option code** (605E hex) is set to -4 to -7.
- *3. This error can occur in the unit version 1.2 or later.
- *4. This error can occur in the unit version 1.1 or later.
- *5. This error cannot occur in the Incremental Encoder Type Servomotors.
- *6. “---” is specified for the unit version 1.0.

7-3-2 Deceleration Stop Operation at Errors

The deceleration stop function controls the motor and decelerates it to stop if an error that causes the deceleration stop occurs.

Related Objects

Index (hex)	Subindex (hex)	Name	Description	Reference
605E	00	Fault reaction option code	Sets the state during deceleration and after stopping for when an error occurs.	I586
3B21	---	Deceleration Stop	Sets the torque for deceleration stop.	I586
	01	Torque	Sets the torque limit value during deceleration stop.	I586

Deceleration Stop Operation

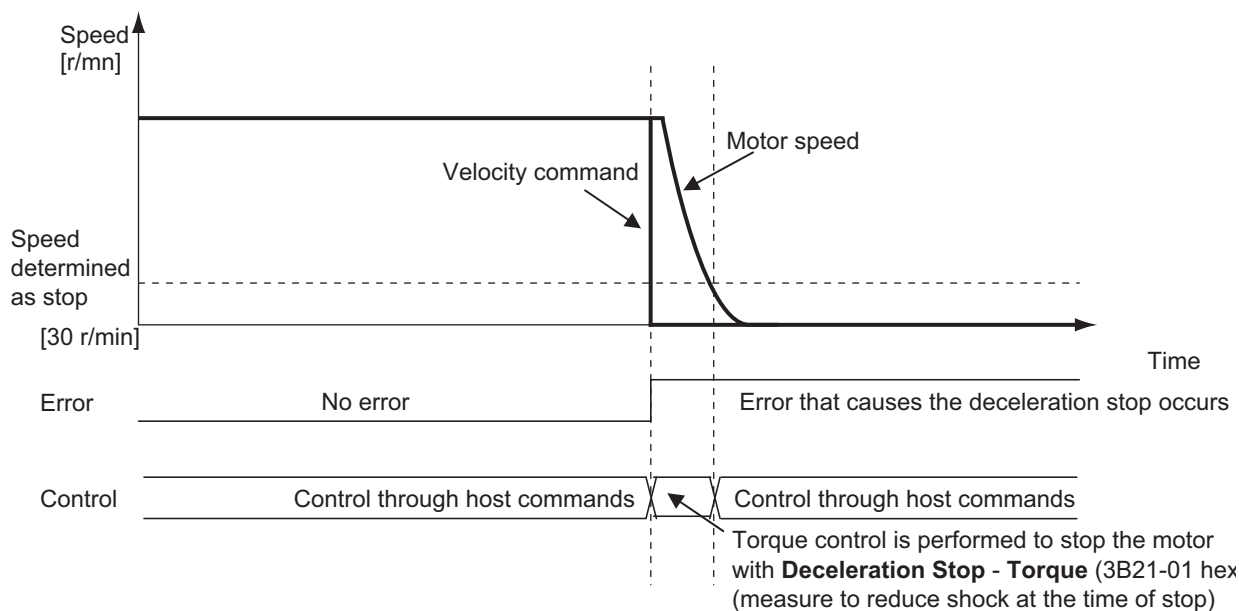

7-4 Information

Information is an event other than errors of which you are notified.

You can change information to errors by changing its level.

7-4-1 Related Objects

Index (hex)	Subindex (hex)	Name	Description	Reference
4030	---	Information Customization	Sets the information.	I586
	01	Information Level Change Selection	Sets the level change of information. When a bit is set to 1, the level of the corresponding information is set as the error. Bit 0: STO	I586

7-4-2 Information List

Error No.		Information name	Warning condition	Information Level Change Selection ^{*1} (4030-01 hex)
Main (hex)	Sub (hex)			
C0	00	STO Detected	STO status	Bit 0

*1. For **Information Level Change Selection**, when a bit is set to 1, the level of the corresponding information is set as the error.

7-5 Troubleshooting

If an error occurs in the Servo Drive or operation, identify the cause of the error and take appropriate measures as shown below.

- For the error occurrence, check its frequency, timing, and the environment in which the error occurred.
- You can reduce errors that occur temporarily by taking noise countermeasures such as wiring a thick ground wire as short as possible.
- For details on noise countermeasures, refer to *4-3 Wiring Conforming to EMC Directives* on page 4-8.

7-5-1 Troubleshooting Using Error Displays

When an error or warning occurs, the error number is displayed on the 7-segment LED display the front of the Servo Drive.

Error List

Error No.		Name	Cause	Measures	
Main (hex)	Sub (hex)				
12	00	Overvoltage Error	The main circuit power supply voltage (P-N voltage) exceeded the operation guarantee range.	The P-N voltage exceeded the specified value.	Input the correct voltage.
				The input voltage increased.	Use appropriately external devices such as UPS.
				The Regeneration Resistor wiring is broken.	If a resistance value of the external resistor is infinite between the terminal B1 and B2 of the Servo Drive, the wiring is broken. Replace the external resistor.
				The External Regeneration Resistor is set or selected inappropriately.	Confirm the necessary regeneration processing capacity, and connect an appropriate External Regeneration Resistor. Also, set the parameters of the External Regeneration Resistor to the resistance value of the External Regeneration Resistor in use.
			Servo Drive failure	If this event occurs again after you performed all corrections shown above, replace the Servo Drive.	

Error No.		Name	Cause	Measures	
Main (hex)	Sub (hex)				
13	00	Main Power Supply Undervoltage (insufficient voltage between P and N)	The main circuit power supply voltage fell below the operation guarantee range during Servo ON.	Incorrect wiring of the main circuit power supply	If the power supply cables are not wired to the main circuit power supply terminals (L1 , L2 , L3), connect them.
				The low power supply voltage is applied to the Servo Drive.	Increase the power supply capacity if it is small. Measure the applied power supply voltage, and apply the voltage according to the specification.
				The long time was set in Momentary Hold Time and the voltage was decreased momentarily.	Remove the cause that momentarily decreased the voltage. Set a short time in the Momentary Hold Time so as not to detect this error due to a momentary decrease in voltage.
				Servo Drive failure	If this event occurs again after you performed all corrections shown above, replace the Servo Drive.
	01	Main Circuit Power Supply Phase Loss Error	The phase loss of the main circuit power supply was detected.	Incorrect wiring, for example the single-phase power supply is input to a 3-phase input type Servo Drive.	Confirm the Servo Drive specifications, and perform the correct wiring.
				In the case where the single-phase power supply is input to a single- and 3-phase input type Servo Drive, the phase loss detection is enabled.	Set Main Circuit Power Supply - Phase Loss Detection Enable (4320-02 hex) to 0 (disabled).
				The power supply voltage is low or insufficient.	Improve power supply conditions by increasing the power supply capacity or the like.
				Broken wiring of the main circuit power supply input	Replace the main circuit power supply input cable.
				Servo Drive failure	If this event occurs again after you performed all corrections shown above, replace the Servo Drive.

Error No.		Name	Cause		Measures
Main (hex)	Sub (hex)				
14	00	Overcurrent Error	The current flowing to the motor exceeded the protection level.	There is a short circuit, ground fault, or contact failure on the U, V, or W motor cable.	Correct the connection of the U, V, or W motor cable.
				There is a short circuit on the wiring of External Regeneration Resistor.	Correct the wiring of External Regeneration Resistor.
				The insulation resistance failed between the U, V, or W motor cable and the motor ground wire.	Replace the motor.
				False detection due to the noise	Take noise countermeasures.
				Servo Drive failure	If this event occurs again after you performed all corrections shown above, replace the Servo Drive.
	01	Power Module Error	An error was detected in the power module.	There is a short circuit, ground fault, or contact failure on the U, V, or W motor cable.	Correct the connection of the U, V, or W motor cable.
				There is a short circuit on the wiring of External Regeneration Resistor, or the value of resistance became too small.	If there is a short-circuit on the wiring of External Regeneration Resistor, correct the wiring.
				The insulation resistance failed between the U, V, or W motor cable and the motor ground wire.	Replace the motor.
				Servo Drive failure	If this event occurs again after you performed all corrections shown above, replace the Servo Drive.

Error No.		Name	Cause	Measures
Main (hex)	Sub (hex)			
14	02	Regeneration Circuit Error Detected during Power ON* ¹	<p>An error of the Regeneration Circuit was detected at power ON.</p> <ul style="list-style-type: none"> • Power supply voltage is insufficient at power ON, or rising slowly. • Power supply voltage fluctuated at power ON. • L1, L2, and L3 terminals are not connected or disconnected. • N1 and N2 terminals are opened. 	<p>Cut off the main circuit power supply immediately and check whether charge lamp is turned ON/OFF.</p> <p>If the charge lamp is turned OFF, remove the wiring and make the following check.</p> <ul style="list-style-type: none"> • Check whether there is an abnormality in the appearance of the Servo Drive, and that the wiring is properly done. • Check that the resistance value and the power of the External Regeneration Resistor is correct. • Wait until the voltage between P and N1 goes to less than 1 V to check the resistance value between P and N1. (If it is less than 10 kΩ, replace the Servo Drive.) • Wait until the voltage get stable to check the resistance value between B2 and N1. (If it is less than 100 kΩ, replace the Servo Drive.) • Check whether fluctuation in the power supply voltage or power supply occurs or not. (Make sure that an instantaneous power drop does not occur, and that the power rise time is 500 ms or shorter.) <p>If the charge lamp is turned ON, check whether fluctuation in the power supply voltage or power supply occurs or not. (Make sure that an instantaneous power drop does not occur, and that the power rise time is 500 ms or shorter.)</p>
			Servo Drive failure	If this event occurs again after you performed all corrections shown above, replace the Servo Drive.

Error No.		Name	Cause	Measures	
Main (hex)	Sub (hex)				
15	00	Servo Drive Overheat	The internal temperature of Servo Drive exceeded the circuit protection level.	The ambient temperature of the Servo Drive exceeded the specified value.	Improve the ambient temperature and the cooling conditions of the Servo Drive.
			Overload	Increase the setting of the acceleration/deceleration time or stopping time to lighten the load. Or, increase the capacities of the Servo Drive and the motor.	
	01	Motor Overheat Error	The encoder detected the temperature that exceeded the protection level of motor.	The temperature is high around the motor.	Adjust the temperature around the motor to be within the range of the operating temperature.
				The motor is overloaded.	Adjust the motor load ratio to be within the specified range.
16	00	Overload Error	The load ratio of Servo Drive or motor (4105-81 hex) exceeded 100%.	Operation was continued for a long time with high load.	Take the following actions according to conditions. <ul style="list-style-type: none"> • Increase the set value of the acceleration/deceleration time or the stop time. • Lighten the load. • Adjust the gain or inertia ratio. • If torque waveforms oscillate excessively, adjust the system by the tuning so that the oscillation does not occur. • Set the appropriate brake timing. • Increase the capacities of the Servo Drive and the motor.
				There is incorrect wiring of the motor cable or a broken cable.	<ul style="list-style-type: none"> • Connect the motor cable as shown in the wiring diagram. If the cable is broken, replace it. Or, connect the motor cable and encoder cable that are used together to the same motor. • Measure the voltage at the brake terminal. If the brake is applied, release it.
				Increase in friction	Check machine conditions and remove the cause of the friction.

Error No.		Name	Cause	Measures	
Main (hex)	Sub (hex)				
18	00	Regeneration Overload Error	The Regeneration Load Ratio (4310-81 hex) exceeded the regeneration overload ratio.	The regeneration processing is set inappropriately.	Check the regeneration processing setting, and set the same value as the resistance value of the Regeneration Resistor in use.
				The Regeneration Resistor is selected inappropriately.	Check the operation pattern by the velocity monitor. Check the load ratio of Regeneration Resistor, and perform the following corrections accordingly. <ul style="list-style-type: none"> • Increase the deceleration time and stopping time. • Decrease the command velocity to the motor. • Use an External Regeneration Resistor. • Increase the capacities of the Servo Drive and the motor.
				The Regeneration Resistor is used for continuous regenerative braking.	The Regeneration Resistor cannot be used for continuous regenerative braking.
				The applied power supply voltage is higher than the specified value.	Apply the specified power supply voltage.
				Regeneration Resistor failure	Check whether the Regeneration Resistor is faulty, and use one without failures.
	02	Regeneration Processing Error	<p>The regeneration processing was stopped to protect the Regeneration Resistor.</p> <p>This error occurs when the regeneration processing continues for 500 ms or more.</p>	The regeneration processing is set inappropriately.	Check the regeneration processing setting, and set the same value as the resistance value of the Regeneration Resistor in use.
				The Regeneration Resistor is selected inappropriately.	Check the operation pattern by the velocity monitor. Check the load ratio of Regeneration Resistor, and perform the following corrections accordingly. <ul style="list-style-type: none"> • Increase the deceleration time and stopping time. • Decrease the command velocity to the motor. • Use an External Regeneration Resistor. • Increase the capacities of the Servo Drive and the motor.
				The Regeneration Resistor is used for continuous regenerative braking.	The Regeneration Resistor cannot be used for continuous regenerative braking.
				The applied power supply voltage is higher than the specified value.	Apply the specified power supply voltage.
				Regeneration Resistor failure	Check whether the Regeneration Resistor is faulty, and use one without failures.

Error No.		Name	Cause	Measures	
Main (hex)	Sub (hex)				
20	00	Runaway Detected*2	The motor rotated in the direction opposite to the command.	There is incorrect wiring of the motor cable or a broken cable. The motor rotated in the direction opposite to the command by external forces.	Connect the motor cable as shown in the wiring diagram. If the cable is broken, replace it. Or, connect the motor cable and encoder cable that are used together to the same motor. Take countermeasures so that the motor is not subjected to external forces. Set Runaway Detection - Enable (3B71-01 hex) to 0 (disabled) when the motor runs as intended.
21	00	Encoder Communications Disconnection Error	The communications disconnection was detected between the encoder and the Servo Drive. This error is detected if the encoder communications timeout occurs four times in a row.	Noise into the encoder cable	<ul style="list-style-type: none"> Separate the motor cable and the encoder cable if they are bundled together. Connect the shield to FG. Confirm that the motor ground wire is connected to FG.
				Contact failure of the signal line, and disconnection of the encoder	Replace the encoder cable if it is broken. Firmly connect the encoder connector to the Servo Drive.
				Power supply undervoltage to the encoder	Use the recommended encoder cable.
				Encoder failure	If this event occurs after you performed all corrections shown above, replace the motor.
	01	Encoder Communications Error	Illegal data was received from the encoder the specified number of times. This error is detected if the data error occurs four times in a row during communications with the encoder.	Noise into the encoder cable	<ul style="list-style-type: none"> Separate the motor cable and the encoder cable if they are bundled together. Connect the shield to FG. Check that the motor ground wire is connected to FG.
					Contact failure of the signal line, and disconnection of the encoder
				Power supply undervoltage to the encoder	Use the recommended encoder cable.

Error No.		Name	Cause		Measures
Main (hex)	Sub (hex)				
24	00	Excessive Position Deviation Error	The position deviation is greater than or equal to the value set in the Following error window.	The motor operation does not follow the command.	Identify and remove a cause that limits the motor operation. During the acceleration/deceleration, the command may not be followed depending on operation patterns. In that case, adjust the gain, increase the acceleration/deceleration time or the like.
				The value of Following error window is small.	Increase the setting of the Following error window to an acceptable range.
	01	Excessive Speed Deviation Error	The speed deviation is greater than or equal to the value set in the Excessive Velocity Deviation Detection Level.	The motor operation does not follow the command because a parameter value is inappropriate.	Adjust the gain to improve the following ability. Or, increase the acceleration/deceleration time for the internal position command velocity.
				The output axis of motor is limited on the operation by external forces.	Take countermeasures so that the output axis is not limited on the operation by external forces.
				The value of the Excessive Velocity Deviation Detection Level is inappropriate.	Increase the setting of the Excessive Velocity Deviation Detection Level to an acceptable range. Disable the Excessive Velocity Deviation Detection if it is unnecessary to monitor the velocity deviation.
	26	00	Excessive Speed Error	The feedback motor speed is greater than or equal to the value set in the Excessive Speed Detection Level.	The velocity command value is too large.
Overshooting occurred.					If overshooting occurred due to faulty gain adjustment, adjust the gain.
The motor is rotated by external forces.					Check whether the motor is rotated by external forces.
27	01	Absolute Value Cleared	The multi-rotation counter of the absolute encoder was cleared.		This operation is performed for safety and is not an error.
28	00	Pulse Output Overspeed Error	The speed, which exceeded the frequency that could be output by the Encoder Dividing Pulse Output function, was detected.	The dividing ratio setting is inappropriate for the actual usage condition.	Correct the setting of Encoder Dividing Pulse Output - Dividing Denominator and Dividing Numerator.
	01	Pulse Output Setting Error	The dividing numerator exceeded the dividing denominator when the Encoder Dividing Pulse Output - Dividing Denominator was set to a value other than 0.		Correct the setting of Encoder Dividing Pulse Output - Dividing Denominator and Dividing Numerator.

Error No.		Name	Cause		Measures
Main (hex)	Sub (hex)				
29	03	Following Error Counter Overflow	The following error value exceeded the range from -2,147,483,648 to 2,147,483,647.	The motor operation does not follow the command.	Identify and remove a cause that limits the motor operation. During the acceleration/deceleration, the command may not be followed depending on operation patterns. In that case, change the operation pattern by increasing the acceleration/deceleration time or the like.
				The motor is rotated or limited on the operation by external forces.	
33	00	General Input Allocation Duplicate Error	More than one function input is allocated to one general input.		Correct the duplicate general input allocation.
	09	General Output Allocation Duplicate Error	More than one function output is allocated to one general output.		Correct the duplicate general output allocation.
34	01	Software Limit Exceeded	The Position actual value detected the position that exceeded the value set in the Software Position Limit, and stopped the operation according to the user setting.	Incorrect setting of Software Position Limit	Correct the setting of Software Position Limit. Set the command value to be within the range of Software Position Limit.
				When the Software Position Limit - Stop Selection was set to a <i>Stop according to the setting of Fault reaction option code</i> , the position exceeded the value set in the Software Position Limit.	
35	00	FPGA WDT Error	An FPGA error was detected.	False detection due to a data read error that was caused by excessive noise	If this event does not occur after you cycled the power supply, use the product continuously. It is supposed that a temporary error occurred due to a read error. If this event occurs again, the hardware is faulty. Replace the Servo Drive.
				Hardware failure	
	01	System Error	A hardware error due to the self-diagnosis and a fatal software error were detected.	False detection due to a data read error that was caused by excessive noise	If this event does not occur after you cycled the power supply, use the product continuously. It is supposed that a temporary error occurred due to a read error. If this event occurs again, a fatal error exists. Replace the Servo Drive.
				A fatal software error was detected.	
				Hardware failure	
	02	Self-diagnosis Error	An error was detected by the self-diagnosis of the safety function.	False detection due to a data read error that was caused by excessive noise	If this event does not occur after you cycled the power supply, use the product continuously. It is supposed that a temporary error occurred due to a read error. If this event occurs again, replace the Servo Drive.
Hardware failure					

Error No.		Name	Cause	Measures	
Main (hex)	Sub (hex)				
36	00	Non-volatile Memory Data Error	An error of data saved in the non-volatile memory was detected.	Power interruption or noise occurred while parameters other than the safety were saved	Save data after setting the parameter again, and cycle the power supply.
				Power interruption or noise occurred while the motor identity information was saved	Execute Motor Setup, and cycle the power supply.
				Power interruption or noise occurred while safety parameters were saved	Clear the FSoE slave address, execute FSoE Enable Reset, and cycle the power supply.
37	00	Non-volatile Memory Hardware Error	An error occurred on the non-volatile memory.	False detection due to a data read error that was caused by excessive noise	After you cycled the power supply, if this error occurs continuously although the error is reset, the non-volatile memory is faulty. Replace the Servo Drive.
				Non-volatile memory failure	
38	00	Drive Prohibition Input Error	Both the Positive Drive Prohibition (POT) and the Negative Drive Prohibition Input (NOT) turned ON.	An error occurred on the switch, wire, power supply, and wiring that was connected to the Positive Drive Prohibition Input (POT) or Negative Drive Prohibition Input (NOT).	Check and correct an error on the switch, wire, power supply, and wiring that is connected to the Positive Drive Prohibition Input or Negative Drive Prohibition Input.
					False detection occurred because the control signal power supply was turned ON slowly.
	01	Drive Prohibition Detected	The operation was stopped according to the user setting because the motor ran in the prohibited direction when the Drive Prohibition was enabled.	Incorrect or broken wiring of Positive Drive Prohibition Input (POT) or Negative Drive Prohibition Input (NOT)	Correct the wiring if the Positive Drive Prohibition Input (POT) or Negative Drive Prohibition Input (NOT) is wired incorrectly. If the cable is broken, replace it.
				Incorrect setting of the Drive Prohibition Input	Review the setting of the drive prohibition input port and set it correctly.
41	00	Absolute Encoder Counter Overflow Error	The multi-rotation counter of the encoder exceeded the maximum number of rotations.	An inappropriate value was set in the Encoder - Operation Selection when Using Absolute Encoder (4510-01 hex).	Set the appropriate value in the Encoder - Operation Selection when Using Absolute Encoder (4510-01 hex).
					The multi-rotation number of the encoder exceeded the maximum number of rotations.

Error No.		Name	Cause	Measures	
Main (hex)	Sub (hex)				
43	01	Encoder Memory Error	The encoder detected a non-volatile memory error.	False detection due to a data read error that was caused by excessive noise	If this event occurs after you cycled the power supply, the encoder is faulty. Replace the motor.
				Non-volatile memory failure	
44	00	1-rotation Counter Error	The encoder detected a one-rotation counter error.	There is excessive noise.	Take noise countermeasures. If this event occurs after you performed noise countermeasures, the motor is faulty. Replace the motor.
				Failure due to vibration, impact, condensation or foreign matter, etc.	
45	00	Absolute Encoder Multi-rotation Counter Error	The encoder detected a multi-rotation counter error.	A temporary error occurred in the encoder multi-rotation detection function due to vibration, impact, or condensation.	Use the product continuously if this event does not occur after improving the operating environment. Replace the motor if this event occurs again.
				Encoder failure	
	01	Absolute Position Detection Error	The encoder detected a multi-rotation counter error.	A detection error was detected in the multi-rotation detection section of the encoder.	Perform the Absolute Encoder Setup after cycling the power supply, and update the multi-rotation number.
				There is excessive noise.	Take noise countermeasures. Replace the motor if this event occurs repeatedly.
47	00	Overspeed Error	The encoder detected the overspeed.	The motor is rotated by external forces.	Take countermeasures so that the motor is not subjected to external forces if the motor is rotated by external forces.
				Encoder failure and false detection	If this event occurs repeatedly, the encoder is faulty. Replace the motor.
58	00	Main Circuit Temperature Monitoring Circuit Failure	A temperature monitoring circuit failure was detected on the main circuit.		If this event occurs repeatedly after you cycled the power supply, Replace the Servo Drive.
59	00	Fan Error	The rotation speed of the fan is 40% or less of the rating and the cooling performance decreases.	There is a foreign matter in the cooling fan and it blocks the rotation.	Check whether there is a foreign matter in the fan. If you find a foreign matter, remove it.
				Cooling fan failure	If there is no improvement after you performed the correction above, replace the Servo Drive.

Error No.		Name	Cause		Measures
Main (hex)	Sub (hex)				
62	00	Control Right Release Error	Communications between the Sysmac Studio and Servo Drive were interrupted while a specific function was used from the Sysmac Studio. This error is detected when the FFT, test run, or control output check function is used.	The USB cable or EtherCAT cable was disconnected during the connection with the Sysmac Studio.	Connect the USB cable or EtherCAT cable between the Servo Drive and the computer that controls the Servo Drive if it is disconnected.
				There is excessive noise.	Take noise countermeasures for the USB cable or EtherCAT cable.
				A command sent from the Sysmac Studio was not sent to the Servo Drive because the computer was in a busy state or the like.	Finish other applications to reduce the processing load of the computer.
70	00	Safety Parameter Error	Safety process data communications were not established with the Safety CPU Unit because an incorrect parameter was received.		Check whether the connected safety slave model matches the safety slave model that is set from the Sysmac Studio, and correct it.
	01	Safety Communications Setting Error	Safety process data communications were not established with the Safety CPU Unit because of an incorrect communications setting.	The watchdog time was set incorrectly.	If the watchdog time of the safety process data communications setting was set to a value inappropriate for the communications cycle or the configuration, correct it, and transfer the setting to the Safety CPU Unit.
				The processing was not completed within the watchdog time because communications were not established due to the noise.	If there is no improvement after you performed noise countermeasures, set the longer watchdog time, and transfer the setting to the Safety CPU Unit.
	02	FSoE Slave Address Error	Safety process data communications were not established with the Safety CPU Unit because of an incorrect FSoE slave address.		Perform the FSoE Slave Address Clear for the Servo Drive.
	03	Safety Frame Error	Safety process data communications were not established with the Safety CPU Unit because an incorrect frame was received.	An incorrect frame was received in safety process data communications.	The Servo Drive model does not match the safety slave model that is sent from the safety master. Check the connection configuration and configure it correctly.
				There is excessive noise.	Take noise countermeasures.
	04	Safety Communications Timeout	A communications timeout occurred in safety process data communications with the Safety CPU Unit.	A setting is not correct. The setting of the safety task period of the Safety CPU Unit is too short.	Increase the safety task period of the Safety CPU Unit and then transfer the settings to the Safety CPU Unit.
				There is excessive noise.	Take noise countermeasures.
				The Safety CPU Unit or safety slave entered a status where it could not continue safety process data communications.	Check the status of the Safety CPU Unit or safety slave.

Error No.		Name	Cause		Measures
Main (hex)	Sub (hex)				
83	01	EtherCAT State Change Error	A communications state change command was received for which the current communications state could not be changed.		Check the command specifications for communications state transitions in the host controller and correct host controller processing.
	02	EtherCAT Illegal State Change Error	An undefined communications state change command was received.		Check the command specifications for communications state transitions in the host controller and correct host controller processing.
	03	Communications Synchronization Error	Communications were not established consecutively because the synchronization with the EtherCAT Master could not be achieved.	The power supply to the host controller was interrupted during PDO communications.	Reset the error in the host controller. This event reports an error that was detected when the power supply to the host controller was interrupted. It does not indicate that an error currently exists.
				An EtherCAT communications cable is disconnected, loose, broken, or has a contact failure.	Connect the EtherCAT communications cable securely. If the cable is broken, replace it.
				Noise	Take noise countermeasures if excessive noise affects the EtherCAT communications cable.
	04	Synchronization Error	A signal for synchronous communications could not be detected.	Noise	Take noise countermeasures if excessive noise affects the EtherCAT communications cable.
				Error of the EtherCAT slave communications controller	If this event occurs again after you cycled the power supply, replace the Servo Drive.
05	Sync Manager WDT Error	PDO communications were interrupted for the allowable period or longer.	An EtherCAT communications cable is disconnected, loose, or broken.	Connect the EtherCAT communications cable securely.	
			Host controller error	Check the operation of the host controller. Take appropriate countermeasures if there is a problem.	
06	Bootstrap State Transition Request Error	The state transition to unsupported Bootstrap was requested.	Check the EtherCAT master setting so that the EtherCAT master does not request the transition to Bootstrap.		
87	00	Error Stop Input	The Error Stop Input (ESTP) is active.	The Error Stop Input (ESTP) was input.	Remove the cause of Error Stop Input (ESTP).
				The Error Stop Input (ESTP) is incorrectly wired.	Correct the wiring if the Error Stop Input (ESTP) is incorrectly wired.

Error No.		Name	Cause	Measures	
Main (hex)	Sub (hex)				
88	01	ESC Initialization Error	The initialization of EtherCAT slave communications controller failed.	Data was incorrectly written in the non-volatile memory of the EtherCAT slave communications controller. Failure of the EtherCAT slave communications controller	If this event does not occur after you cycled the power supply, use the product continuously. It is supposed that a temporary error occurred due to a read error. If this event occurs again, replace the Servo Drive.
			Synchronization Interruption Error	Synchronization interruption did not occur within the specified period. Incorrect EtherCAT synchronization setting of the host controller. Failure of the EtherCAT slave communications controller or false detection	Set the synchronization setting of the host controller according to the synchronization specifications for the EtherCAT slave. If this event does not occur after you cycled the power supply, use the product continuously. It is supposed that a temporary error occurred due to a read error. If this event occurs again, the Servo Drive is faulty. Replace the Servo Drive.
	03	SII Verification Error	An error occurred in SII data of the EtherCAT slave communications controller.	Data was incorrectly overwritten in the non-volatile memory of the EtherCAT slave communications controller. Failure of the EtherCAT slave communications controller or false detection	If this event does not occur after you cycled the power supply, use the product continuously. It is supposed that a temporary error occurred due to a read error. If this event occurs again, replace the Servo Drive.
				04	ESC Error

Error No.		Name	Cause		Measures
Main (hex)	Sub (hex)				
90	00	Mailbox Setting Error	An incorrect mailbox setting of Sync Manager was detected.		Check the mailbox setting, and then download it to the EtherCAT master again.
	01	PDO WDT Setting Error	An incorrect PDO WDT setting was detected.		Check the PDO WDT setting, and then download it to the EtherCAT master again.
	02	SM Event Mode Setting Error	The unsupported SM Event Mode was set.		Check the synchronization setting, and then download it to the EtherCAT master again.
	03	DC Setting Error	A mistake was made in the DC Mode operation setting.		Check the DC Mode setting, and then download it to the EtherCAT master again.
	04	Synchronization Cycle Setting Error	When the DC mode was established, the cycle time was set to the inoperable value. In the variable PDO mapping, the maximum number of objects you can map is specified as follows: 6 for both RxPDO and TxPDO for the communication period of 125 μ s, 10 for both RxPDO and TxPDO for other communication periods. An error occurs if you map a larger number of objects than that specified above. This error is also detected in the following case: the cycle time is an integral multiple of 125 μ s and is not 10 ms or lower.	The variable PDO mapping is used, and the number of objects is more than the maximum number of mapped objects for the cycle time.	Set the number of objects to a value smaller than the maximum number of mapped objects for the cycle time.
				The cycle time setting is incorrect.	Correct the cycle time setting.
	05	RxPDO Setting Error	An RxPDO setting error was detected.	The RxPDO setting of EtherCAT master is incorrect.	Correct the RxPDO setting according to the definition of ESI of Servo Drive, and then download it to the EtherCAT master again. If this event occurs repeatedly after the download to the EtherCAT master, the Servo Drive is faulty. Replace the Servo Drive.
Servo Drive failure					
06	TxPDO Setting Error	A TxPDO setting error was detected.	The TxPDO setting of EtherCAT master is incorrect.	Correct the TxPDO setting according to the definition of ESI of Servo Drive, and then download it to the EtherCAT master again. If this event occurs repeatedly after the download to the EtherCAT master, the Servo Drive is faulty. Replace the Servo Drive.	
			Servo Drive failure		

Error No.		Name	Cause	Measures
Main (hex)	Sub (hex)			
90	07	RxPDO Mapping Error	<p>An incorrect RxPDO was set, such as out of the allowable range of Index, Subindex, or size. This error is detected when the following settings are made.</p> <ul style="list-style-type: none"> • If an object which cannot be mapped as a PDO is mapped • If the total size of objects mapped as the safety process data exceeds the specified size • If the total size of objects mapped to Sync Manager 2 PDO Assignment is one byte • If the total size of objects mapped as the variable PDOs exceeds the maximum size • If 1710 hex is not mapped while 1B10 hex is mapped (in 1B10 hex/1710 hex mapping) • If there were too many or too little data in 1710 hex • If the process data components were included in PDOs other than 1710 hex 	Correct the RxPDO setting, and then download it to the EtherCAT master again.
	08	TxPDO Mapping Error	<p>An incorrect TxPDO was set, such as out of the allowable range of Index, Subindex, or size. This error is detected when the following settings are made.</p> <ul style="list-style-type: none"> • If an object which cannot be mapped as a PDO is mapped • If the total size of objects mapped as the safety process data exceeds the specified size • If the total size of objects mapped to Sync Manager 3 PDO Assignment is one byte • If the total size of objects mapped as the variable PDOs exceeds the maximum size • If 1B10 hex is not mapped while 1710 hex is mapped (in 1710 hex/1B10 hex mapping) • If there were too many or too little data in 1B10 hex • If the process data components were included in PDOs other than 1B10 hex 	Correct the TxPDO setting, and then download it to the EtherCAT master again.
	09	Node Address Updated	The node address is changed from a set value in Sysmac Studio to a value of the ID switches.	Check the node address value. Set a correct value if it is wrong.

Error No.		Name	Cause		Measures
Main (hex)	Sub (hex)				
91	01	Command Error	A mistake was made in using a command.	When bit 9 (Remote) of the Statusword was set to 1 (remote), and the Servo Drive was in <i>Operation enabled</i> state (Servo ON), the Servo Drive received a command to change the communications state from Operational to another state (Init, Pre-Operational, or Safe-Operational).	Check the Servo Drive specifications and use the command correctly.
				A mode of operation other than the hm mode was set during the homing operation.	
				Modes of operation was set to pp, pv or hm mode when the communications period was set to shorter than 250 μ s.	
93	00	Electronic Gear Setting Error	The electronic gear ratio exceeded the allowable range. You can set the electronic gear ratio to the range from 1/2,000 to 2,000 times.		Correct the electronic gear ratio to the range from 1/2,000 to 2,000 times.
94	00	Function Setting Error	The function that was set does not support the communications period.	The electronic gear ratio was not 1:1 when the communications period was set to 125 μ s.	Correct the electronic gear ratio to 1:1, or set the communications period to longer than 125 μ s.
				The Backlash Compensation was enabled when the communications period was set to 125 μ s.	Disable the Backlash Compensation, or set the communications period to longer than 125 μ s.
95	01	Motor Non-conformity	The Servo Drive and motor combination is not correct.		Replace the motor with one that matches the Servo Drive.
	05	Motor Replacement Detected	The connected motor is different from the motor that was connected the last time.	The motor was replaced. The Servo Drive was replaced.	Perform the Motor Setup and Absolute Encoder Setup. Perform the Motor Setup.
97	00	Brake Interlock Error	The Brake Interlock Output (BKIR) was output by the Timeout at Servo OFF.	The Brake Interlock Output (BKIR) was output because the motor rotation speed did not decrease to or less than the speed set in the Threshold Speed at Servo OFF within the time set in the Timeout at Servo OFF when Servo OFF was performed during the motor operation.	Increase the set value of the Timeout at Servo OFF according to actual operation conditions.

Error No.		Name	Cause	Measures	
Main (hex)	Sub (hex)				
A0	00	Overload Warning	The load ratio of Servo Drive or motor (4150-81 hex) exceeded the level set in the Overload - Warning Notification Level .	Operation was continued for a long time with high load.	Perform the following corrections accordingly. <ul style="list-style-type: none"> • Increase the set value of the acceleration/deceleration time or the stop time. • Lighten the load. • Adjust the gain and inertia ratio. • If torque waveforms oscillate excessively, adjust the system by the tuning so that the oscillation does not occur. • Set the appropriate brake timing. • Increase the capacities of the Servo Drive and the motor.
				There is incorrect wiring of the motor cable or a broken cable.	<ul style="list-style-type: none"> • Connect the motor cable as shown in the wiring diagram. If the cable is broken, replace it. Or, connect the motor cable and encoder cable that are used together to the same motor. • Measure the voltage at the brake terminal. If the brake is applied, release it.
				Increase in friction	Check machine conditions and remove the cause of the friction.
A1	00	Regeneration Overload Warning	The Regeneration Load Ratio (4310-81 hex) exceeded 85% of the regeneration overload ratio.	The regeneration processing is set inappropriately.	Check the regeneration processing setting, and set the same value as the resistance value of the Regeneration Resistor in use.
				The Regeneration Resistor is selected inappropriately.	Check the operation pattern by the velocity monitor. Check the load ratio of Regeneration Resistor, and perform the following corrections accordingly. <ul style="list-style-type: none"> • Increase the deceleration time and stopping time. • Decrease the command velocity to the motor. • Use an External Regeneration Resistor. • Increase the capacities of the Servo Drive and the motor.
				This Regeneration Resistor is used for continuous regenerative braking.	The Regeneration Resistor cannot be used for continuous regenerative braking.
				The applied power supply voltage is higher than the specified value.	Apply the specified power supply voltage.
				Regeneration Resistor failure	Check whether the Regeneration Resistor is faulty, and use one without failures.

Error No.		Name	Cause	Measures	
Main (hex)	Sub (hex)				
A3	00	Fan Rotation Warning	The rotation speed of the fan is 80% or less of the rating and the cooling performance decreases.	There is a foreign matter in the cooling fan and it blocks the rotation.	Check whether there is a foreign matter in the fan. If you find a foreign matter, remove it.
				Cooling fan failure	If there is no improvement after you performed the correction above, replace the Servo Drive.
A4	00	Encoder Communications Warning	Encoder communications errors occurred in series more frequently than the specified value. This warning is detected if encoder communication fails twice in a row due to events such as a timeout or data error.	Noise into the encoder cable	<ul style="list-style-type: none"> Separate the motor cable and the encoder cable if they are bundled together. Connect the shield to FG. Check that the motor ground wire is connected to FG.
				Contact failure of the encoder cable	Check whether the connector is disconnected. Connect the connector firmly if it is disconnected or loose. Check that the encoder cable is not broken. Replace the encoder cable if it is broken.
				Power supply undervoltage to the encoder	Use the recommended encoder cable.
A6	00	Motor Vibration Warning	The motor vibration, which was higher than or equal to the level set in the Vibration Detection - Detection Level (3B70-01 hex), was detected.	The control parameter is set inappropriately.	Set the control parameters such as inertia ratio, gain, and filter to appropriate values by gain tuning or manually.
				The rigidity decreased due to mechanical looseness or wear.	Check whether the mechanical system is not loose and secure it firmly. If the rigidity of mechanical system is changed, adjust the control parameter again.

Error No.		Name	Cause		Measures
Main (hex)	Sub (hex)				
A7	01	Capacitor Lifetime Warning	The capacitor built into the Servo Drive reached the service life.	The operating time of the capacitor in the Servo Drive exceeded the service life.	Send the Servo Drive for repair or replace the Servo Drive with a new one. It is necessary to replace the component that reached the service life.
	02	Inrush Current Prevention Relay Lifetime Warning	The inrush current prevention relay built into the Servo Drive reached the service life.	The number of operating times of the inrush current prevention relay in the Servo Drive exceeded the service life.* ³	
	04	Brake Interlock Output Relay Lifetime Warning	The brake interlock output (BKIR) relay built into the Servo Drive reached the service life.	The number of operating times of the brake interlock output in the Servo Drive exceeded the service life.* ³	
	05	Lifetime Information Corruption Warning	An error was detected in the saved lifetime information.	The lifetime information corruption was detected when the power supply was turned ON.	Perform the Lifetime Information Clear. Note that the lifetime may not be detected correctly after the clear operation because the value of lifetime information is cleared. If this event occurs repeatedly, the area to save lifetime information is faulty. Replace the Servo Drive.
	06	Encoder Lifetime Warning	The encoder lifetime is close to the end.	Temporary noise	If this event occurs repeatedly, the lifetime is close to the end. Replace the motor.
		The end of the encoder life			
AB	00	Absolute Encoder Counter Overflow Warning	The multi-rotation counter of the encoder exceeded the value set in Encoder - Absolute Encoder Counter Overflow Warning Level (4510-02 hex).	An inappropriate value was set in the Encoder - Operation Selection when Using Absolute Encoder (4510-01 hex).	Set an appropriate value in the Encoder - Operation Selection when Using Absolute Encoder (4510-01 hex).
				The multi-rotation number of the encoder exceeded the warning level.	Set the travel distance so that the multi-rotation number does not exceed the value set in the Encoder - Absolute Encoder Counter Overflow Warning Level (4510-02 hex).
B0	00	Data Setting Warning	The object set value is out of the range.		Correct the object setting to be within the specified range.

Error No.		Name	Cause	Measures	
Main (hex)	Sub (hex)				
B1	00	Command Warning	A command could not be executed.	The <i>Switch on</i> command was received.	Send the <i>Switch on</i> command with the main circuit power supply ON.
				The <i>Enable operation</i> command was received.	Send the <i>Enable operation</i> command under the following conditions. <ul style="list-style-type: none"> • In supported operation mode • The motor rotation speed is 30 r/min or less. • In the free-run mode, the interpolation time period is the integral multiple of the communications cycle.
				An operation command in the prohibition direction was received after the immediate stop by the Drive Prohibition Input or Software Position Limit.	Check status of the Drive Prohibition Input and Software Position Limit by the Digital inputs, Statusword, and Software Position Limit. Then, do not issue the command in the drive prohibition direction.
				Homing started.	Set a supported number of the Homing method for homing. Start homing at the timing of when homing is not performed.
				The positioning start command was received in the Profile position mode.	Set a supported value for bit 5 and 6 in the Controlword.
B2	00	EtherCAT Communications Warning	An EtherCAT communications error occurred more than one time.	An EtherCAT communications cable has a contact failure, or is connected incorrectly or broken.	Connect the EtherCAT communications cable securely. If the cable is broken, replace it.
				Noise	Take noise countermeasures so that the noise does not affect the EtherCAT communications cable.
C0	00	STO Detected	The safety input OFF state was detected via the safety input signal or EtherCAT communications.	The cable is disconnected or broken.	Reconnect the input wiring for safety inputs 1 and 2. If the cable is broken, replace it.
				The STO input was turned OFF via EtherCAT communications.	Remove the cause that turned OFF the safety input signal of the Safety Input Unit.

*1. This error can occur in the unit version 1.2 or later.

*2. This error can occur in the unit version 1.1 or later.

*3. Refer to *AC Servomotors/Servo Drives 1S-series with Built-in EtherCAT® Communications User's Manual (I586)* for the lifetime of components.

7-5-2 Troubleshooting Using AL Status Codes

The AL status codes notify users of errors related to EtherCAT communications.

This section gives errors that 1S-series Servo Drives notify to the host controllers with AL status codes, as well as their causes and remedies.

AL Status Code List

AL status code (hex)	Name	Cause		Measures
0011	EtherCAT State Change Error	A communications state change command was received for which the current communications state could not be changed.		Check the command specifications for communications state transitions in the host controller and correct host controller processing.
0012	EtherCAT Illegal State Change Error	An undefined communications state change command was received.		Check the command specifications for communications state transitions in the host controller and correct host controller processing.
0013	Bootstrap State Transition Request Error	The state transition to unsupported Bootstrap was requested by the EtherCAT master.		Check the EtherCAT master setting so that the EtherCAT master does not request the transition to Bootstrap.
0014	SII Verification Error	An error occurred in SII data of the EtherCAT slave communications controller.	Data was incorrectly overwritten in the non-volatile memory of the EtherCAT slave communications controller.	If this event does not occur after you cycled the power supply, use the product continuously. It is supposed that a temporary error occurred due to a read error. If this event occurs again, replace the Servo Drive.
			Failure of the EtherCAT slave communications controller or false detection	
0016	Mailbox Setting Error	An incorrect mailbox setting of Sync Manager was detected.		Check the mailbox setting, and then download it to the EtherCAT master again.
001B	Sync Manager WDT Error	PDO communications were interrupted for the allowable period or longer.	An EtherCAT communications cable is disconnected, loose, or broken	Connect the EtherCAT communications cable securely.
			Host controller error	Check the operation of the host controller. Take appropriate countermeasures if there is a problem.
001D	RxPDO Setting Error	An RxPDO setting error was detected.	The RxPDO setting of EtherCAT master is incorrect.	Correct the RxPDO setting according to the definition of ESI of Servo Drive, and then download it to the EtherCAT master again.
			Servo Drive failure	If this event occurs repeatedly after the download to the EtherCAT master, the Servo Drive is faulty. Replace the Servo Drive.

AL status code (hex)	Name	Cause		Measures
001E	TxPDO Setting Error	A TxPDO setting error was detected.	The TxPDO setting of EtherCAT master is incorrect. Servo Drive failure	Correct the TxPDO setting according to the definition of ESI of Servo Drive, and then download it to the EtherCAT master again. If this event occurs repeatedly after the download to the EtherCAT master, the Servo Drive is faulty. Replace the Servo Drive.
001F	PDO WDT Setting Error	An incorrect PDO WDT setting was detected.		Check the PDO WDT setting, and then download it to the EtherCAT master again.
0024	TxPDO Mapping Error	<p>An incorrect TxPDO was set, such as out of the allowable range of Index, Subindex, or size.</p> <p>This error is detected when the following settings are made.</p> <ul style="list-style-type: none"> • If an object which cannot be mapped as a PDO is mapped • If the total size of objects mapped as the safety process data exceeds the specified size • If the total size of objects mapped to Sync Manager 3 PDO Assignment is one byte • If the total size of objects mapped as the variable PDOs exceeds the maximum size • If 1B10 hex is not mapped while 1710 hex is mapped (in 1710 hex/1B10 hex mapping) • If there were too many or too little data in 1B10 hex • If the process data components were included in PDOs other than 1B10 hex 		Correct the TxPDO setting, and then download it to the EtherCAT master again.
0025	RxPDO Mapping Error	<p>An incorrect RxPDO was set, such as out of the allowable range of Index, Subindex, or size.</p> <p>This error is detected when the following settings are made.</p> <ul style="list-style-type: none"> • If an object which cannot be mapped as a PDO is mapped • If the total size of objects mapped as the safety process data exceeds the specified size • If the total size of objects mapped to Sync Manager 2 PDO Assignment is one byte • If the total size of objects mapped as the variable PDOs exceeds the maximum size • If 1710 hex is not mapped while 1B10 hex is mapped (in 1B10 hex/1710 hex mapping) • If there were too many or too little data in 1710 hex • If the process data components were included in PDOs other than 1710 hex 		Correct the RxPDO setting, and then download it to the EtherCAT master again.
0028	SM Event Mode Setting Error	The unsupported SM Event Mode was set.		Check the synchronization setting, and then download it to the EtherCAT master again.

AL status code (hex)	Name	Cause		Measures
002C	Synchronization Error	A signal for synchronous communications could not be detected.	Noise	Take noise countermeasures if excessive noise affects the EtherCAT communications cable.
			Error of the EtherCAT slave communications controller	If this event occurs again after you cycled the power supply, replace the Servo Drive.
002D	Synchronization Interruption Error	Synchronization interruption did not occur within the specified period.	Incorrect EtherCAT synchronization setting of the host controller.	Set the synchronization setting of the host controller according to the synchronization specifications for the EtherCAT slave.
			Failure of the EtherCAT slave communications controller or false detection	If this event does not occur after you cycled the power supply, use the product continuously. It is supposed that a temporary error occurred due to a read error. If this event occurs again, the Servo Drive is faulty. Replace the Servo Drive.
0030	DC Setting Error	A mistake was made in the DC Mode operation setting.		Check the DC Mode setting, and then download it to the EtherCAT master again.
0034	Communications Synchronization Error	Communications were not established consecutively because the synchronization with the EtherCAT Master could not be achieved.	The power supply to the host controller was interrupted during PDO communications.	Reset the error in the host controller. This event reports an error that was detected when the power supply to the host controller was interrupted. It does not indicate that an error currently exists.
			An EtherCAT communications cable is disconnected, loose, broken, or has a contact failure.	Connect the EtherCAT communications cable securely. If the cable is broken, replace it.
			Noise	Take noise countermeasures if excessive noise affects the EtherCAT communications cable.
0035	Synchronization Cycle Setting Error	When the DC mode was established, the cycle time was set to the inoperable value. In the variable PDO mapping, the maximum number of objects you can map is specified as follows: 6 for both RxPDO and TxPDO for the communication period of 125 μ s, 10 for both RxPDO and TxPDO for other communication periods. An error occurs if you map a larger number of objects than that specified above. This error is also detected in the following case: the cycle time is an integral multiple of 125 μ s and is not 10 ms or lower.	The variable PDO mapping is used, and the number of objects is more than the maximum number of mapped objects for the cycle time.	Set the number of objects to a value smaller than the maximum number of mapped objects for the cycle time.
			The cycle time setting is incorrect.	Correct the cycle time setting.

AL status code (hex)	Name	Cause		Measures
0050	ESC Error	An error occurred in the EtherCAT slave communications controller.	Error access from the non-OMRON EtherCAT master	Please contact the manufacturer of EtherCAT master.
0051			Error of the EtherCAT slave communications controller or false detection	If this event occurs repeatedly after you cycled the power supply, the EtherCAT slave communications controller is faulty. Replace the Servo Drive.
0061	Node Address Updated	The node address is changed to a value of the ID switches.		Check the node address value. Set a correct value if it is wrong.
		The node address is changed from a set value in Sysmac Studio to a value of the ID switches.		
8000	Unit Restarted	Restart was performed.		---

7-5-3 Troubleshooting Using the Operation State

Symptom	Probable cause	Check items	Measures
The 7-segment display does not light.	The control power is not supplied.	Check to see if the power supply input is within the allowed power supply voltage range.	Supply the correct power supply voltage.
		Check to see if the power supply input is wired correctly.	Wire correctly.
The ECAT ERR indicator flashes or lights.	A communications-related error occurred.	Refer to <i>EtherCAT Communications Warning</i> on page 7-9.	
The L/A IN and L/A OUT indicators are OFF.	A link in the EtherCAT physical communications layer is not established.	Check to see if the communications cable is connected correctly.	Connect the communications cable correctly.
		Check to see if the host controller started.	Start the host controller.
An error occurred.	Read the error number and the error log.	Check the cause listed in 7-5-1 <i>Troubleshooting Using Error Displays</i> on page 7-14.	
The Servo does not lock.	The power cable is not connected correctly.	Check to see if the motor power cable is connected properly.	Wire the motor power cable correctly.
	The Servomotor power supply is not ON.	Check the main circuit wiring and power voltage.	Input the correct power and voltage for the main circuit.
	Positive Drive Prohibition Input (POT) or Negative Drive Prohibition Input (NOT) is OFF.	<ul style="list-style-type: none"> Check to see if the input for POT or NOT is OFF. Check the input of +24 VIN to CN1. 	Turn ON POT and NOT. Input +24 VIN correctly.
	The torque limit is set to 0.	Check to see if the torque limits in the Positive torque limit value (60E0 hex) and the Negative torque limit value (60E1 hex) are set to 0.	Set the maximum torque that you use for each of these objects.
	The Servo Drive is in a safe state (STO).	Check the wiring of the safety input.	Wire correctly.
	Communications with the Safety CPU Unit are not established.	When you use the STO function via EtherCAT communications, confirm that communications with the Safety CPU Unit are performed.	Make the settings for the Safety CPU Unit.
	The Servo Drive is broken down.	---	Replace the Servo Drive.

Symptom	Probable cause	Check items	Measures
The Servo locks but the Servomotor does not rotate.	The host controller does not give a command.	For a position command, check to see if the speed and position are set to 0.	Enter position and speed data. Start the Servomotor.
	The Servo Drive received a command but it is not accepted.	Check to see if the Servo Drive retains the object value for two communications cycles or more in Profile position mode (pp).	Set the Servo Drive so that it retains the object value for two communications cycles or more.
	It is hard to determine if the Servomotor is rotating.	Check to see if the velocity command given by the host controller is too small.	Check the velocity command from the host controller.
	The holding brake is operating.	Check the Brake Interlock Output (BKIR) signal and the +24 VDC power supply.	Check to see if the holding brake on a Servomotor with brake is released when the Servo is locked.
	The torque limits set in the Positive torque limit value (60E0 hex) and the Negative torque limit value (60E1 hex) are too small.	Check to see if the torque limits in objects 60E0 hex and 60E1 hex are set to a value close to 0.	Set the maximum torque that you use for each of these objects.
	Positive Drive Prohibition Input (POT) or Negative Drive Prohibition Input (NOT) is OFF.	Check the ON/OFF state of the POT and NOT signals from the Sysmac Studio.	<ul style="list-style-type: none"> • Turn ON the POT and NOT signals. • Disable them in the settings when the POT and NOT signals are not used.
	The motor power cable is wired incorrectly.	Check the wiring.	Wire correctly.
	The encoder cable is wired incorrectly.		
	Power is not supplied.	Check the power supply and the 7-segment display.	Turn ON the power.
Check the voltage between the power terminals.		Wire the power-ON circuit correctly.	
The Servo Drive is broken down.	---	Replace the Servo Drive.	
The Servomotor operates momentarily, but then it does not operate after that.	The position commands given are too little.	Check the position data and the electronic gear ratio at the host controller.	Set the correct data.
	The motor power cable is wired incorrectly.	Check the wiring of the motor power cable's phases U, V, and W.	Wire correctly.
	The encoder cable is wired incorrectly.	Check the encoder cable's wiring.	Wire correctly.
The Servomotor rotates without a command.	There are inputs of small values in velocity control mode.	Check if there is an input in velocity control mode.	Set the velocity command to 0. Alternatively, change the mode to position control mode.
	The motor power cable is wired incorrectly.	Check the wiring.	Wire correctly.
When the runaway detection function is enabled, the Servomotor rotates without a command.	The Servomotor power cable is wired incorrectly, and conditions under which the runaway detection function cannot work are satisfied.	Check the wiring.	Wire correctly.

Symptom	Probable cause	Check items	Measures
The Servomotor rotates in the reverse direction from the command.	The value set in Motor Rotation Direction Selection (3000-01 hex) is incorrect.	Check the value of Motor Rotation Direction Selection .	Change the value of Motor Rotation Direction Selection .
	The command given by the host controller is incorrect.	<ul style="list-style-type: none"> The size of the absolute command is set incorrect. The polarity of an incremental command is set incorrect. 	<ul style="list-style-type: none"> Check the actual and target values. Check the rotation direction.
	The Servomotor power cable is wired incorrectly.	Check the wiring.	Wire correctly.
When the runaway detection function is enabled, the Servomotor rotates in the reverse direction from the command.	The value set in Motor Rotation Direction Selection (3000-01 hex) is incorrect.	Check the value of Motor Rotation Direction Selection .	Change the value of Motor Rotation Direction Selection .
	The command given by the host controller is incorrect.	<ul style="list-style-type: none"> The size of the absolute command is set incorrect. The polarity of an incremental command is set incorrect. 	<ul style="list-style-type: none"> Check the actual and target values. Check the rotation direction.
	The Servomotor power cable is wired incorrectly.	Check the wiring.	Wire correctly.
	The Servomotor power cable is wired incorrectly, and conditions under which the runaway detection function cannot work are satisfied.		
The holding brake does not work.	Power is supplied to the holding brake.	Check to see if power is supplied to the holding brake.	<ul style="list-style-type: none"> Check the Brake Interlock Output (BKIR) signal and the relay circuit. Check to see if the holding brake is worn down.
Motor rotation is unstable.	The motor power cable or encoder cable is wired incorrectly.	Check the wiring of the motor power cable's phases U, V, W and check the encoder cable's wiring.	Wire correctly.
	Low rigidity is causing vibration.	Measure the vibration frequency of the load.	Enable the damping control. Set the damping filter frequency.
	The load's moment of inertia exceeds the Servo Drive's allowable value.	Calculate the load inertia.	<ul style="list-style-type: none"> Check if manual tuning can achieve proper adjustment. Increase the Servomotor capacity.
	Loose joint and/or large clearance with the machine.	Check the joint with the machine.	Remove the joint looseness with the machine.
	The load and gain do not match.	Check the response waveforms for speed and torque.	Perform the tuning again to stabilize the rotation.

Symptom	Probable cause	Check items	Measures
The Servomotor is overheating.	The ambient temperature is too high.	Check to see if the ambient temperature around the Servomotor is over 40°C.	<ul style="list-style-type: none"> Lower the ambient temperature around the Servomotor to 40°C or less. (Use a fan or air conditioner.) Lower the load ratio.
	The heat radiation condition for the Servomotor is inappropriate.	<ul style="list-style-type: none"> Check to see if the specified radiation conditions are observed. For a Servomotor with a brake, check the load ratio. 	<ul style="list-style-type: none"> Improve the radiation conditions. Reduce the load. Improve ventilation.
	The Servomotor is overloaded. The Servomotor vibrates during rotation.	Check the torque with the Sysmac Studio.	<ul style="list-style-type: none"> Decrease the acceleration and deceleration rates. Lower the speed and check the load.
The machine position is misaligned.	The coupling of the motor shaft and the machine is abnormal.	Check to see if the coupling of the Servomotor and the machine is misaligned.	<ul style="list-style-type: none"> Tighten the coupling again. Replace the coupling with a coupling that has no looseness.
	The host controller gave a deceleration stop command.	Check the control ladder program in the host controller.	Review the control in the host controller.
	The gain is wrong.	---	Check if manual tuning can achieve proper adjustment.
	The load inertia is too large.	<ul style="list-style-type: none"> Check the load inertia. Check the Servomotor rotation speed. 	<ul style="list-style-type: none"> Review the load inertia. Replace the Servomotor and Servo Drive with proper ones.
	The power supply was turned ON while the encoder multi-rotation exceeded the limit value.	Check Encoder - Multi-rotation Data .	Perform the operation within the multi-rotation range.
	The command value from the host controller is not correct.	Check the control ladder program and settings in the host controller.	Review the control and settings in the host controller.
	The home position was shifted.	<ul style="list-style-type: none"> Check the home position of the absolute encoder. Check whether homing is performed normally. 	<ul style="list-style-type: none"> Adjust the mechanical home and home position of the absolute encoder. Change the setting or input signals so that the correct home position can be defined during homing.
	The set values of the Servo Drive do not match the machine.	Check the settings of gear ratio, gain, maximum torque, etc.	Adjust the set values so that they match the machine.
The Servomotor does not stop or is hard to stop even if the Servo is turned OFF while the Servomotor is rotating.	The load inertia is too large.	<ul style="list-style-type: none"> Check the load inertia. Check the Servomotor rotation speed. 	<ul style="list-style-type: none"> Review the load inertia. Replace the Servomotor and Servo Drive with proper ones.
	The dynamic brake is disabled.	Check if the dynamic brake is disabled or broken.	<ul style="list-style-type: none"> Enable the dynamic brake, if it is disabled. Replace the dynamic brake if it is broken.

Symptom	Probable cause	Check items	Measures
The Servomotor or the load generates abnormal noise or vibration.	Vibration occurs due to improper mechanical installation.	Check to see if the Servomotor's mounting screws are loose.	Retighten the mounting screws.
		Check the load for eccentricity.	Eliminate the eccentricity. It results in torque fluctuation and noise.
		Check to see if the coupling with the load is unbalanced.	Balance the rotation.
		Check to see if the decelerator is generating any abnormal noise.	Check the decelerator specifications. Check the decelerator for malfunctions.
Vibration occurs due to low mechanical rigidity.	Check to see if the vibration frequency is 100 Hz or lower.	If the frequency is 100 Hz or lower, set the correct damping frequency for the damping filter to eliminate the vibration.	
Vibration occurs due to machine resonance.	Check to see if the resonance frequency is high or low.	If the resonance frequency is high, set the adaptive filter to eliminate the resonance. Alternatively, measure the resonance frequency and set 1st Notch Filter and 2nd Notch Filter.	
There is a problem with the bearings.	Check for noise or vibration around the bearings.	Check to see if the bearings are mounted properly, and adjust them if necessary.	
The gain is too high.	---	Use the Sysmac Studio to measure the response and adjust the gain.	
Velocity Command Filter (3021 hex) is wrong.	Check the set value of Velocity Command Filter .	Return the setting to the default value of 0. Alternatively, set a large value and operate the Servomotor.	

Symptom	Probable cause	Check items	Measures
The Servomotor or the load generates abnormal noise or vibration.	1st Torque Command Filter (3233 hex) or 2nd Torque Command Filter (3234 hex) does not match the load.	Review the set value of the torque command filter.	Set a small value for the torque command filter to eliminate the vibration.
	1st Position Control Gain (3213 hex) or 2nd Position Control Gain (3214 hex) is too large.	Review the setting of the position control gain.	Use the Sysmac Studio to measure the response and adjust the gain.
	Proportional Gain and Integral Gain in 1st Velocity Control Gain (3223 hex) and 2nd Velocity Control Gain (3224 hex) are balanced incorrectly.	Review the set values of the velocity control gain.	
	Noise is entering into the control I/O signal cable because the cable is longer than the specified length.	Check the length of the control I/O signal cable.	Shorten the control I/O signal cable to 3 m or less.
	Noise is entering into the cable because the encoder cable does not meet specifications.	Check to see if it is a shielded twisted-pair cable with core wires that are at least 0.12 mm ² .	Use an encoder cable that meets specifications.
	Noise is entering into the encoder cable because the cable is longer than the specified length.	Check the length of the encoder cable.	Shorten the encoder cable to less than 50 m.
	Noise is entering into the signal lines because the encoder cable is stuck or the sheath is damaged.	Check the encoder cable for damage.	Correct the encoder cable's pathway.
	Excessive noise on encoder cable.	Check to see if the encoder cable is bound together with or too close to high-current lines.	Install the encoder cable where it won't be subjected to surges.
	The FG's potential is fluctuating due to devices near the Servomotor, such as welding machines.	Check for ground problems (loss of ground or incomplete ground) at equipment such as welding machines near the Servomotor.	Ground the equipment properly and prevent current from flowing to the encoder FG.
	Errors are caused by excessive vibration or shock on the encoder.	There are problems with mechanical vibration or Servomotor installation (such as the precision of the mounting surface, attachment, or axial offset).	Reduce the mechanical vibration or correct the Servomotor's installation.
Overshooting at startup or when stopping	1st Position Control Gain (3213 hex) or 2nd Position Control Gain (3214 hex) is too large.	Review the setting of the position control gain.	Use the Sysmac Studio to measure the response and adjust the gain.
	Proportional Gain and Integral Gain in 1st Velocity Control Gain (3223 hex) and 2nd Velocity Control Gain (3224 hex) are balanced incorrectly.	Review the set values of the velocity control gain.	
	The set inertia ratio differs from the load.	Review the set value of the Inertia Ratio (3001-01 hex).	Adjust the set value of the Inertia Ratio.

Symptom	Probable cause	Check items	Measures
Vibration is occurring at the same frequency as the power supply.	Inductive noise is occurring.	Check to see if the drive control signal lines are too long.	Shorten the control signal lines.
		Check to see if the control signal lines and power supply lines are bound together.	<ul style="list-style-type: none"> • Separate control signal lines from power supply lines. • Use a low-impedance power supply for control signals.
The command velocity or torque is not reached.	The input command value exceeds the velocity limit value or the torque limit value.	Check to see if the Internal limit active bit of Statusword is active.	Input the command value that does not exceed the velocity limit value or the torque limit value from the host controller.

8

Maintenance and Inspection

This section explains maintenance and inspection of the Servomotors and Servo Drives.

8-1	Periodic Maintenance	8-2
8-2	Servo Drive Lifetime	8-3
8-3	Servomotor Lifetime	8-4

8-1 Periodic Maintenance



Caution

After replacing the Servo Drive, transfer to the new Servo Drive all data needed to resume operation, before restarting operation. Equipment damage may result.



Do not repair the Servo Drive by disassembling it. Electric shock or injury may result.



Servomotors and Servo Drives contain many components and will operate properly only when each of the individual components is operating properly.

Some of the electrical and mechanical components require maintenance depending on application conditions. Periodic inspection and replacement are necessary to ensure proper long-term operation of Servomotors and Servo Drives. (Quoted from *The Recommendation for Periodic Maintenance of a General-purpose Inverter* published by JEMA.)

The periodic maintenance cycle depends on the installation environment and application conditions of the Servomotors and Servo Drives.

Recommended maintenance times are given below for Servomotors and Servo Drives. Use these for reference in periodic maintenance.

8-2 Servo Drive Lifetime

- The lifetime of Servo Drive depends on application conditions. When the ambient temperature is 40°C and the average output is 70% of the rated output, the design life expectancy is ten years.
- The use of the Servo Drive in a hot environment shortens its lifetime. We recommend that the ambient temperature and the power supply ON time be reduced as much as possible to lengthen the lifetime of the Servo Drive.
- The lifetimes for the different parts of Servo Drive are given below.

Name	Lifetime
Inrush current prevention relay	Approx. 36,500 operations (lifetime depends on application conditions.)
Brake interlock output relay	Approx. 36,500 operations (lifetime depends on application conditions.)

8-3 Servomotor Lifetime

The lifetimes for the different motor parts are listed below.

Name	Lifetime
Bearing	20,000 hours
Decelerator ^{*1}	20,000 hours
Oil seal ^{*1}	5,000 hours (models with oil seal) ^{*1}
Brake	ON/OFF 1,000,000 times

*1. These parts are not included in the Incremental Encoder Type Servomotors.

The operating conditions are determined as follows.

- Operating ambient temperature: 40°C
- Within the range of allowable axial load
- Rated operation (rated torque and rated rotation speed)
- Installation as specified in this manual
- Operation is not repeated with the motor shaft rotation at an angle of 45° or less, which causes the fretting.

Oil seal can be replaced for repair.

When the Servomotor is used for a belt hook such as timing pulley, the radial load during motor operation is generally two or more times the static load. Consult with the belt and pulley manufacturers to adjust designs and system settings so that the motor allowable axial load is not exceeded even during operation. If the Servomotor is used under a shaft load that exceeds the allowable limit, the motor shaft can be broken and the bearings can be damaged.



Additional Information

If the Encoder Lifetime Warning occurs, we recommend you to replace the encoder within a few weeks.



Appendices

The appendices provide explanation for the profile that is used to control the Servo Drive, lists of objects, and Sysmac error status codes.

A-1	Sysmac Error Status Codes	A-2
A-1-1	Error List	A-2
A-1-2	Error Descriptions	A-14

A-1 Sysmac Error Status Codes

This section lists and describes the error event codes that you can see in Sysmac Studio.

A-1-1 Error List

The errors (events) that can occur in 1S-series AC Servo Drives with Built-in EtherCAT Communications are given on the following pages.

Event levels are given in the table as follows:

Min: Minor fault level

Obs: Observation

Info: Information

Refer to the *NJ/NX-series Troubleshooting Manual* (Cat. No. W503) for all of the event codes that may occur in an NJ/NX-series Controller.

Event code (hex)	Event name	Description	Assumed cause	Level			Reference
				Min	Obs	Info	
04B30000	Regeneration Circuit Error Detected during Power ON*1	An error of the Regeneration Circuit was detected at power ON.	<ul style="list-style-type: none"> Power supply voltage is insufficient at power ON, or rising slowly. Power supply voltage fluctuated at power ON. L1, L2, and L3 terminals are not connected or disconnected. N1 and N2 terminals are opened. Servo Drive failure. 	√			P. A-15
05430000	ESC Error	An error occurred in the EtherCAT slave communications controller.	<ul style="list-style-type: none"> Error of the EtherCAT slave communications controller or false detection when the AL status code is 0051 hex Error access from the non-OMRON EtherCAT master when the AL status code is 0050 hex 	√			P. A-17
08390000	Power Module Error	An error was detected in the power module.	<ul style="list-style-type: none"> There is a short-circuit, ground fault, or contact failure on the U, V, or W motor cable There is a short-circuit on the wiring of External Regeneration Resistor or the resistance value is small The insulation resistance failed between the U, V, or W motor cable and the motor ground wire Servo Drive failure 	√			P. A-18

Event code (hex)	Event name	Description	Assumed cause	Level			Reference
				Min	Obs	Info	
083B0000	Self-diagnosis Error	An error was detected by the self-diagnosis of the safety function.	<ul style="list-style-type: none"> False detection due to a data read error that was caused by excessive noise Hardware failure 	√			P. A-19
083C0000	Main Circuit Temperature Monitoring Circuit Failure	A temperature monitoring circuit failure was detected on the main circuit.	<ul style="list-style-type: none"> Broken wiring of the thermistor, temperature monitoring circuit failure 	√			P. A-19
083D0000	Fan Error	The rotation speed of the fan is 40% or less of the rating and the cooling performance decreases.	<ul style="list-style-type: none"> There is a foreign matter in the cooling fan and it blocks the rotation Cooling fan failure 	√			P. A-20
083F0000	Regeneration Processing Error	The regeneration processing was stopped to protect the Regeneration Resistor.	<ul style="list-style-type: none"> The regeneration processing is set inappropriately The Regeneration Resistor is selected inappropriately The Regeneration Resistor is used for continuous regenerative braking The applied power supply voltage is higher than the specified value Regeneration Resistor failure 	√			P. A-21
08410000	Overspeed Error	The main circuit power supply voltage (P-N voltage) exceeded the operation guarantee range.	<ul style="list-style-type: none"> The P-N voltage exceeded the specified value The input voltage increased The Regeneration Resistor wiring is broken The External Regeneration Resistor is set or selected inappropriately Servo Drive failure 	√			P. A-22
08420000	Motor Overheat Error	The encoder detected the temperature that exceeded the protection level of motor.	<ul style="list-style-type: none"> The temperature is high around the motor The motor is overloaded Encoder failure 	√			P. A-23
08430000	1-rotation Counter Error	The encoder detected a one-rotation counter error.	<ul style="list-style-type: none"> There is excessive noise Failure due to vibration, impact, condensation, foreign matter, etc. 	√			P. A-23
08440000	Overspeed Error	The encoder detected the overspeed.	<ul style="list-style-type: none"> The motor was rotated by external forces Encoder failure and false detection 	√			P. A-24
08450000	Encoder Memory Error	The encoder detected a non-volatile memory error.	<ul style="list-style-type: none"> False detection due to a data read error that was caused by excessive noise Non-volatile memory failure 	√			P. A-24

Event code (hex)	Event name	Description	Assumed cause	Level			Reference
				Min	Obs	Info	
08460000	Absolute Position Detection Error	The encoder detected a multi-rotation counter error.	<ul style="list-style-type: none"> A detection error was detected in the multi-rotation detection section of the encoder There is excessive noise 	√			P. A-25
08480000	Main Power Supply Undervoltage (insufficient voltage between P and N)	The main circuit power supply voltage fell below the operation guarantee range during Servo ON.	<ul style="list-style-type: none"> Incorrect wiring of the main circuit power supply The low power supply voltage is applied to the Servo Drive The long time was set in Momentary Hold Time and the voltage was decreased momentarily Servo Drive failure 	√			P. A-26
08490000	Overcurrent Error	The current flowing to the motor exceeded the protection level.	<ul style="list-style-type: none"> There is a short-circuit, ground fault, or contact failure on the U, V, or W motor cable There is a short-circuit on the wiring of External Regeneration Resistor The insulation resistance failed between the U, V, or W motor cable and the motor ground wire False detection due to the noise Servo Drive failure 	√			P. A-27
084A0000	Encoder Communications Disconnection Error	The communications disconnection was detected between the encoder and the Servo Drive.	<ul style="list-style-type: none"> Noise into the encoder cable Contact failure of the signal line, and disconnection of the encoder Power supply undervoltage to the encoder Encoder failure 	√			P. A-28
084B0000	Encoder Communications Error	Illegal data was received from the encoder the specified number of times.	<ul style="list-style-type: none"> Noise into the encoder cable Contact failure of the signal line, and disconnection of the encoder Power supply undervoltage to the encoder 	√			P. A-29
084D0000	Non-volatile Memory Hardware Error	An error occurred on the non-volatile memory.	<ul style="list-style-type: none"> False detection due to a data read error that was caused by excessive noise Non-volatile memory failure 	√			P. A-30

Event code (hex)	Event name	Description	Assumed cause	Level			Reference
				Min	Obs	Info	
18230000	Absolute Encoder Multi-rotation Counter Error	The encoder detected a multi-rotation counter error.	<ul style="list-style-type: none"> A temporary error occurred in the encoder multi-rotation detection function due to vibration, impact, or condensation Encoder failure 	√			P. A-30
18380000	System Error	A hardware error due to the self-diagnosis and a fatal software error were detected.	<ul style="list-style-type: none"> False detection due to a data read error that was caused by excessive noise A fatal software error was detected Hardware failure 	√			P. A-31
183A0000	Non-volatile Memory Data Error	An error of data saved in the non-volatile memory was detected.	<ul style="list-style-type: none"> Power interruption or noise occurred while parameters other than the safety were saved Power interruption or noise occurred while the motor identity information was saved Power interruption or noise occurred while safety parameters were saved 	√			P. A-31
246D0000	Motor Non-conformity	The Servo Drive and motor combination is not correct.	<ul style="list-style-type: none"> The Servo Drive and motor combination is not correct 	√			P. A-32
28080000	Main Circuit Power Supply Phase Loss Error	The phase loss of the main circuit power supply was detected	<ul style="list-style-type: none"> Incorrect wiring, for example the single-phase power supply is input to a 3-phase input type Servo Drive In the case where the single-phase power supply is input to a single- and 3-phase input type Servo Drive, the phase loss detection is enabled. The power supply voltage is low or insufficient Broken wiring of the main circuit power supply input Servo Drive failure 	√			P. A-33
280D0000	Runaway Detected ^{*2}	The motor rotated in the direction opposite to the command.	<ul style="list-style-type: none"> There is incorrect wiring of the motor cable or a broken cable. The motor rotated in the direction opposite to the command by external forces. 	√			P. A-34
357D0000	DC Setting Error	A mistake was made in the DC Mode operation setting.	<ul style="list-style-type: none"> A mistake was made in the DC Mode operation setting 	√			P. A-35

Event code (hex)	Event name	Description	Assumed cause	Level			Reference
				Min	Obs	Info	
357E0000	Synchronization Cycle Setting Error	When the DC mode was established, the cycle time was set to the inoperable value.	<ul style="list-style-type: none"> The variable PDO mapping is used, and the number of objects is more than the maximum number of mapped objects for the cycle time The cycle time setting is incorrect 	√			P. A-35
357F0000	Mailbox Setting Error	An incorrect mailbox setting of Sync Manager was detected.	<ul style="list-style-type: none"> An incorrect mailbox setting of Sync Manager was detected 	√			P. A-36
35800000	RxPDO Setting Error	An RxPDO setting error was detected.	<ul style="list-style-type: none"> The RxPDO setting of EtherCAT master is incorrect Servo Drive failure 	√			P. A-36
35810000	TxPDO Setting Error	A TxPDO setting error was detected.	<ul style="list-style-type: none"> The TxPDO setting of EtherCAT master is incorrect Servo Drive failure 	√			P. A-37
35820000	RxPDO Mapping Error	An incorrect RxPDO was set.	<ul style="list-style-type: none"> An incorrect RxPDO was set, such as out of the allowable range of Index, Subindex, or size 	√			P. A-37
35830000	TxPDO Mapping Error	An incorrect TxPDO was set.	<ul style="list-style-type: none"> An incorrect RxPDO was set, such as out of the allowable range of Index, Subindex, or size 	√			P. A-38
35840000	PDO WDT Setting Error	An incorrect PDO WDT setting was detected.	<ul style="list-style-type: none"> An incorrect PDO WDT setting was detected 	√			P. A-38
35850000	Node Address Updated	The node address is changed to a value of the ID switches.	<ul style="list-style-type: none"> The node address is changed from a set value in Sysmac Studio to a value of the ID switches 	√			P. A-39
35860000	SM Event Mode Setting Error	The unsupported SM Event Mode was set.	<ul style="list-style-type: none"> The unsupported SM Event Mode was set 	√			P. A-39
38570000	Function Setting Error	The function that was set does not support the communications period.	<ul style="list-style-type: none"> The electronic gear ratio was not 1:1 when the communications period was set to 125 μs. The Backlash Compensation was enabled when the communications period was set to 125 μs. 	√			P. A-40
38780000	General Input Allocation Duplicate Error	More than one function input is allocated to one general input.	<ul style="list-style-type: none"> More than one function input is allocated to one general input 	√			P. A-41
38790000	General Output Allocation Duplicate Error	More than one function output is allocated to one general output.	<ul style="list-style-type: none"> More than one function output is allocated to one general output 	√			P. A-41
387B0000	Pulse Output Setting Error	The dividing numerator exceeded the dividing denominator when the Encoder Dividing Pulse Output - Dividing Denominator was set to a value other than 0.	<ul style="list-style-type: none"> The dividing numerator exceeded the dividing denominator when the Encoder Dividing Pulse Output - Dividing Denominator was set to a value other than 0 	√			P. A-42

Event code (hex)	Event name	Description	Assumed cause	Level			Reference
				Min	Obs	Info	
387C0000	Motor Replacement Detected	The connected motor is different from the motor that was connected the last time.	<ul style="list-style-type: none"> The motor was replaced The Servo Drive was replaced 	√			P. A-42
387F0000	Electronic Gear Setting Error	The electronic gear ratio exceeded the allowable range.	<ul style="list-style-type: none"> The electronic gear ratio exceeded the allowable range 	√			P. A-43
38800000	Servo Drive Overheat	The internal temperature of Servo Drive exceeded the circuit protection level.	<ul style="list-style-type: none"> The ambient temperature of the Servo Drive exceeded the specified value Overload 	√			P. A-43
38810000	Overload Error	The Load Ratio of Servo Drive or motor (4150-81 hex) exceeded 100%.	<ul style="list-style-type: none"> Operation was continued for a long time with high load There is incorrect wiring of the motor cable or a broken cable Increase in friction 	√			P. A-44
38820000	Regeneration Overload Error	The Regeneration Load Ratio (4310-81 hex) exceeded the regeneration overload ratio.	<ul style="list-style-type: none"> The regeneration processing is set inappropriately The Regeneration Resistor is selected inappropriately The Regeneration Resistor is used for continuous regenerative braking The applied power supply voltage is higher than the specified value Regeneration Resistor failure 	√			P. A-45
38830000	Excessive Position Deviation Error	The position deviation is greater than or equal to the value set in the Following error window.	<ul style="list-style-type: none"> The motor operation does not follow the command The value of Following error window is small 	√			P. A-46
38840000	Excessive Speed Deviation Error	The speed deviation is greater than or equal to the value set in the Excessive Velocity Deviation Detection Level.	<ul style="list-style-type: none"> The motor operation does not follow the command because a parameter value is inappropriate The output axis of motor is limited on the operation by external forces The value of the Excessive Velocity Deviation Detection Level is inappropriate 	√			P. A-47
38850000	Excessive Speed Error	The feedback motor speed is greater than or equal to the value set in the Excessive Speed Detection Level.	<ul style="list-style-type: none"> The velocity command value is too large Overshooting occurred The motor was rotated by external forces 	√			P. A-48

Event code (hex)	Event name	Description	Assumed cause	Level			Reference
				Min	Obs	Info	
38860000	Following Error Counter Overflow	The following error value exceeded the range from -2147483648 to 2147483647.	<ul style="list-style-type: none"> The motor operation does not follow the command The motor is rotated or limited on the operation by external forces 	√			P. A-49
38870000	Absolute Encoder Counter Overflow Error	The multi-rotation counter of the encoder exceeded the maximum number of rotations.	<ul style="list-style-type: none"> An inappropriate value was set in the Encoder - Operation Selection when Using Absolute Encoder (4510-01 hex) The multi-rotation number of the encoder exceeded the maximum number of rotations 	√			P. A-49
38880000	Safety Communications Setting Error	Safety process data communications were not established with the Safety CPU Unit because of an incorrect communications setting.	<ul style="list-style-type: none"> The watchdog time was set incorrectly The processing was not completed within the watchdog time because communications were not established due to the noise 	√			P. A-50
38890000	Safety Frame Error	Safety process data communications were not established with the Safety CPU Unit because an incorrect frame was received.	<ul style="list-style-type: none"> An incorrect frame was received in safety process data communications There is excessive noise 	√			P. A-51
388A0000	Safety Parameter Error	Safety process data communications were not established with the Safety CPU Unit because an incorrect parameter was received.	<ul style="list-style-type: none"> The set safety slave model is incorrect 	√			P. A-51
388B0000	FSoE Slave Address Error	Safety process data communications were not established with the Safety CPU Unit because of an incorrect FSoE slave address.	<ul style="list-style-type: none"> The setting of the FSoE slave address in the safety process data communications settings is different from the setting in the Unit 	√			P. A-52
48080000	FPGA WDT Error	An FPGA error was detected.	<ul style="list-style-type: none"> False detection due to a data read error that was caused by excessive noise Hardware failure 	√			P. A-52
64E30000	Drive Prohibition Input Error	Both the Positive Drive Prohibition (POT) and the Negative Drive Prohibition Input (NOT) turned ON.	<ul style="list-style-type: none"> An error occurred on the switch, wire, power supply, and wiring that were connected to the Positive Drive Prohibition (POT) or Negative Drive Prohibition Input (NOT) False detection occurred because the control signal power supply was turned ON slowly 	√			P. A-53

Event code (hex)	Event name	Description	Assumed cause	Level			Reference
				Min	Obs	Info	
68200000	Drive Prohibition Detected	The operation was stopped according to the user setting because the motor ran in the prohibited direction when the Drive Prohibition was enabled.	<ul style="list-style-type: none"> Incorrect or broken wiring of Positive Drive Prohibition Input (POT) or Negative Drive Prohibition Input (NOT) Incorrect setting of the Drive Prohibition Input 	√			P. A-54
68210000	Control Right Release Error	Communications between the Sysmac Studio and Servo Drive were interrupted while a specific function was used from the Sysmac Studio.	<ul style="list-style-type: none"> The USB cable or EtherCAT cable was disconnected during the connection with the Sysmac Studio There is excessive noise A command sent from the Sysmac Studio was not sent to the Servo Drive because the computer was in a busy state or the like 	√			P. A-55
68220000	Error Stop Input	The Error Stop Input (ESTP) is active.	<ul style="list-style-type: none"> The Error Stop Input (ESTP) was input The Error Stop Input (ESTP) is incorrectly wired 	√			P. A-56
68230000	Software Limit Exceeded	The Position actual value detected the position that exceeded the value set in the Software Position Limit, and stopped the operation according to the user setting.	<ul style="list-style-type: none"> Incorrect setting of Software Position Limit When the Software Position Limit - Stop Selection was set to <i>Stop according to the setting of Fault reaction option code</i>, the position exceeded the value set in the Software Position Limit 	√			P. A-56
78200000	Pulse Output Over-speed Error	The speed, which exceeded the frequency that could be output by the Encoder Dividing Pulse Output function, was detected.	<ul style="list-style-type: none"> The dividing ratio setting is inappropriate for the actual usage condition 	√			P. A-57
78210000	Brake Interlock Error	The Brake Interlock Output (BKIR) was output by the Timeout at Servo OFF.	<ul style="list-style-type: none"> The Brake Interlock Output (BKIR) was output because the motor rotation speed did not decrease to or less than the speed set in the Threshold Speed at Servo OFF within the time set in the Timeout at Servo OFF when Servo OFF was performed during the motor operation 	√			P. A-57

Event code (hex)	Event name	Description	Assumed cause	Level			Reference
				Min	Obs	Info	
78230000	Command Error	A mistake was made in using a command.	<ul style="list-style-type: none"> When bit 9 (Remote) of the Statusword was set to 1 (remote), and the Servo Drive was in <i>Operation enabled</i> state (Servo ON), the Servo Drive received a command to change the communications state from Operational to another state (Init, Pre-Operational, or Safe-Operational) A mode of operation other than the hm mode was set during the homing operation Modes of operation was set to pp, pv or hm mode when the communications period was set to shorter than 250 μs 	√			P. A-58
84B10000	EtherCAT State Change Error	A communications state change command was received for which the current communications state could not be changed.	<ul style="list-style-type: none"> A communications state change command was received for which the current communications state could not be changed 	√			P. A-59
84B20000	EtherCAT Illegal State Change Error	An undefined communications state change command was received.	<ul style="list-style-type: none"> An undefined communications state change command was received 	√			P. A-59
84B40000	Synchronization Error	A signal for synchronous communications could not be detected.	<ul style="list-style-type: none"> Noise Error of the EtherCAT slave communications controller 	√			P. A-60
84B50000	Sync Manager WDT Error	PDO communications were interrupted for the allowable period or longer.	<ul style="list-style-type: none"> An EtherCAT communications cable is disconnected, loose, or broken Host controller error 	√			P. A-60
84B60000	ESC Initialization Error	The initialization of EtherCAT slave communications controller failed.	<ul style="list-style-type: none"> Data was incorrectly overwritten in the non-volatile memory of the EtherCAT slave communications controller Failure of the EtherCAT slave communications controller 	√			P. A-61
84B70000	SII Verification Error	An error occurred in SII data of the EtherCAT slave communications controller.	<ul style="list-style-type: none"> Data was incorrectly overwritten in the non-volatile memory of the EtherCAT slave communications controller Failure of the EtherCAT slave communications controller or false detection 	√			P. A-61

Event code (hex)	Event name	Description	Assumed cause	Level			Reference
				Min	Obs	Info	
84B90000	Synchronization Interruption Error	Synchronization interruption did not occur within the specified period.	<ul style="list-style-type: none"> Incorrect EtherCAT synchronization setting of the host controller Failure of the EtherCAT slave communications controller or false detection 	√			P. A-62
84BA0000	Bootstrap State Transition Request Error	The state transition to unsupported Bootstrap was requested.	<ul style="list-style-type: none"> The EtherCAT master requested the transition of unsupported Bootstrap 	√			P. A-62
88100000	Communications Synchronization Error	Communications were not established consecutively because the synchronization with the EtherCAT Master could not be achieved.	<ul style="list-style-type: none"> The power supply to the host controller was interrupted during PDO communications An EtherCAT communications cable is disconnected, loose, broken, or has a contact failure Noise 	√			P. A-63
88120000	Safety Communications Timeout	A communications timeout occurred in safety process data communications with the Safety CPU Unit.	<ul style="list-style-type: none"> A setting is not correct. The setting of the safety task period of the Safety CPU Unit is too short There is excessive noise The Safety CPU Unit or safety slave entered a status where it could not continue safety process data communications 	√			P. A-64
98200000	Absolute Value Cleared	The multi-rotation counter of the absolute encoder was cleared.	<ul style="list-style-type: none"> The multi-rotation counter of the absolute encoder was cleared 	√			P. A-64
081C0000	Capacitor Lifetime Warning	The capacitor built into the Servo Drive reached the service life.	<ul style="list-style-type: none"> The operating time of the capacitor in the Servo Drive exceeded the service life 		√		P. A-65
081D0000	Inrush Current Prevention Relay Lifetime Warning	The inrush current prevention relay built into the Servo Drive reached the service life.	<ul style="list-style-type: none"> The number of operating times of the inrush current prevention relay in the Servo Drive exceeded the service life 		√		P. A-65
081F0000	Brake Interlock Output Relay Lifetime Warning	The brake interlock output (BKIR) relay built into the Servo Drive reached the service life.	<ul style="list-style-type: none"> The number of operating times of the brake interlock output in the Servo Drive exceeded the service life 		√		P. A-66
083A0000	Encoder Communications Warning	Encoder communications errors occurred in series more frequently than the specified value.	<ul style="list-style-type: none"> Noise into the encoder cable Contact failure of the encoder cable Power supply undervoltage to the encoder 		√		P. A-67
08470000	Encoder Lifetime Warning	The encoder lifetime is close to the end.	<ul style="list-style-type: none"> Temporary noise The end of the encoder life 		√		P. A-68

Event code (hex)	Event name	Description	Assumed cause	Level			Reference
				Min	Obs	Info	
084C0000	Fan Rotation Warning	The rotation speed of the fan is 80% or less of the rating and the cooling performance decreases.	<ul style="list-style-type: none"> There is a foreign matter in the cooling fan and it blocks the rotation Cooling fan failure 		√		P. A-68
084E0000	Absolute Encoder Counter Overflow Warning	The multi-rotation counter of the encoder exceeded the value set in Encoder - Absolute Encoder Counter Overflow Warning Level (4510-02 hex).	<ul style="list-style-type: none"> An inappropriate value was set in the Encoder - Operation Selection when Using Absolute Encoder (4510-01 hex) The multi-rotation number of the encoder exceeded the warning level 		√		P. A-69
18390000	Lifetime Information Corruption Warning	An error was detected in the saved lifetime information.	<ul style="list-style-type: none"> The lifetime information corruption was detected when the power supply was turned ON 		√		P. A-70
34E00000	Data Setting Warning	The object set value is out of the range.	<ul style="list-style-type: none"> The object set value is out of the range 		√		P. A-70
387A0000	Overload Warning	The Load Ratio of Servo Drive or motor (4150-81 hex) exceeded the level set in Overload - Warning Notification Level (4150-01 hex).	<ul style="list-style-type: none"> Operation was continued for a long time with high load. There is incorrect wiring of the motor cable or a broken cable Increase in friction 		√		P. A-71
387D0000	Regeneration Overload Warning	The Regeneration Load Ratio (4150-81 hex) exceeded 85%.	<ul style="list-style-type: none"> The regeneration processing is set inappropriately The Regeneration Resistor is selected inappropriately The Regeneration Resistor is used for continuous regenerative braking The applied power supply voltage is higher than the specified value Regeneration Resistor failure 		√		P. A-72
387E0000	Motor Vibration Warning	The motor vibration, which was higher than or equal to the level set in the Vibration Detection - Detection Level (3B70-01 hex), was detected.	<ul style="list-style-type: none"> The control parameter is set inappropriately The rigidity decreased due to mechanical looseness or wear 		√		P. A-73

Event code (hex)	Event name	Description	Assumed cause	Level			Reference
				Min	Obs	Info	
78220000	Command Warning	A command could not be executed.	<ul style="list-style-type: none"> The <i>Switch ON</i> command was received The <i>Enable operation</i> command was received An operation command in the prohibition direction was received after the immediate stop by the Drive Prohibition Input or Software Position Limit Homing started The positioning start command was received in the Profile position mode 		√		P. A-74
84B00000	EtherCAT Communications Warning	An EtherCAT communications error occurred more than one time.	<ul style="list-style-type: none"> An EtherCAT communications cable has a contact failure, or is connected incorrectly or broken Noise 		√		P. A-75
90A00000	Unit Restarted	Restart was performed.	<ul style="list-style-type: none"> Restart was performed 			√	P. A-75
98210000	STO Detected	The safety input OFF state was detected via the safety input signal or EtherCAT communications.	<ul style="list-style-type: none"> The cable is disconnected or broken The STO input was turned OFF via EtherCAT communications 			√	P. A-76
98220000	Memory All Cleared	The Unit setting was cleared.	<ul style="list-style-type: none"> Clear All Memory was performed 			√	P. A-76
98240000	Event Log Cleared	The event log was cleared.	<ul style="list-style-type: none"> Clear Event Log was performed 			√	P. A-77

*1. This error can occur in the unit version 1.2 or later.

*2. This error can occur in the unit version 1.1 or later.

A-1-2 Error Descriptions

This section describes errors.

Error Table

The items that are used to describe individual errors (events) are described in the following copy of an error table.

Event name	Gives the name of the error (event).		Event code	Gives the code of the error (event).		
Description	Gives a short description of the error (event).					
Source	Gives the source of the error (event).		Source details	Gives details on the source of the error.	Detection timing	Tells when the error is detected.
Error attributes	Level	Tells the influence on control.*1	Recovery	Gives the recovery method.*2	Log category	Tells which log the error is saved in.
Effects	User program	Tells what will happen to execution of the user program.*3	Operation	Provides special information on the operation that results from the error (event).		
Indicators	EtherCAT NET RUN		EtherCAT NET ERR		EtherCAT LINK/ACT	
	Gives the status of the built-in EtherNet/IP port and built-in EtherCAT port indicators. Indicator status is given only for errors in the EtherCAT Master Function Module and the EtherNet/IP Function Module.					
System-defined variables	Variable		Data type		Name	
	Lists the variable names, data types, and meanings for system-defined variables that provide direct error notification, that are directly affected by the error, or that contain settings that cause the error.					
Cause and correction	Assumed cause		Correction		Prevention	
	Lists the possible causes, corrections, and preventive measures for the error (event).					
Attached information	Provides the additional information that is displayed by the Sysmac Studio or an NS-series PT.					
Precautions/Remarks	Provides precautions, restrictions, and supplemental information.					

*1. One of the following:

- Minor fault: Minor fault level
- Observation
- Information

*2. One of the following:

- Automatic recovery: Normal status is restored automatically when the cause of the error is removed.
- Error reset: Normal status is restored when the error is reset after necessary measures are taken.
- Cycle the power supply: Normal status is restored when the power supply is turned OFF and then back ON after necessary measures are taken.
- Replace the Servo Drive: Normal status is restored when the Servo Drive is replaced with a new one.

*3. "Continues." indicates that execution of the user program will continue.

Error Descriptions

Event name	Regeneration Circuit Error Detected during Power ON		Event code	04B30000 hex* ¹	
Meaning	An error of the Regeneration Circuit was detected at power ON.				
Source	EtherCAT Master Function Module		Source details	Slave	Detection timing
		Continuously			
Error attributes	Level	Minor fault	Recovery	Error reset (after cycling slave power)	Log category
					System log
Effects	User program	Continues.	Operation	Power drive circuit is OFF	
Indicators	EtherCAT NET RUN		EtherCAT NET ERR		EtherCAT LINK/ACT
	---		---		---
System -defined variables	Variable	Data type	Name		
	None	None	None		

	Assumed cause	Correction	Prevention
Cause and correction	<ul style="list-style-type: none"> Power supply voltage is insufficient at power ON, or rising slowly. Power supply voltage fluctuated at power ON. L1, L2, and L3 terminals are not connected or disconnected. N1 and N2 terminals are opened. 	<p>Cut off the main circuit power supply immediately and check whether charge lamp is turned ON/OFF.</p> <p>If the charge lamp is turned OFF, remove the wiring and make the following check.</p> <ul style="list-style-type: none"> Check whether there is an abnormality in the appearance of the Servo Drive, and that the wiring is properly done. Check that the resistance value and the power of the External Regeneration Resistor is correct. Wait until the voltage between P and N1 goes to less than 1 V to check the resistance value between P and N1. (If it is less than 10 kΩ, replace the Servo Drive.) Wait until the voltage get stable to check the resistance value between B2 and N1. (If it is less than 100 kΩ, replace the Servo Drive.) Check whether fluctuation in the power supply voltage or power supply occurs or not. (Make sure that an instantaneous power drop does not occur, and that the power rise time is 500 ms or shorter.) <p>If the charge lamp is turned ON, check whether fluctuation in the power supply voltage or power supply occurs or not. (Make sure that an instantaneous power drop does not occur, and that the power rise time is 500 ms or shorter.)</p>	<ul style="list-style-type: none"> If you are using the External Regeneration Resistor, make sure that an appropriate resistance value is set and that it is a resistor for the electric power. Increase the power supply capacity to improve the power environment. Separate the Servo Drive and cables from the noise source, or install other devices separately with the power line of the Servo Drive so that the surge voltage that is too large is not imposed. Power rise time must be 500 ms or shorter. Check that the wiring for the following terminals is properly done: L1, L2, L3, N1, N2, N3, B1, B2, B3, and P.
	Servo Drive failure	If this event occurs again after you performed all corrections shown above, replace the Servo Drive.	None
Attached information	Attached information 1: System information		
Precautions/Remarks	AL status code: -, Error No.: 1402 hex		

*1. This error can occur in the unit version 1.2 or later.

Event name	ESC Error		Event code	05430000 hex	
Meaning	An error occurred in the EtherCAT slave communications controller.				
Source	EtherCAT Master Function Module	Source details	Slave	Detection timing	At power ON
Error attributes	Level	Minor fault	Recovery	Error reset (after cycling slave power)	Log category System log
Effects	User program	Continues.	Operation	Power drive circuit is OFF	
Indicators	EtherCAT NET RUN		EtherCAT NET ERR		EtherCAT LINK/ACT
	---		---		---
System -defined variables	Variable	Data type	Name		
	None	None	None		
Cause and correction	Assumed cause	Correction	Prevention		
	Error of the EtherCAT slave communications controller or false detection when the AL status code is 0051 hex	If this event occurs repeatedly after you cycled the power supply, the EtherCAT slave communications controller is faulty. Replace the Servo Drive.	None		
	Error access from the non-OMRON EtherCAT master when the AL status code is 0050 hex	Please contact the manufacturer of EtherCAT master.			
Attached information	None				
Precautions/Remarks	AL status code: 0050 hex or 0051 hex, Error No.: 8804 hex				

Event name	Power Module Error		Event code	08390000 hex	
Description	An error was detected in the power module.				
Source	EtherCAT Master Function Module		Source details	Slave	Detection timing Continuously
Error attributes	Level	Minor fault	Recovery	Error reset (after cycling slave power)	Log category System log
Effects	User program	Continues.	Operation	Power drive circuit is OFF	
Indicators	EtherCAT NET RUN		EtherCAT NET ERR		EtherCAT LINK/ACT
	---		---		---
System-defined variables	Variable		Data type		Name
	None		None		None
Cause and correction	Assumed cause		Correction		Prevention
	There is a short-circuit, ground fault, or contact failure on the U, V, or W motor cable		Correct the connection of the U, V, or W motor cable.		Confirm that the motor cables are not broken and connect them correctly.
	There is a short-circuit on the wiring of External Regeneration Resistor or the resistance value is small		If there is a short-circuit on the wiring of External Regeneration Resistor, correct the wiring.		Wire the External Regeneration Resistor correctly when using it. Use the recommended External Regeneration Resistor. If a resistance value of the External Regeneration Resistor is small, excessive current will flow into the power module and cause a failure.
	The insulation resistance failed between the U, V, or W motor cable and the motor ground wire		Replace the motor.		Confirm that the insulation resistance is insulated between the U, V, and W motor cable and the motor ground wire before using the motor.
	Servo Drive failure		If this event occurs again after you performed all corrections shown above, replace the Servo Drive.		Do not perform Servo ON/OFF frequently. Doing so may cause a Servo Drive failure.
Attached information	Attached information 1: System information				
Precautions/Remarks	AL status code: -, Error No.: 1401 hex				

Event name	Self-diagnosis Error		Event code	083B0000 hex	
Description	An error was detected by the self-diagnosis of the safety function.				
Source	EtherCAT Master Function Module		Source details	Slave	Detection timing Continuously
Error attributes	Level	Minor fault	Recovery	Error reset (after cycling slave power)	Log category System log
Effects	User program	Continues.	Operation	Power drive circuit is OFF	
Indicators	EtherCAT NET RUN		EtherCAT NET ERR		EtherCAT LINK/ACT
	---		---		---
System -defined variables	Variable	Data type		Name	
	None	None		None	
Cause and correction	Assumed cause		Correction		Prevention
	False detection due to a data read error that was caused by excessive noise		If this event does not occur after you cycled the power supply, use the product continuously. It is supposed that a temporary error occurred due to a read error. If this event occurs again, replace the Servo Drive.		If the normal operation can restart after you cycled the power supply, consider noise countermeasures. There may be excessive noise around the Servo Drive.
	Hardware failure				
Attached information	Attached information 1: System information				
Precautions/Remarks	AL status code: -, Error No.: 3502 hex				

Event name	Main Circuit Temperature Monitoring Circuit Failure		Event code	083C0000 hex	
Description	A temperature monitoring circuit failure was detected on the main circuit.				
Source	EtherCAT Master Function Module		Source details	Slave	Detection timing Continuously
Error attributes	Level	Minor fault	Recovery	Error reset (after cycling slave power)	Log category System log
Effects	User program	Continues.	Operation	Power drive circuit is OFF	
Indicators	EtherCAT NET RUN		EtherCAT NET ERR		EtherCAT LINK/ACT
	---		---		---
System -defined variables	Variable	Data type		Name	
	None	None		None	
Cause and correction	Assumed cause		Correction		Prevention
	Broken wiring of the thermistor, temperature monitoring circuit failure		If this event occurs repeatedly after you cycled the power supply, replace the Servo Drive.		None
Attached information	None				
Precautions/Remarks	AL status code: -, Error No.: 5800 hex				

Event name	Fan Error		Event code	083D0000 hex	
Description	The rotation speed of the fan is 40% or less of the rating and the cooling performance decreases.				
Source	EtherCAT Master Function Module		Source details	Slave	Detection timing Continuously
Error attributes	Level	Minor fault	Recovery	Error reset (after resetting slave errors)	Log category System log
Effects	User program	Continues.	Operation	Power drive circuit is OFF	
Indicators	EtherCAT NET RUN		EtherCAT NET ERR		EtherCAT LINK/ACT
	---		---		---
System-defined variables	Variable		Data type		Name
	None		None		None
Cause and correction	Assumed cause		Correction		Prevention Do not use the fan in an area surrounded by excessive foreign matter. Also, do not allow foreign objects to enter.
	There is a foreign matter in the cooling fan and it blocks the rotation		Check whether there is a foreign matter in the fan. If you find a foreign matter, remove it.		
	Cooling fan failure		If there is no improvement after you performed the correction above, replace the Servo Drive.		
Attached information	None				
Precautions/Remarks	AL status code: -, Error No.: 5900 hex				

Event name	Regeneration Processing Error		Event code	083F0000 hex	
Description	The regeneration processing was stopped to protect the Regeneration Resistor.				
Source	EtherCAT Master Function Module	Source details	Slave	Detection timing	Continuously
Error attributes	Level	Minor fault	Recovery	Error reset (after cycling slave power)	Log category System log
Effects	User program	Continues.	Operation	Power drive circuit is OFF	
Indicators	EtherCAT NET RUN		EtherCAT NET ERR		EtherCAT LINK/ACT
	---		---		---
System-defined variables	Variable	Data type		Name	
	None	None		None	
Cause and correction	Assumed cause		Correction		Prevention
	The regeneration processing is set inappropriately		Check the regeneration processing setting, and set the same value as the resistance value of the Regeneration Resistor in use.		Check the items given for corrections in advance and take countermeasures as required.
	The Regeneration Resistor is selected inappropriately		Check the operation pattern by the velocity monitor. Check the load ratio of Regeneration Resistor, and perform the following corrections accordingly. <ul style="list-style-type: none"> • Increase the deceleration time and stopping time. • Decrease the command velocity to the motor. • Use an External Regeneration Resistor. • Increase the capacity of the Servo Drive and the motor. 		
	The Regeneration Resistor is used for continuous regenerative braking		The Regeneration Resistor cannot be used for continuous regenerative braking.		Do not use the Regeneration Resistor for continuous regenerative braking.
	The applied power supply voltage is higher than the specified value		Apply the specified power supply voltage.		Review the power supply voltage to be the specified value before use.
	Regeneration Resistor failure		Check whether the Regeneration Resistor is faulty, and use one without failures.		Confirm that the Regeneration Resistor is not faulty before use.
Attached information	None				
Precautions/Remarks	AL status code: -, Error No.: 1802 hex				

Event name	Overvoltage Error		Event code	0841 0000 hex	
Meaning	The main circuit power supply voltage (P-N voltage) exceeded the operation guarantee range.				
Source	EtherCAT Master Function Module		Source details	Slave	Detection timing Continuously
Error attributes	Level	Minor fault	Recovery	Error reset (after cycling slave power)	Log category System log
Effects	User program	Continues.	Operation	Power drive circuit is OFF	
Indicators	EtherCAT NET RUN		EtherCAT NET ERR		EtherCAT LINK/ACT
	---		---		---
System-defined variables	Variable		Data type		Name
	None		None		None
Cause and correction	Assumed cause		Correction		Prevention
	The P-N voltage exceeded the specified value		Input the correct voltage.		Input the correct voltage.
	The input voltage increased		Use appropriately external devices such as UPS.		Use appropriately external devices such as UPS.
	The Regeneration Resistor wiring is broken		If a resistance value of the external resistor is infinite between the terminal B1 and B2 of the Servo Drive, the wiring is broken. Replace the external resistor.		Check a resistance value of the external resistor.
	The External Regeneration Resistor is set or selected inappropriately		Confirm the necessary regeneration processing capacity, and connect an appropriate External Regeneration Resistor. Also, set the parameters of the External Regeneration Resistor to the resistance value of the External Regeneration Resistor in use.		Select an External Regeneration Resistor after calculating the necessary regeneration processing capacity because it varies with operation patterns or the like. Also, set the parameter correctly when using the External Regeneration Resistor.
	Servo Drive failure		If this event occurs again after you performed all corrections shown above, replace the Servo Drive.		None
Attached information	None				
Precautions/Remarks	AL status code: -, Error No.: 1200 hex				

Event name	Motor Overheat Error		Event code	08420000 hex	
Description	The encoder detected the temperature that exceeded the protection level of motor.				
Source	EtherCAT Master Function Module	Source details	Slave	Detection timing	Continuously
Error attributes	Level	Minor fault	Recovery	Error reset (after resetting slave errors)	Log category System log
Effects	User program	Continues.	Operation	Power drive circuit is OFF	
Indicators	EtherCAT NET RUN		EtherCAT NET ERR		EtherCAT LINK/ACT
	---		---		---
System -defined variables	Variable	Data type		Name	
	None	None		None	
Cause and correction	Assumed cause		Correction		Prevention
	The temperature is high around the motor		Adjust the temperature around the motor to be within the range of the operating temperature.		Adjust the ambient temperature to be within the range of the operating temperature before using the motor.
	The motor is overloaded		Adjust the motor load ratio to be within the specified range.		Adjust the operation before use, so that the motor load ratio does not become high for a long time.
	Encoder failure		Replace the motor if this event occurs repeatedly.		None
Attached information	None				
Precautions/Remarks	AL status code: -, Error No.: 1501 hex				

Event name	1-rotation Counter Error		Event code	08430000 hex	
Description	The encoder detected a one-rotation counter error.				
Source	EtherCAT Master Function Module	Source details	Slave	Detection timing	Continuously
Error attributes	Level	Minor fault	Recovery	Error reset (after cycling slave power)	Log category System log
Effects	User program	Continues.	Operation	Power drive circuit is OFF	
Indicators	EtherCAT NET RUN		EtherCAT NET ERR		EtherCAT LINK/ACT
	---		---		---
System -defined variables	Variable	Data type		Name	
	None	None		None	
Cause and correction	Assumed cause		Correction		Prevention
	There is excessive noise Failure due to vibration, impact, condensation, foreign matter, etc.		Take noise countermeasures. If this event occurs after you performed noise countermeasures, the motor is faulty. Replace the motor.		Take noise countermeasures. Do not use the product in an area surrounded by excessive foreign matter. Also, do not allow foreign matter to enter.
Attached information	Attached information 1: System information				
Precautions/Remarks	AL status code: -, Error No.: 4400 hex				

Event name	Overspeed Error		Event code	0844 0000 hex	
Meaning	The encoder detected the overspeed.				
Source	EtherCAT Master Function Module	Source details	Slave	Detection timing	Continuously
Error attributes	Level	Minor fault	Recovery	Error reset (after cycling slave power)	Log category System log
Effects	User program	Continues.	Operation	Power drive circuit is OFF	
Indicators	EtherCAT NET RUN		EtherCAT NET ERR		EtherCAT LINK/ACT
	---		---		---
System-defined variables	Variable	Data type		Name	
	None	None		None	
Cause and correction	Assumed cause		Correction		Prevention
	The motor is rotated by external forces		Take countermeasures so that the motor is not subjected to external forces if the motor is rotated by external forces.		Take countermeasures so that the motor is not rotated by external forces.
	Encoder failure and false detection		If this event occurs repeatedly, the encoder is faulty. Replace the motor.		None
Attached information	None				
Precautions/Remarks	AL status code: -, Error No.: 4700 hex				

Event name	Encoder Memory Error		Event code	0845 0000 hex	
Description	The encoder detected a non-volatile memory error.				
Source	EtherCAT Master Function Module	Source details	Slave	Detection timing	Continuously
Error attributes	Level	Minor fault	Recovery	Error reset (after cycling slave power)	Log category System log
Effects	User program	Continues.	Operation	Power drive circuit is OFF	
Indicators	EtherCAT NET RUN		EtherCAT NET ERR		EtherCAT LINK/ACT
	---		---		---
System-defined variables	Variable	Data type		Name	
	None	None		None	
Cause and correction	Assumed cause		Correction		Prevention
	False detection due to a data read error that was caused by excessive noise		If this event occurs after you cycled the power supply, the encoder is faulty. Replace the motor.		None
	Non-volatile memory failure				
Attached information	None				
Precautions/Remarks	AL status code: -, Error No.: 4301 hex				

Event name	Absolute Position Detection Error		Event code	08460000 hex	
Description	The encoder detected a multi-rotation counter error.				
Source	EtherCAT Master Function Module	Source details	Slave	Detection timing	Continuously
Error attributes	Level	Minor fault	Recovery	Error reset (after cycling slave power)	Log category System log
Effects	User program	Continues.	Operation	Power drive circuit is OFF	
Indicators	EtherCAT NET RUN		EtherCAT NET ERR		EtherCAT LINK/ACT
	---		---		---
System -defined variables	Variable	Data type		Name	
	None	None		None	
Cause and correction	Assumed cause		Correction		Prevention
	A detection error was detected in the multi-rotation detection section of the encoder		Perform the Absolute Encoder Setup after cycling the power supply, and update the multi-rotation number.		None
	There is excessive noise		Take noise countermeasures. Replace the motor if this event occurs repeatedly.		Take noise countermeasures.
Attached information	None				
Precautions/Remarks	AL status code: -, Error No.: 4501 hex				

Event name	Main Power Supply Undervoltage (insufficient voltage between P and N)		Event code	0848 0000 hex	
Meaning	The main circuit power supply voltage fell below the operation guarantee range during Servo ON.				
Source	EtherCAT Master Function Module		Source details	Slave	Detection timing During Servo ON
Error attributes	Level	Minor fault	Recovery	Error reset (after resetting slave errors)	Log category System log
Effects	User program	Continues.	Operation	Power drive circuit is OFF	
Indicators	EtherCAT NET RUN		EtherCAT NET ERR		EtherCAT LINK/ACT
	---		---		---
System-defined variables	Variable		Data type		Name
	None		None		None
Cause and correction	Assumed cause		Correction		Prevention
	Incorrect wiring of the main circuit power supply		If the power supply cables are not wired to the main circuit power supply terminals (L1 , L2 , L3), connect them.		Check the wiring of the main circuit power supply before use.
	The low power supply voltage is applied to the Servo Drive		Increase the power supply capacity if it is small. Measure the applied power supply voltage, and apply the voltage according to the specification.		Apply the voltage appropriate for the Servo Drive.
	The long time was set in Momentary Hold Time and the voltage was decreased momentarily		Remove the cause that momentarily decreased the voltage. Set a short time in the Momentary Hold Time so as not to detect this error due to a momentary decrease in voltage.		Set an appropriate value in the Momentary Hold Time.
	Servo Drive failure		If this event occurs again after you performed all corrections shown above, replace the Servo Drive.		None
Attached information	None				
Precautions/Remarks	AL status code: -, Error No.: 1300 hex				

Event name	Overcurrent Error		Event code	08490000 hex	
Meaning	The current flowing to the motor exceeded the protection level.				
Source	EtherCAT Master Function Module	Source details	Slave	Detection timing	During Servo ON
Error attributes	Level	Minor fault	Recovery	Error reset (after cycling slave power)	Log category System log
Effects	User program	Continues.	Operation	Power drive circuit is OFF	
Indicators	EtherCAT NET RUN		EtherCAT NET ERR		EtherCAT LINK/ACT
	---		---		---
System -defined variables	Variable	Data type	Name		
	None	None	None		
Cause and correction	Assumed cause		Correction		Prevention
	There is a short-circuit, ground fault, or contact failure on the U, V, or W motor cable		Correct the connection of the U, V, or W motor cable.		Confirm that the motor cables are not broken and connect them correctly.
	There is a short-circuit on the wiring of External Regeneration Resistor		Correct the wiring of External Regeneration Resistor.		Wire the External Regeneration Resistor correctly when using it.
	The insulation resistance failed between the U, V, or W motor cable and the motor ground wire		Replace the motor.		Confirm that the insulation resistance is insulated between the U, V, and W motor cable and the motor ground wire before connecting and using the motor.
	False detection due to the noise		Take noise countermeasures.		Take noise countermeasures because excessive noise may cause false detection.
	Servo Drive failure		If this event occurs again after you performed all corrections shown above, replace the Servo Drive.		Do not perform Servo ON/OFF frequently. Doing so may cause a Servo Drive failure.
Attached information	None				
Precautions/Remarks	AL status code: -, Error No.: 1400 hex				

Event name	Encoder Communications Disconnection Error		Event code	084A0000 hex		
Description	The communications disconnection was detected between the encoder and the Servo Drive.					
Source	EtherCAT Master Function Module		Source details	Slave	Detection timing	Continuously
Error attributes	Level	Minor fault	Recovery	Error reset (after cycling slave power)	Log category	System log
Effects	User program	Continues.	Operation	Power drive circuit is OFF		
Indicators	EtherCAT NET RUN		EtherCAT NET ERR		EtherCAT LINK/ACT	
	---		---		---	
System-defined variables	Variable		Data type		Name	
	None		None		None	
Cause and correction	Assumed cause		Correction		Prevention	
	Noise into the encoder cable		<ul style="list-style-type: none"> Separate the motor cable and the encoder cable if they are bundled together. Connect the shield to FG. Check that the motor ground wire is connected to FG. 		<ul style="list-style-type: none"> Separate the motor cable and the encoder cable if they are bundled together. Connect the shield to FG. Check that the motor ground wire is connected to FG. 	
	Contact failure of the signal line, and disconnection of the encoder		Replace the encoder cable if it is broken. Firmly connect the encoder connector to the Servo Drive.		Confirm that the encoder is not broken before use, and connect the encoder connector to the Servo Drive securely.	
	Power supply undervoltage to the encoder		Use the recommended encoder cable.		Use the recommended encoder cable.	
	Encoder failure		If this event occurs again after you performed all corrections shown above, replace the motor.		None	
Attached information	None					
Precautions/Remarks	AL status code: -, Error No.: 2100 hex					

Event name	Encoder Communications Error		Event code	084B0000 hex	
Description	Illegal data was received from the encoder the specified number of times.				
Source	EtherCAT Master Function Module	Source details	Slave	Detection timing	Continuously
Error attributes	Level	Minor fault	Recovery	Error reset (after cycling slave power)	Log category System log
Effects	User program	Continues.	Operation	Power drive circuit is OFF	
Indicators	EtherCAT NET RUN		EtherCAT NET ERR		EtherCAT LINK/ACT
	---		---		---
System -defined variables	Variable	Data type		Name	
	None	None		None	
Cause and correction	Assumed cause	Correction		Prevention	
	Noise into the encoder cable	<ul style="list-style-type: none"> Separate the motor cable and the encoder cable if they are bundled together. Connect the shield to FG. Check that the motor ground wire is connected to FG. 		<ul style="list-style-type: none"> Separate the motor cable and the encoder cable if they are bundled together. Connect the shield to FG. Confirm that the motor ground wire is connected to FG. 	
	Contact failure of the signal line, and disconnection of the encoder	Replace the encoder cable if it is broken. Firmly connect the encoder connector to the Servo Drive.		Confirm that the encoder is not broken before use, and connect the encoder connector to the Servo Drive securely.	
	Power supply undervoltage to the encoder	Use the recommended encoder cable.		Use the recommended encoder cable.	
Attached information	None				
Precautions/Remarks	AL status code: -, Error No.: 2101 hex				

Event name	Non-volatile Memory Hardware Error		Event code	084D0000 hex		
Description	An error occurred on the non-volatile memory.					
Source	EtherCAT Master Function Module		Source details	Slave	Detection timing	At power ON
Error attributes	Level	Minor fault	Recovery	Error reset	Log category	System log
Effects	User program	Continues.	Operation	Power drive circuit is OFF		
Indicators	EtherCAT NET RUN		EtherCAT NET ERR		EtherCAT LINK/ACT	
	---		---		---	
System-defined variables	Variable		Data type		Name	
	None		None		None	
Cause and correction	Assumed cause		Correction		Prevention	
	False detection due to a data read error that was caused by excessive noise		After you cycled the power supply, if this error occurs continuously although the error is reset, the non-volatile memory is faulty. Replace the Servo Drive.		None	
	Non-volatile memory failure					
Attached information	Attached information 1: System information					
Precautions/Remarks	AL status code: -, Error No.: 3700 hex					

Event name	Absolute Encoder Multi-rotation Counter Error		Event code	18230000 hex		
Meaning	The encoder detected a multi-rotation counter error.					
Source	EtherCAT Master Function Module		Source details	Slave	Detection timing	Continuously
Error attributes	Level	Minor fault	Recovery	Error reset (after cycling slave power)	Log category	System log
Effects	User program	Continues.	Operation	Power drive circuit is OFF		
Indicators	EtherCAT NET RUN		EtherCAT NET ERR		EtherCAT LINK/ACT	
	---		---		---	
System-defined variables	Variable		Data type		Name	
	None		None		None	
Cause and correction	Assumed cause		Correction		Prevention	
	A temporary error occurred in the encoder multi-rotation detection function due to vibration, impact, or condensation		Use the product continuously if this event does not occur after improving the operating environment. Replace the motor if this event occurs again.		Do not use the product in an environment where the temperature and vibration resistance exceed the specified level.	
	Encoder failure					
Attached information	None					
Precautions/Remarks	AL status code: -, Error No.: 4500 hex					

Event name	System Error		Event code	18380000 hex		
Description	A hardware error due to the self-diagnosis and a fatal software error were detected.					
Source	EtherCAT Master Function Module		Source details	Slave	Detection timing	Continuously
Error attributes	Level	Minor fault	Recovery	Error reset (after cycling slave power)	Log category	System log
Effects	User program	Continues.	Operation	Power drive circuit is OFF		
Indicators	EtherCAT NET RUN		EtherCAT NET ERR		EtherCAT LINK/ACT	
	---		---		---	
System-defined variables	Variable	Data type		Name		
	None	None		None		
Cause and correction	Assumed cause		Correction		Prevention	
	False detection due to a data read error that was caused by excessive noise		If this event does not occur after you cycled the power supply, use the product continuously. It is supposed that a temporary error occurred due to a read error.		If the normal operation can restart after you cycled the power supply, consider noise countermeasures. There may be excessive noise around the Servo Drive.	
	A fatal software error was detected					
	Hardware failure		If this event occurs again, a fatal error exists. Replace the Servo Drive.			
Attached information	Attached information 1: System information					
Precautions/Remarks	AL status code: -, Error No.: 3501 hex					

Event name	Non-volatile Memory Data Error		Event code	183A0000 hex		
Description	An error of data saved in the non-volatile memory was detected.					
Source	EtherCAT Master Function Module		Source details	Slave	Detection timing	At power ON
Error attributes	Level	Minor fault	Recovery	Error reset	Log category	System log
Effects	User program	Continues.	Operation	Power drive circuit is OFF		
Indicators	EtherCAT NET RUN		EtherCAT NET ERR		EtherCAT LINK/ACT	
	---		---		---	
System-defined variables	Variable	Data type		Name		
	None	None		None		
Cause and correction	Assumed cause		Correction		Prevention	
	Power interruption or noise occurred while parameters other than the safety were saved		Save data after setting the parameter again, and cycle the power supply.		Do not interrupt the power while the parameter is saved.	
	Power interruption or noise occurred while the motor identity information was saved		Execute the Motor Setup, and cycle the power supply.			
	Power interruption or noise occurred while safety parameters were saved		Clear the FSoE slave address, execute FSoE Enable Reset, and cycle the power supply.			
Attached information	Attached Information 1: Cause Details 1: Data corruption of parameters other than the safety 2: Data corruption of the motor identity information 3: Data corruption of the safety parameters					
Precautions/Remarks	AL status code: -, Error No.: 3600 hex					

Event name	Motor Non-conformity		Event code	246D0000 hex	
Description	The Servo Drive and motor combination is not correct.				
Source	EtherCAT Master Function Module		Source details	Slave	Detection timing
Error attributes	Level	Minor fault	Recovery	Error reset (after cycling slave power)	Log category
Effects	User program	Continues.	Operation	Power drive circuit is OFF	
Indicators	EtherCAT NET RUN		EtherCAT NET ERR		EtherCAT LINK/ACT
	---		---		---
System-defined variables	Variable	Data type		Name	
	None	None		None	
Cause and correction	Assumed cause		Correction		Prevention
	The Servo Drive and motor combination is not correct		Replace the motor with one that matches the Servo Drive.		Use a motor that matches the Servo Drive.
Attached information	Attached Information 1: Cause Details 1: Error at a time when the capacity of the connected Servomotor does not conform to the capacity of Servo Drive. 2: The Servomotor with different operating voltage is connected.				
Precautions/Remarks	AL status code: -, Error No.: 9501 hex				

Event name	Main Circuit Power Supply Phase Loss Error		Event code	28080000 hex	
Description	The phase loss of the main circuit power supply was detected.				
Source	EtherCAT Master Function Module		Source details	Slave	Detection timing
Error attributes	Level	Minor fault	Recovery	Error reset (after resetting slave errors)	Log category
Effects	User program	Continues.	Operation	Power drive circuit is OFF	
Indicators	EtherCAT NET RUN		EtherCAT NET ERR		EtherCAT LINK/ACT
	---		---		---
System-defined variables	Variable	Data type		Name	
	None	None		None	
Cause and correction	Assumed cause	Correction		Prevention	
	Incorrect wiring, for example the single-phase power supply is input to a 3-phase input type Servo Drive	Confirm the Servo Drive specifications, and perform the correct wiring.		Confirm the Servo Drive specifications, and perform the correct wiring.	
	In the case where the single-phase power supply is input to a single- and 3-phase input type Servo Drive, the phase loss detection is enabled.	Set Main Circuit Power Supply - Phase Loss Detection Enable (4320-02 hex) to 0 (disabled).		Disable the phase loss detection when you input the single-phase power supply to a single- and 3-phase input type Servo Drive.	
	The power supply voltage is low or insufficient	Improve power supply conditions by increasing the power supply capacity or the like.		Improve power supply conditions by increasing the power supply capacity or the like.	
	Broken wiring of the main circuit power supply input	Replace the main circuit power supply input cable.		Confirm that the main circuit power supply input cable is not broken before use.	
	Servo Drive failure	If this event occurs again after you performed all corrections shown above, replace the Servo Drive.		None	
Attached information	None				
Precautions/Remarks	AL status code: -, Error No.: 1301 hex				

Event name	Runaway Detected		Event code	280D0000 hex ^{*1}	
Description	The motor rotated in the direction opposite to the command.				
Source	EtherCAT Master Function Module	Source details	Slave	Detection timing	Continuously
Error attributes	Level	Minor fault	Recovery	Error reset (after resetting slave errors)	Log category System log
Effects	User program	Continues.	Operation	Power drive circuit is OFF	
Indicators	EtherCAT NET RUN		EtherCAT NET ERR		EtherCAT LINK/ACT
	---		---		---
System -defined variables	Variable		Data type		Name
	None		None		None
Cause and correction	Assumed cause		Correction		Prevention
	There is incorrect wiring of the motor cable or a broken cable.		Connect the motor cable as shown in the wiring diagram. If the cable is broken, replace it. Or, connect the motor cable and encoder cable that are used together to the same motor.		Connect the motor cable as shown in the wiring diagram. Connect the motor cable and encoder cable/external encoder cable that are used together to the same motor.
The motor rotated in the direction opposite to the command by external forces.		Take countermeasures so that the motor is not subjected to external forces. Set Runaway Detection - Enable (3B71-01 hex) to 0 (disabled) when the motor runs as intended.		Take countermeasures so that the motor is not rotated by external forces.	
Attached information	None				
Precautions/ Remarks	AL status code: -, Error No.: 2000 hex				

*1. This error can occur in the unit version 1.1 or later.

Event name	DC Setting Error		Event code	357D0000 hex	
Description	A mistake was made in the DC Mode operation setting.				
Source	EtherCAT Master Function Module		Source details	Slave	Detection timing When establishing EtherCAT communications
Error attributes	Level	Minor fault	Recovery	Error reset	Log category System log
Effects	User program	Continues.	Operation	Power drive circuit is OFF	
Indicators	EtherCAT NET RUN		EtherCAT NET ERR		EtherCAT LINK/ACT
	---		---		---
System -defined variables	Variable	Data type		Name	
	None	None		None	
Cause and correction	Assumed cause		Correction		Prevention
	A mistake was made in the DC Mode operation setting		Check the DC Mode setting, and then download it to the EtherCAT master again.		Configure the setting of communications to slaves in the EtherCAT master in accordance with ESI data.
Attached information	None				
Precautions/Remarks	AL status code: 0030 hex, Error No.: 9003 hex				

Event name	Synchronization Cycle Setting Error		Event code	357E0000 hex	
Description	When the DC mode was established, the cycle time was set to the inoperable value.				
Source	EtherCAT Master Function Module		Source details	Slave	Detection timing When establishing EtherCAT communications
Error attributes	Level	Minor fault	Recovery	Error reset	Log category System log
Effects	User program	Continues.	Operation	Power drive circuit is OFF	
Indicators	EtherCAT NET RUN		EtherCAT NET ERR		EtherCAT LINK/ACT
	---		---		---
System -defined variables	Variable	Data type		Name	
	None	None		None	
Cause and correction	Assumed cause		Correction		Prevention
	The variable PDO mapping is used, and the number of objects is more than the maximum number of mapped objects for the cycle time		Set the number of objects to a value smaller than the maximum number of mapped objects for the cycle time.		Confirm the maximum number of mapped objects and the limit on the number of objects before using the variable PDO mapping.
	The cycle time setting is incorrect		Correct the cycle time setting.		Confirm the EtherCAT slave specifications, and set the cycle time.
Attached information	None				
Precautions/Remarks	AL status code: 0035 hex, Error No.: 9004 hex				

Event name	Mailbox Setting Error		Event code	357F 0000 hex	
Description	An incorrect mailbox setting of Sync Manager was detected.				
Source	EtherCAT Master Function Module		Source details	Slave	Detection timing When establishing EtherCAT communications
Error attributes	Level	Minor fault	Recovery	Error reset	Log category System log
Effects	User program	Continues.	Operation	Power drive circuit is OFF	
Indicators	EtherCAT NET RUN		EtherCAT NET ERR		EtherCAT LINK/ACT
	---		---		---
System-defined variables	Variable		Data type		Name
	None		None		None
Cause and correction	Assumed cause		Correction		Prevention
	An incorrect mailbox setting of Sync Manager was detected		Check the mailbox setting, and then download it to the EtherCAT master again.		Configure the setting of communications to slaves in the EtherCAT master in accordance with ESI data.
Attached information	None				
Precautions/Remarks	AL status code: 0016 hex, Error No.: 9000 hex				

Event name	RxPDO Setting Error		Event code	3580 0000 hex	
Meaning	An RxPDO setting error was detected.				
Source	EtherCAT Master Function Module		Source details	Slave	Detection timing When establishing EtherCAT communications
Error attributes	Level	Minor fault	Recovery	Error reset	Log category System log
Effects	User program	Continues.	Operation	Power drive circuit is OFF	
Indicators	EtherCAT NET RUN		EtherCAT NET ERR		EtherCAT LINK/ACT
	---		---		---
System-defined variables	Variable		Data type		Name
	None		None		None
Cause and correction	Assumed cause		Correction		Prevention
	The RxPDO setting of EtherCAT master is incorrect		Correct the RxPDO setting according to the definition of ESI of Servo Drive, and then download it to the EtherCAT master again.		Configure the setting of communications to slaves in the EtherCAT master in accordance with ESI data.
	Servo Drive failure		If this event occurs repeatedly after the download to the EtherCAT master, the Servo Drive is faulty. Replace the Servo Drive.		None
Attached information	None				
Precautions/Remarks	AL status code: 001D hex, Error No.: 9005 hex				

Event name	TxPDO Setting Error		Event code	35810000 hex		
Meaning	A TxPDO setting error was detected.					
Source	EtherCAT Master Function Module		Source details	Slave	Detection timing	When establishing EtherCAT communications
Error attributes	Level	Minor fault	Recovery	Error reset	Log category	System log
Effects	User program	Continues.	Operation	Power drive circuit is OFF		
Indicators	EtherCAT NET RUN		EtherCAT NET ERR		EtherCAT LINK/ACT	
	---		---		---	
System -defined variables	Variable	Data type		Name		
	None	None		None		
Cause and correction	Assumed cause		Correction		Prevention	
	The TxPDO setting of EtherCAT master is incorrect		Correct the TxPDO setting according to the definition of ESI of Servo Drive, and then download it to the EtherCAT master again.		Configure the setting of communications to slaves in the EtherCAT master in accordance with ESI data.	
	Servo Drive failure		If this event occurs repeatedly after the download to the EtherCAT master, the Servo Drive is faulty. Replace the Servo Drive.		None	
Attached information	None					
Precautions/Remarks	AL status code: 001E hex, Error No.: 9006 hex					

Event name	RxPDO Mapping Error		Event code	35820000 hex		
Meaning	An incorrect RxPDO was set.					
Source	EtherCAT Master Function Module		Source details	Slave	Detection timing	When establishing EtherCAT communications
Error attributes	Level	Minor fault	Recovery	Error reset	Log category	System log
Effects	User program	Continues.	Operation	Power drive circuit is OFF		
Indicators	EtherCAT NET RUN		EtherCAT NET ERR		EtherCAT LINK/ACT	
	---		---		---	
System -defined variables	Variable	Data type		Name		
	None	None		None		
Cause and correction	Assumed cause		Correction		Prevention	
	An incorrect RxPDO was set, such as out of the allowable range of Index, Subindex, or size		Correct the RxPDO setting, and then download it to the EtherCAT master again.		Confirm the specifications of ETG or FSoE, and configure the setting of communications to slaves in the EtherCAT master in accordance with ESI data.	
Attached information	None					
Precautions/Remarks	AL status code: 0025 hex, Error No.: 9007 hex					

Event name	TxPDO Mapping Error		Event code	3583 0000 hex	
Meaning	An incorrect TxPDO was set.				
Source	EtherCAT Master Function Module	Source details	Slave	Detection timing	When establishing EtherCAT communications
Error attributes	Level	Minor fault	Recovery	Error reset	Log category
Effects	User program	Continues.	Operation	Power drive circuit is OFF	
Indicators	EtherCAT NET RUN		EtherCAT NET ERR		EtherCAT LINK/ACT
	---		---		---
System-defined variables	Variable	Data type		Name	
	None	None		None	
Cause and correction	Assumed cause		Correction		Prevention
	An incorrect TxPDO was set, such as out of the allowable range of Index, Subindex, or size		Correct the TxPDO setting, and then download it to the EtherCAT master again.		Confirm the specifications of ETG or FSoE, and configure the setting of communications to slaves in the EtherCAT master in accordance with ESI data.
Attached information	None				
Precautions/Remarks	AL status code: 0024 hex, Error No.: 9008 hex				

Event name	PDO WDT Setting Error		Event code	3584 0000 hex	
Meaning	An incorrect PDO WDT setting was detected.				
Source	EtherCAT Master Function Module	Source details	Slave	Detection timing	When establishing EtherCAT communications
Error attributes	Level	Minor fault	Recovery	Error reset	Log category
Effects	User program	Continues.	Operation	Power drive circuit is OFF	
Indicators	EtherCAT NET RUN		EtherCAT NET ERR		EtherCAT LINK/ACT
	---		---		---
System-defined variables	Variable	Data type		Name	
	None	None		None	
Cause and correction	Assumed cause		Correction		Prevention
	An incorrect PDO WDT setting was detected		Check the PDO WDT setting, and then download it to the EtherCAT master again.		Configure the setting of communications to slaves in the EtherCAT master in accordance with ESI data.
Attached information	None				
Precautions/Remarks	AL status code: 001F hex, Error No.: 9001 hex				

Event name	Node Address Updated		Event code	35850000 hex		
Description	The node address is changed to a value of the ID switches.					
Source	EtherCAT Master Function Module		Source details	Slave	Detection timing	When establishing EtherCAT communications
Error attributes	Level	Minor fault	Recovery	Error reset (after cycling slave power)	Log category	System log
Effects	User program	Continues.	Operation	Not affected.		
Indicators	EtherCAT NET RUN		EtherCAT NET ERR		EtherCAT LINK/ACT	
	---		---		---	
System -defined variables	Variable		Data type		Name	
	None		None		None	
Cause and correction	Assumed cause		Correction		Prevention	
	The node address is changed from a set value in Sysmac Studio to a value of the ID switches		Check the node address value. Set a correct value if it is wrong.		---	
Attached information	None					
Precautions/Remarks	AL status code: 0061 hex, Error No.: 9009 hex					

Event name	SM Event Mode Setting Error		Event code	35860000 hex		
Meaning	The unsupported SM Event Mode was set.					
Source	EtherCAT Master Function Module		Source details	Slave	Detection timing	When establishing EtherCAT communications
Error attributes	Level	Minor fault	Recovery	Error reset	Log category	System log
Effects	User program	Continues.	Operation	Power drive circuit is OFF		
Indicators	EtherCAT NET RUN		EtherCAT NET ERR		EtherCAT LINK/ACT	
	---		---		---	
System -defined variables	Variable		Data type		Name	
	None		None		None	
Cause and correction	Assumed cause		Correction		Prevention	
	The unsupported SM Event Mode was set		Check the synchronization setting, and then download it to the EtherCAT master again.		Configure the setting of communications to slaves in the EtherCAT master in accordance with ESI data.	
Attached information	None					
Precautions/Remarks	AL status code: 0028 hex, Error No.: 9002 hex					

Event name	Function Setting Error		Event code	38570000 hex	
Meaning	The function that was set does not support the communications period.				
Source	EtherCAT Master Function Module		Source details	Slave	Detection timing When establishing EtherCAT communications
Error attributes	Level	Minor fault	Recovery	Error reset (after resetting slave errors)	Log category System log
Effects	User program	Continues.	Operation	Power drive circuit is OFF	
Indicators	EtherCAT NET RUN		EtherCAT NET ERR		EtherCAT LINK/ACT
	ON		---		---
System-defined variables	Variable	Data type		Name	
	None	None		None	
Cause and correction	Assumed cause		Correction		Prevention Check the Servo Drive specifications to avoid the amused causes of this event, and use the Servo Drive correctly.
	The electronic gear ratio was not 1:1 when the communications period was set to 125 μs.		Correct the electronic gear ratio to 1:1, or set the communications period to longer than 125 μs.		
	The Backlash Compensation was enabled when the communications period was set to 125 μs.		Disable the Backlash Compensation, or set the communications period to longer than 125 μs.		
Attached information	Attached information 1: Condition that was met 1: The electronic gear ratio was not 1:1 2: The Backlash Compensation was enabled				
Precautions/Remarks	AL status code: - Error No.: 9400 hex				

Event name	General Input Allocation Duplicate Error		Event code	38780000 hex		
Description	More than one function input is allocated to one general input.					
Source	EtherCAT Master Function Module		Source details	Slave	Detection timing	At power ON
Error attributes	Level	Minor fault	Recovery	Error reset (after cycling slave power)	Log category	System log
Effects	User program	Continues.	Operation	Power drive circuit is OFF		
Indicators	EtherCAT NET RUN		EtherCAT NET ERR		EtherCAT LINK/ACT	
	---		---		---	
System -defined variables	Variable		Data type		Name	
	None		None		None	
Cause and correction	Assumed cause		Correction		Prevention	
	More than one function input is allocated to one general input		Correct the duplicate general input allocation.		Confirm that there is no duplicate allocation when setting a function input.	
Attached information	Attached Information 1: Cause Details 1: General Input 1 (IN1) Allocation Duplicate Error 2: General Input 2 (IN2) Allocation Duplicate Error 3: General Input 3 (IN3) Allocation Duplicate Error 4: General Input 4 (IN4) Allocation Duplicate Error 5: General Input 5 (IN5) Allocation Duplicate Error 6: General Input 6 (IN6) Allocation Duplicate Error 7: General Input 7 (IN7) Allocation Duplicate Error 8: General Input 8 (IN8) Allocation Duplicate Error					
Precautions/Remarks	AL status code: -, Error No.: 3300 hex					

Event name	General Output Allocation Duplicate Error		Event code	38790000 hex		
Description	More than one function output is allocated to one general output.					
Source	EtherCAT Master Function Module		Source details	Slave	Detection timing	At power ON
Error attributes	Level	Minor fault	Recovery	Error reset (after cycling slave power)	Log category	System log
Effects	User program	Continues.	Operation	Power drive circuit is OFF		
Indicators	EtherCAT NET RUN		EtherCAT NET ERR		EtherCAT LINK/ACT	
	---		---		---	
System -defined variables	Variable		Data type		Name	
	None		None		None	
Cause and correction	Assumed cause		Correction		Prevention	
	More than one function output is allocated to one general output		Correct the duplicate general output allocation.		Confirm that there is no duplicate allocation when setting a function output.	
Attached information	Attached information 1: Cause details 1: General Output 1 (OUT1) Allocation Duplicate Error 2: General Output 2 (OUT2) Allocation Duplicate Error 3: General Output 3 (OUT3) Allocation Duplicate Error 4: General Output 4 (OUT4) Allocation Duplicate Error					
Precautions/Remarks	AL status code: -, Error No.: 3309 hex					

Event name	Pulse Output Setting Error		Event code	387B0000 hex	
Description	The dividing numerator exceeded the dividing denominator when the Encoder Dividing Pulse Output - Dividing Denominator was set to a value other than 0.				
Source	EtherCAT Master Function Module	Source details	Slave	Detection timing	At power ON
Error attributes	Level	Minor fault	Recovery	Error reset (after cycling slave power)	Log category System log
Effects	User program	Continues.	Operation	Power drive circuit is OFF	
Indicators	EtherCAT NET RUN		EtherCAT NET ERR		EtherCAT LINK/ACT
	---		---		---
System-defined variables	Variable	Data type		Name	
	None	None		None	
Cause and correction	Assumed cause		Correction		Prevention
	The dividing numerator exceeded the dividing denominator when the Encoder Dividing Pulse Output - Dividing Denominator was set to a value other than 0		Correct the setting of Encoder Dividing Pulse Output - Dividing Denominator and Dividing Numerator.		Set the Encoder Dividing Pulse Output - Dividing Numerator to a value smaller than the Dividing Denominator.
Attached information	None				
Precautions/Remarks	AL status code: -, Error No.: 2800 hex				

Event name	Motor Replacement Detected		Event code	387C0000 hex	
Description	The connected motor is different from the motor that was connected the last time.				
Source	EtherCAT Master Function Module	Source details	Slave	Detection timing	At power ON
Error attributes	Level	Minor fault	Recovery	Error reset (after cycling slave power)	Log category System log
Effects	User program	Continues.	Operation	Power drive circuit is OFF	
Indicators	EtherCAT NET RUN		EtherCAT NET ERR		EtherCAT LINK/ACT
	---		---		---
System-defined variables	Variable	Data type		Name	
	None	None		None	
Cause and correction	Assumed cause		Correction		Prevention
	The motor was replaced		Perform the Motor Setup and Absolute Encoder Setup.		After replacing the motor, perform the Motor Setup and Absolute Encoder Setup before use.
	The Servo Drive was replaced		Perform the Motor Setup.		After replacing the Servo Drive, perform the Motor Setup before use.
Attached information	None				
Precautions/Remarks	AL status code: -, Error No.: 9505 hex				

Event name	Electronic Gear Setting Error		Event code	387F 0000 hex		
Description	The electronic gear ratio exceeded the allowable range.					
Source	EtherCAT Master Function Module		Source details	Slave	Detection timing	At power ON
Error attributes	Level	Minor fault	Recovery	Error reset (after cycling slave power)	Log category	System log
Effects	User program	Continues.	Operation	Power drive circuit is OFF		
Indicators	EtherCAT NET RUN		EtherCAT NET ERR		EtherCAT LINK/ACT	
	---		---		---	
System -defined variables	Variable		Data type		Name	
	None		None		None	
Cause and correction	Assumed cause		Correction		Prevention	
	The electronic gear ratio exceeded the allowable range		Correct the electronic gear ratio to the range from 1/2,000 to 2,000 times.		Set the electronic gear ratio to the range from 1/2,000 to 2,000 times.	
Attached information	None					
Precautions/Remarks	AL status code: -, Error No.: 9300 hex					

Event name	Servo Drive Overheat		Event code	3880 0000 hex		
Meaning	The internal temperature of Servo Drive exceeded the circuit protection level.					
Source	EtherCAT Master Function Module		Source details	Slave	Detection timing	Continuously
Error attributes	Level	Minor fault	Recovery	Error reset (after resetting slave errors)	Log category	System log
Effects	User program	Continues.	Operation	Power drive circuit is OFF		
Indicators	EtherCAT NET RUN		EtherCAT NET ERR		EtherCAT LINK/ACT	
	---		---		---	
System -defined variables	Variable		Data type		Name	
	None		None		None	
Cause and correction	Assumed cause		Correction		Prevention	
	The ambient temperature of the Servo Drive exceeded the specified value		Improve the ambient temperature and the cooling conditions of the Servo Drive.		Check the ambient temperature of the Servo Drive and set up the necessary cooling conditions.	
	Overload		Increase the setting of the acceleration/deceleration time or stopping time to lighten the load. Or, increase the capacities of the Servo Drive and the motor.		Increase the setting of the acceleration/deceleration time or stopping time as much as possible to lighten the load.	
Attached information	None					
Precautions/Remarks	AL status code: -, Error No.: 1500 hex					

Event name	Overload Error		Event code	3881 0000 hex	
Meaning	The Load Ratio of Servo Drive or motor (4105-81 hex) exceeded 100%.				
Source	EtherCAT Master Function Module		Source details	Slave	Detection timing During Servo ON
Error attributes	Level	Minor fault	Recovery	Error reset (after resetting slave errors)	Log category System log
Effects	User program	Continues.	Operation	Power drive circuit is OFF	
Indicators	EtherCAT NET RUN		EtherCAT NET ERR		EtherCAT LINK/ACT
	---		---		---
System-defined variables	Variable		Data type		Name
	None		None		None
Cause and correction	Assumed cause		Correction		Prevention
	Operation was continued for a long time with high load		Perform the following corrections accordingly. <ul style="list-style-type: none"> • Increase the set value of the acceleration/deceleration time and the stop time. • Lighten the load. • Adjust the gain or inertia ratio. • If torque waveforms oscillate excessively, adjust the system by the tuning so that the oscillation does not occur. • Set the appropriate brake timing. • Increase the capacities of the Servo Drive and the motor. 		Check the items given for corrections in advance and take countermeasures as required.
	There is incorrect wiring of the motor cable or a broken cable		<ul style="list-style-type: none"> • Connect the motor cable as shown in the wiring diagram. If the cable is broken, replace it. Or, connect the motor cable and encoder cable that are used together to the same motor. • Measure the voltage at the brake terminal. If the brake is applied, release it. 		Connect the motor cable as shown in the wiring diagram. Connect the motor cable and encoder cable/external encoder cable that are used together to the same motor.
	Increase in friction		Check machine conditions and remove the cause of the friction.		Take countermeasures so that machine distortion is not generated.
Attached information	Attached Information 1: Cause Details 1: The Servo Drive is overloaded 2: The Servomotor is overloaded				
Precautions/Remarks	AL status code: -, Error No.: 1600 hex				

Event name	Regeneration Overload Error		Event code	38820000 hex	
Meaning	The Regeneration Load Ratio (4310-81 hex) exceeded the regeneration overload ratio.				
Source	EtherCAT Master Function Module	Source details	Slave	Detection timing	During Servo ON
Error attributes	Level	Minor fault	Recovery	Error reset (after cycling slave power)	Log category System log
Effects	User program	Continues.	Operation	Power drive circuit is OFF	
Indicators	EtherCAT NET RUN		EtherCAT NET ERR		EtherCAT LINK/ACT
	---		---		---
System-defined variables	Variable	Data type		Name	
	None	None		None	
Cause and correction	Assumed cause	Correction		Prevention	
	The regeneration processing is set inappropriately	Check the regeneration processing setting, and set the same value as the resistance value of the Regeneration Resistor in use.		Check the items given for corrections in advance and take countermeasures as required.	
	The Regeneration Resistor is selected inappropriately	Check the operation pattern by the velocity monitor. Check the load ratio of Regeneration Resistor, and perform the following corrections accordingly. <ul style="list-style-type: none"> • Increase the deceleration time and stopping time. • Decrease the command velocity to the motor. • Use an External Regeneration Resistor. • Increase the capacities of the Servo Drive and the motor. 			
	The Regeneration Resistor is used for continuous regenerative braking	The Regeneration Resistor cannot be used for continuous regenerative braking.		Do not use the Regeneration Resistor for continuous regenerative braking.	
	The applied power supply voltage is higher than the specified value	Apply the specified power supply voltage.		Review the power supply voltage to be the specified value before use.	
	Regeneration Resistor failure	Check whether the Regeneration Resistor is faulty, and use one without failures.		Confirm that the Regeneration Resistor is not faulty before use.	
Attached information	None				
Precautions/Remarks	AL status code: -, Error No.: 1800 hex				

Event name	Excessive Position Deviation Error		Event code	3883 0000 hex	
Meaning	The position deviation is greater than or equal to the value set in the Following error window.				
Source	EtherCAT Master Function Module		Source details	Slave	Detection timing During Servo ON
Error attributes	Level	Minor fault	Recovery	Error reset (after resetting slave errors)	Log category System log
Effects	User program	Continues.	Operation	Power drive circuit is OFF	
Indicators	EtherCAT NET RUN		EtherCAT NET ERR		EtherCAT LINK/ACT
	---		---		---
System-defined variables	Variable		Data type		Name
	None		None		None
Cause and correction	Assumed cause		Correction		Prevention
	The motor operation does not follow the command		Identify and remove a cause that limits the motor operation. During the acceleration/deceleration, the command may not be followed depending on operation patterns. In that case, adjust the gain, increase the acceleration/deceleration time or the like.		Adjust the gain and limit values appropriately before use. Set the operation pattern appropriately according to the connected load.
	The value of Following error window is small		Increase the setting of the Following error window to an acceptable range.		Increase the setting of the Following error window to an acceptable range.
Attached information	None				
Precautions/Remarks	AL status code: -, Error No.: 2400 hex				

Event name	Excessive Speed Deviation Error		Event code	3884 0000 hex	
Meaning	The speed deviation is greater than or equal to the value set in the Excessive Velocity Deviation Detection Level.				
Source	EtherCAT Master Function Module	Source details	Slave	Detection timing	During Servo ON
Error attributes	Level	Minor fault	Recovery	Error reset (after resetting slave errors)	Log category System log
Effects	User program	Continues.	Operation	Power drive circuit is OFF	
Indicators	EtherCAT NET RUN		EtherCAT NET ERR		EtherCAT LINK/ACT
	---		---		---
System -defined variables	Variable	Data type		Name	
	None	None		None	
Cause and correction	Assumed cause		Correction		Prevention
	The motor operation does not follow the command because a parameter value is inappropriate		Adjust the gain to improve the following ability. Or, increase the acceleration/deceleration time for the internal position command velocity.		Adjust the gain to improve the following ability. Or, increase the acceleration/deceleration time for the internal position command velocity.
	The output axis of motor is limited on the operation by external forces		Take countermeasures so that the output axis is not limited on the operation by external forces.		Take countermeasures so that the output axis is not limited on the operation by external forces.
	The value of the Excessive Velocity Deviation Detection Level is inappropriate		Increase the setting of the Excessive Velocity Deviation Detection Level to an acceptable range. Disable the Excessive Velocity Deviation Detection if it is unnecessary to monitor the velocity deviation.		Increase the setting of the Excessive Velocity Deviation Detection Level to an acceptable range. Disable the Excessive Velocity Deviation Detection if it is unnecessary to monitor the velocity deviation.
Attached information	None				
Precautions/Remarks	AL status code: -, Error No.: 2401 hex				

Event name	Excessive Speed Error		Event code	38850000 hex	
Meaning	The feedback motor speed is greater than or equal to the value set in the Excessive Speed Detection Level.				
Source	EtherCAT Master Function Module		Source details	Slave	Detection timing
Error attributes	Level	Minor fault	Recovery	Error reset (after resetting slave errors)	Log category
Effects	User program	Continues.	Operation	Power drive circuit is OFF	
Indicators	EtherCAT NET RUN		EtherCAT NET ERR		EtherCAT LINK/ACT
	---		---		---
System-defined variables	Variable		Data type		Name
	None		None		None
Cause and correction	Assumed cause		Correction		Prevention
	The velocity command value is too large		Do not give the excessive velocity command. Check whether the electronic gear ratio is set correctly.		Set the velocity command value within the range in which the feedback motor velocity does not exceed the excess velocity detection level.
	Overshooting occurred		If overshooting occurred due to faulty gain adjustment, adjust the gain.		Do not increase the gain too much.
	The motor is rotated by external forces		Check whether the motor is rotated by external forces.		Check whether the motor is rotated by external forces.
Attached information	None				
Precautions/Remarks	AL status code: -, Error No.: 2600 hex				

Event name	Following Error Counter Overflow		Event code	38860000 hex	
Meaning	The following error value exceeded the range from -2147483648 to 2147483647.				
Source	EtherCAT Master Function Module	Source details	Slave	Detection timing	During Servo ON
Error attributes	Level	Minor fault	Recovery	Error reset (after resetting slave errors)	Log category System log
Effects	User program	Continues.	Operation	Power drive circuit is OFF	
Indicators	EtherCAT NET RUN		EtherCAT NET ERR		EtherCAT LINK/ACT
	---		---		---
System -defined variables	Variable	Data type		Name	
	None	None		None	
Cause and correction	Assumed cause		Correction		Prevention
	The motor operation does not follow the command		Identify and remove a cause that limits the motor operation. During the acceleration/deceleration, the command may not be followed depending on operation patterns. In that case, change the operation pattern by increasing the acceleration/deceleration time or the like.		Adjust the gain and limit values appropriately before use. Set the operation pattern appropriately according to the connected load.
	The Servomotor is rotated or limited on the operation by external forces		Take countermeasures so that the motor is not subjected to external forces.		Take countermeasures so that the motor operation is not interfered by external forces.
Attached information	None				
Precautions/Remarks	AL status code: -, Error No.: 2903 hex				

Event name	Absolute Encoder Counter Overflow Error		Event code	38870000 hex	
Meaning	The multi-rotation counter of the encoder exceeded the maximum number of rotations.				
Source	EtherCAT Master Function Module	Source details	Slave	Detection timing	Continuously
Error attributes	Level	Minor fault	Recovery	Error reset (after cycling slave power)	Log category System log
Effects	User program	Continues.	Operation	Power drive circuit is OFF	
Indicators	EtherCAT NET RUN		EtherCAT NET ERR		EtherCAT LINK/ACT
	---		---		---
System -defined variables	Variable	Data type		Name	
	None	None		None	
Cause and correction	Assumed cause		Correction		Prevention
	An inappropriate value was set in the Encoder – Operation Selection when Using Absolute Encoder (4510-01 hex)		Set the appropriate value in the Encoder - Operation Selection when Using Absolute Encoder (4510-01 hex).		Set the appropriate value in the Encoder - Operation Selection when Using Absolute Encoder (4510-01 hex).
	The multi-rotation number of the encoder exceeded the maximum number of rotations		Set the travel distance so that the multi-rotation number does not exceed the maximum number of rotations.		Set the travel distance so that the multi-rotation number does not exceed the maximum number of rotations.
Attached information	None				
Precautions/Remarks	AL status code: -, Error No.: 4100 hex				

Event name	Safety Communications Setting Error		Event code	3888 0000 hex	
Meaning	Safety process data communications were not established with the Safety CPU Unit because of an incorrect communications setting.				
Source	EtherCAT Master Function Module		Source details	Slave	Detection timing
		Minor fault			When establishing FSoE communications
Error attributes	Level	Minor fault	Recovery	Error reset (after resetting slave errors)	Log category
					System log
Effects	User program	Continues.	Operation	Power drive circuit is OFF	
Indicators	EtherCAT NET RUN		EtherCAT NET ERR		EtherCAT LINK/ACT
	---		---		---
System-defined variables	Variable	Data type	Name		
	None	None	None		
Cause and correction	Assumed cause		Correction		Prevention
	The watchdog time was set incorrectly		If the watchdog time of the safety process data communications setting is set to a value inappropriate for the communications cycle or the configuration, correct it, and transfer the setting to the Safety CPU Unit.		Set the watchdog time in consideration of the actual configuration and surrounding environment.
The processing was not completed within the watchdog time because communications were not established due to the noise		If there is no improvement after you performed noise countermeasures, set the longer watchdog time, and transfer the setting to the Safety CPU Unit.			
Attached information	None				
Precautions/Remarks	AL status code: -, Error No.: 7001 hex				

Event name	Safety Frame Error		Event code	38890000 hex		
Meaning	Safety process data communications were not established with the Safety CPU Unit because an incorrect frame was received.					
Source	EtherCAT Master Function Module		Source details	Slave	Detection timing	When establishing FSoE communications
Error attributes	Level	Minor fault	Recovery	Error reset (after resetting slave errors)	Log category	System log
Effects	User program	Continues.	Operation	Power drive circuit is OFF		
Indicators	EtherCAT NET RUN		EtherCAT NET ERR		EtherCAT LINK/ACT	
	---		---		---	
System -defined variables	Variable	Data type		Name		
	None	None		None		
Cause and correction	Assumed cause		Correction		Prevention	
	An incorrect frame was received in safety process data communications		The Servo Drive model does not match the safety slave model that is sent from the safety master. Check the connection configuration and configure it correctly.		Set the system configuration and setup according to the corrections that are given on the left.	
	There is excessive noise		Take noise countermeasures.		Take noise countermeasures if excessive noise caused the error.	
Attached information	None					
Precautions/Remarks	AL status code: -, Error No.: 7003 hex					

Event name	Safety Parameter Error		Event code	388A0000 hex		
Description	Safety process data communications were not established with the Safety CPU Unit because an incorrect parameter was received.					
Source	EtherCAT Master Function Module		Source details	Slave	Detection timing	When establishing FSoE communications
Error attributes	Level	Minor fault	Recovery	Error reset (after resetting slave errors)	Log category	System log
Effects	User program	Continues.	Operation	Power drive circuit is OFF		
Indicators	EtherCAT NET RUN		EtherCAT NET ERR		EtherCAT LINK/ACT	
	---		---		---	
System -defined variables	Variable	Data type		Name		
	None	None		None		
Cause and correction	Assumed cause		Correction		Prevention	
	The set safety slave model is incorrect		Check whether the connected safety slave model matches the safety slave model that is set from the Sysmac Studio, and correct it.		Set the correct safety slave model that matches the actual connection configuration.	
Attached information	None					
Precautions/Remarks	AL status code: -, Error No.: 7000 hex					

Event name	FSoE Slave Address Error		Event code	388B0000 hex		
Description	Safety process data communications were not established with the Safety CPU Unit because of an incorrect FSoE slave address.					
Source	EtherCAT Master Function Module		Source details	Slave	Detection timing	When establishing FSoE communications
Error attributes	Level	Minor fault	Recovery	Error reset (after resetting slave errors)	Log category	System log
Effects	User program	Continues.	Operation	Power drive circuit is OFF		
Indicators	EtherCAT NET RUN		EtherCAT NET ERR		EtherCAT LINK/ACT	
	---		---		---	
System-defined variables	Variable	Data type		Name		
	None	None		None		
Cause and correction	Assumed cause		Correction		Prevention	
	The setting of the FSoE slave address in the safety process data communications settings is different from the setting in the Unit		Perform the FSoE Slave Address Clear for the Servo Drive.		If you use a Servo Drive for which safety process data communications were previously established in another system, perform the FSoE Slave Address Clear before you use the Servo Drive.	
Attached information	None					
Precautions/Remarks	AL status code: -, Error No.: 7002 hex					

Event name	FPGA WDT Error		Event code	48080000 hex		
Description	An FPGA error was detected.					
Source	EtherCAT Master Function Module		Source details	Slave	Detection timing	Continuously
Error attributes	Level	Minor fault	Recovery	Error reset (after cycling slave power)	Log category	System log
Effects	User program	Continues.	Operation	Power drive circuit is OFF		
Indicators	EtherCAT NET RUN		EtherCAT NET ERR		EtherCAT LINK/ACT	
	---		---		---	
System-defined variables	Variable	Data type		Name		
	None	None		None		
Cause and correction	Assumed cause		Correction		Prevention	
	False detection due to a data read error that was caused by excessive noise		If this event does not occur after you cycled the power supply, use the product continuously. It is supposed that a temporary error occurred due to a read error. If this event occurs again, the hardware is faulty. Replace the Servo Drive.		If the normal operation can restart after you cycled the power supply, consider noise countermeasures. There may be excessive noise around the Servo Drive.	
Hardware failure						
Attached information	Attached information 1: System information					
Precautions/Remarks	AL status code: -, Error No.: 3500 hex					

Event name	Drive Prohibition Input Error		Event code	64E30000 hex	
Description	Both the Positive Drive Prohibition (POT) and the Negative Drive Prohibition Input (NOT) turned ON.				
Source	EtherCAT Master Function Module	Source details	Slave	Detection timing	Continuously
Error attributes	Level	Minor fault	Recovery	Error reset (after resetting slave errors)	Log category System log
Effects	User program	Continues.	Operation	Power drive circuit is OFF	
Indicators	EtherCAT NET RUN		EtherCAT NET ERR		EtherCAT LINK/ACT
	---		---		---
System -defined variables	Variable	Data type		Name	
	None	None		None	
Cause and correction	Assumed cause	Correction		Prevention	
	An error occurred on the switch, wire, power supply, and wiring that were connected to the Positive Drive Prohibition (POT) or Negative Drive Prohibition Input (NOT)	Check and correct an error on the switch, wire, power supply, and wiring that were connected to the Positive Drive Prohibition Input or Negative Drive Prohibition Input.		Confirm that there are not disconnection and incorrect logic setting, and use the Drive Prohibition Input.	
	False detection occurred because the control signal power supply was turned ON slowly	Check whether the control signal power supply (12 to 24 VDC) is turned ON slowly, and adjust the timing if it is slow.		Adjust the timing at which the control signal power supply is turned ON so that the signal can be input correctly.	
Attached information	None				
Precautions/Remarks	AL status code: -, Error No.: 3800 hex				

Event name	Drive Prohibition Detected		Event code	68200000 hex	
Description	The operation was stopped according to the user setting because the motor ran in the prohibited direction when the Drive Prohibition was enabled.				
Source	EtherCAT Master Function Module		Source details	Slave	Detection timing Continuously
Error attributes	Level	Minor fault	Recovery	Error reset (after resetting slave errors)	Log category System log
Effects	User program	Continues.	Operation	Power drive circuit is OFF	
Indicators	EtherCAT NET RUN		EtherCAT NET ERR		EtherCAT LINK/ACT
	---		---		---
System-defined variables	Variable		Data type		Name
	None		None		None
Cause and correction	Assumed cause		Correction		Prevention
	Incorrect or broken wiring of Positive Drive Prohibition Input (POT) or Negative Drive Prohibition Input (NOT)		Correct the wiring if the Positive Drive Prohibition Input (POT) or Negative Drive Prohibition Input (NOT) is wired incorrectly. If the cable is broken, replace it.		Confirm that the Positive Drive Prohibition Input (POT) and Negative Drive Prohibition Input (NOT) are wired correctly. Confirm that the cable is not broken before use.
	Incorrect setting of the Drive Prohibition Input		Review the setting of the drive prohibition input port and set it correctly.		Configure the setting of the drive prohibition input port to be appropriate for the actual connection condition.
Attached information	Attached information 1: System information				
Precautions/Remarks	AL status code: -, Error No.: 3801 hex				

Event name	Control Right Release Error		Event code	68210000 hex	
Description	Communications between the Sysmac Studio and Servo Drive were interrupted while a specific function was used from the Sysmac Studio.				
Source	EtherCAT Master Function Module	Source details	Slave	Detection timing	Continuously
Error attributes	Level	Minor fault	Recovery	Error reset (after resetting slave errors)	Log category System log
Effects	User program	Continues.	Operation	Power drive circuit is OFF	
Indicators	EtherCAT NET RUN		EtherCAT NET ERR		EtherCAT LINK/ACT
	---		---		---
System -defined variables	Variable	Data type		Name	
	None	None		None	
Cause and correction	Assumed cause		Correction		Prevention
	The USB cable or EtherCAT cable was disconnected during the connection with the Sysmac Studio		Connect the USB cable or EtherCAT cable between the Servo Drive and the computer that controls the Servo Drive if it is disconnected.		Do not disconnect the cable during the operation of Sysmac Studio.
	There is excessive noise		Take noise countermeasures for the USB cable or EtherCAT cable.		Use the recommended USB cable or EtherCAT cable.
	A command sent from the Sysmac Studio was not sent to the Servo Drive because the computer was in a busy state or the like		Finish other applications to reduce the processing load of the computer.		Do not use the Sysmac Studio with more than one application active so that the computer does not go into a busy state.
Attached information	None				
Precautions/Remarks	AL status code: -, Error No.: 6200 hex				

Event name	Error Stop Input		Event code	6822 0000 hex	
Meaning	The Error Stop Input (ESTP) is active.				
Source	EtherCAT Master Function Module		Source details	Slave	Detection timing
Error attributes	Level	Minor fault	Recovery	Error reset (after resetting slave errors)	Log category
Effects	User program	Continues.	Operation	Power drive circuit is OFF	
Indicators	EtherCAT NET RUN		EtherCAT NET ERR		EtherCAT LINK/ACT
	---		---		---
System-defined variables	Variable		Data type		Name
	None		None		None
Cause and correction	Assumed cause		Correction		Prevention
	The Error Stop Input (ESTP) was input		Remove the cause of Error Stop Input (ESTP).		A preventative measure is not required because the purpose is to detect an error.
	The Error Stop Input (ESTP) is incorrectly wired		Correct the wiring if the Error Stop Input (ESTP) is incorrectly wired.		Confirm that the Error Stop Input (ESTP) is correctly wired.
Attached information	None				
Precautions/Remarks	AL status code: -, Error No.: 8700 hex				

Event name	Software Limit Exceeded		Event code	6823 0000 hex	
Description	The Position actual value detected the position that exceeded the value set in the Software Position Limit, and stopped the operation according to the user setting.				
Source	EtherCAT Master Function Module		Source details	Slave	Detection timing
Error attributes	Level	Minor fault	Recovery	Error reset (after resetting slave errors)	Log category
Effects	User program	Continues.	Operation	Power drive circuit is OFF	
Indicators	EtherCAT NET RUN		EtherCAT NET ERR		EtherCAT LINK/ACT
	---		---		---
System-defined variables	Variable		Data type		Name
	None		None		None
Cause and correction	Assumed cause		Correction		Prevention
	Incorrect setting of Software Position Limit		Correct the setting of Software Position Limit.		Confirm that the setting of Software Position Limit is correct.
	When the Software Position Limit - Stop Selection was set to <i>Stop according to the setting of Fault reaction option code</i> , the position exceeded the value set in the Software Position Limit		Set the command value to be within the range of Software Position Limit.		Set the command value to be within the range of Software Position Limit.
Attached information	None				
Precautions/Remarks	AL status code: -, Error No.: 3401 hex				

Event name	Pulse Output Overspeed Error		Event code	7820 0000 hex	
Description	The speed, which exceeded the frequency that could be output by the Encoder Dividing Pulse Output function, was detected.				
Source	EtherCAT Master Function Module	Source details	Slave	Detection timing	Continuously
Error attributes	Level	Minor fault	Recovery	Error reset (after resetting slave errors)	Log category System log
Effects	User program	Continues.	Operation	Power drive circuit is OFF	
Indicators	EtherCAT NET RUN		EtherCAT NET ERR		EtherCAT LINK/ACT
	---		---		---
System -defined variables	Variable	Data type		Name	
	None	None		None	
Cause and correction	Assumed cause		Correction		Prevention
	The dividing ratio setting is inappropriate for the actual usage condition		Correct the setting of Encoder Dividing Pulse Output - Dividing Denominator and Dividing Numerator.		Set the Encoder Dividing Pulse Output - Dividing Denominator and Dividing Numerator to a value appropriate for the maximum speed that is detected during operation.
Attached information	None				
Precautions/ Remarks	AL status code: -, Error No.: 2800 hex				

Event name	Brake Interlock Error		Event code	7821 0000 hex	
Description	The Brake Interlock Output (BKIR) was output by the Timeout at Servo OFF.				
Source	EtherCAT Master Function Module	Source details	Slave	Detection timing	Continuously
Error attributes	Level	Minor fault	Recovery	Error reset (after resetting slave errors)	Log category System log
Effects	User program	Continues.	Operation	Power drive circuit is OFF	
Indicators	EtherCAT NET RUN		EtherCAT NET ERR		EtherCAT LINK/ACT
	---		---		---
System -defined variables	Variable	Data type		Name	
	None	None		None	
Cause and correction	Assumed cause		Correction		Prevention
	The Brake Interlock Output (BKIR) was output because the motor rotation speed did not decrease to or less than the speed set in the Threshold Speed at Servo OFF within the time set in the Timeout at Servo OFF when Servo OFF was performed during the motor operation		Increase the setting of the Timeout at Servo OFF according to actual operation conditions.		Confirm the corrections that are given on the left before use.
Attached information	None				
Precautions/ Remarks	AL status code: -, Error No.: 9700 hex				

Event name	Command Error		Event code	7823 0000 hex		
Meaning	A mistake was made in using a command.					
Source	EtherCAT Master Function Module		Source details	Slave	Detection timing	Continuously
Error attributes	Level	Minor fault	Recovery	Error reset	Log category	System log
Effects	User program	Continues.	Operation	Power drive circuit is OFF		
Indicators	EtherCAT NET RUN		EtherCAT NET ERR		EtherCAT LINK/ACT	
	---		---		---	
System-defined variables	Variable		Data type		Name	
	None		None		None	
Cause and correction	Assumed cause		Correction		Prevention	
	When bit 9 (Remote) of the Statusword was set to 1 (remote), and the Servo Drive was in <i>Operation enabled</i> state (Servo ON), the Servo Drive received a command to change the communications state from Operational to another state (Init, Pre-Operational, or Safe-Operational)		Check the Servo Drive specifications and use the command correctly.		Check the Servo Drive specifications and use the command correctly.	
	A mode of operation other than the hm mode was set during the homing operation					
	Modes of operation was set to pp, pv or hm mode when the communications period was set to shorter than 250 μs					
Attached information	None					
Precautions/Remarks	AL status code: -, Error No.: 9101 hex					

Event name	EtherCAT State Change Error		Event code	84B10000 hex	
Description	A communications state change command was received for which the current communications state could not be changed.				
Source	EtherCAT Master Function Module	Source details	Slave	Detection timing	Continuously
Error attributes	Level	Minor fault	Recovery	Error reset (after resetting slave errors)	Log category System log
Effects	User program	Continues.	Operation	Power drive circuit is OFF	
Indicators	EtherCAT NET RUN		EtherCAT NET ERR		EtherCAT LINK/ACT
	---		---		---
System -defined variables	Variable	Data type		Name	
	None	None		None	
Cause and correction	Assumed cause		Correction		Prevention
	A communications state change command was received for which the current communications state could not be changed		Check the command specifications for communications state transitions in the host controller and correct host controller processing.		Check the command specifications for communications state transitions in the host controller and program host controller processing.
Attached information	None				
Precautions/Remarks	AL status code: 0011 hex, Error No.: 8301 hex				

Event name	EtherCAT Illegal State Change Error		Event code	84B20000 hex	
Description	An undefined communications state change command was received.				
Source	EtherCAT Master Function Module	Source details	Slave	Detection timing	Continuously
Error attributes	Level	Minor fault	Recovery	Error reset (after resetting slave errors)	Log category System log
Effects	User program	Continues.	Operation	Power drive circuit is OFF	
Indicators	EtherCAT NET RUN		EtherCAT NET ERR		EtherCAT LINK/ACT
	---		---		---
System -defined variables	Variable	Data type		Name	
	None	None		None	
Cause and correction	Assumed cause		Correction		Prevention
	An undefined communications state change command was received		Check the command specifications for communications state transitions in the host controller and correct host controller processing.		Check the command specifications for communications state transitions in the host controller and program host controller processing.
Attached information	None				
Precautions/Remarks	AL status code: 0012 hex, Error No.: 8302 hex				

Event name	Synchronization Error		Event code	84B40000 hex	
Description	A signal for synchronous communications could not be detected.				
Source	EtherCAT Master Function Module		Source details	Slave	Detection timing Continuously
Error attributes	Level	Minor fault	Recovery	Error reset (after resetting slave errors) ^{*1}	Log category System log
Effects	User program	Continues.	Operation	Power drive circuit is OFF	
Indicators	EtherCAT NET RUN		EtherCAT NET ERR		EtherCAT LINK/ACT
	---		---		---
System-defined variables	Variable		Data type		Name
	None		None		None
Cause and correction	Assumed cause		Correction		Prevention
	Noise		Take noise countermeasures if excessive noise affects the EtherCAT communications cable.		Take noise countermeasures if excessive noise affects the EtherCAT communications cable.
	Error of the EtherCAT slave communications controller		If this event occurs again after you cycled the power supply, replace the Servo Drive.		None
Attached information	None				
Precautions/Remarks	AL status code: 002C hex, Error No.: 8304 hex				

*1. "Error reset (after cycling slave power)" is specified for the unit version 1.0.

Event name	Sync Manager WDT Error		Event code	84B50000 hex	
Description	PDO communications were interrupted for the allowable period or longer.				
Source	EtherCAT Master Function Module		Source details	Slave	Detection timing Continuously
Error attributes	Level	Minor fault	Recovery	Error reset (after resetting slave errors)	Log category System log
Effects	User program	Continues.	Operation	Power drive circuit is OFF	
Indicators	EtherCAT NET RUN		EtherCAT NET ERR		EtherCAT LINK/ACT
	---		---		---
System-defined variables	Variable		Data type		Name
	None		None		None
Cause and correction	Assumed cause		Correction		Prevention
	An EtherCAT communications cable is disconnected, loose, or broken		Connect the EtherCAT communications cable securely.		Connect the EtherCAT communications cable securely.
	Host controller error		Check the operation of the host controller. Take appropriate countermeasures if there is a problem.		None
Attached information	None				
Precautions/Remarks	AL status code: 001B hex, Error No.: 8305 hex				

Event name	ESC Initialization Error		Event code	84B60000 hex		
Description	The initialization of EtherCAT slave communications controller failed.					
Source	EtherCAT Master Function Module		Source details	Slave	Detection timing	At power ON
Error attributes	Level	Minor fault	Recovery	Error reset (after cycling slave power)	Log category	System log
Effects	User program	Continues.	Operation	Power drive circuit is OFF		
Indicators	EtherCAT NET RUN		EtherCAT NET ERR		EtherCAT LINK/ACT	
	---		---		---	
System -defined variables	Variable	Data type		Name		
	None	None		None		
Cause and correction	Assumed cause		Correction		Prevention	
	Data was incorrectly overwritten in the non-volatile memory of the EtherCAT slave communications controller		If this event does not occur after you cycled the power supply, use the product continuously. It is supposed that a temporary error occurred due to a read error. If this event occurs again, replace the Servo Drive.		None	
	Failure of the EtherCAT slave communications controller					
Attached information	None					
Precautions/Remarks	AL status code: -, Error No.: 8801 hex					

Event name	SII Verification Error		Event code	84B70000 hex		
Description	An error occurred in SII data of the EtherCAT slave communications controller.					
Source	EtherCAT Master Function Module		Source details	Slave	Detection timing	At power ON
Error attributes	Level	Minor fault	Recovery	Error reset (after cycling slave power)	Log category	System log
Effects	User program	Continues.	Operation	Power drive circuit is OFF		
Indicators	EtherCAT NET RUN		EtherCAT NET ERR		EtherCAT LINK/ACT	
	---		---		---	
System -defined variables	Variable	Data type		Name		
	None	None		None		
Cause and correction	Assumed cause		Correction		Prevention	
	Data was incorrectly overwritten in the non-volatile memory of the EtherCAT slave communications controller		If this event does not occur after you cycled the power supply, use the product continuously. It is supposed that a temporary error occurred due to a read error. If this event occurs again, replace the Servo Drive.		None	
	Failure of the EtherCAT slave communications controller or false detection					
Attached information	None					
Precautions/Remarks	AL status code: 0014 hex, Error No.: 8803 hex					

Event name	Synchronization Interruption Error		Event code	84B90000 hex	
Description	Synchronization interruption did not occur within the specified period.				
Source	EtherCAT Master Function Module		Source details	Slave	Detection timing Continuously
Error attributes	Level	Minor fault	Recovery	Error reset (after cycling slave power)	Log category System log
Effects	User program	Continues.	Operation	Power drive circuit is OFF	
Indicators	EtherCAT NET RUN		EtherCAT NET ERR		EtherCAT LINK/ACT
	---		---		---
System-defined variables	Variable		Data type		Name
	None		None		None
Cause and correction	Assumed cause		Correction		Prevention
	Incorrect EtherCAT synchronization setting of the host controller		Set the synchronization setting of the host controller according to the synchronization specifications for the EtherCAT slave.		Confirm the synchronization specifications for the EtherCAT slave, and configure the synchronization setting from the host controller correctly.
	Failure of the EtherCAT slave communications controller or false detection		If this event does not occur after you cycled the power supply, use the product continuously. It is supposed that a temporary error occurred due to a read error. If this event occurs again, the Servo Drive is faulty. Replace the Servo Drive.		None
Attached information	None				
Precautions/Remarks	AL status code: 002D hex, Error No.: 8802 hex				

Event name	Bootstrap State Transition Request Error		Event code	84BA0000 hex	
Description	The state transition to unsupported Bootstrap was requested.				
Source	EtherCAT Master Function Module		Source details	Slave	Detection timing Continuously
Error attributes	Level	Minor fault	Recovery	Error reset	Log category System log
Effects	User program	Continues.	Operation	Power drive circuit is OFF	
Indicators	EtherCAT NET RUN		EtherCAT NET ERR		EtherCAT LINK/ACT
	---		---		---
System-defined variables	Variable		Data type		Name
	None		None		None
Cause and correction	Assumed cause		Correction		Prevention
	The EtherCAT master requested the transition of unsupported Bootstrap		Check the EtherCAT master setting so that the EtherCAT master does not request the transition to Bootstrap.		Check the EtherCAT master setting so that the EtherCAT master does not request the transition to Bootstrap.
Attached information	None				
Precautions/Remarks	AL status code: 0013 hex, Error No.: 8306 hex				

Event name	Communications Synchronization Error		Event code	88100000 hex	
Meaning	Communications were not established consecutively because the synchronization with the EtherCAT Master could not be achieved.				
Source	EtherCAT Master Function Module	Source details	Slave	Detection timing	Continuously
Error attributes	Level	Minor fault	Recovery	Error reset (after resetting slave errors)	Log category System log
Effects	User program	Continues.	Operation	Power drive circuit is OFF	
Indicators	EtherCAT NET RUN		EtherCAT NET ERR		EtherCAT LINK/ACT
	---		---		---
System-defined variables	Variable	Data type		Name	
	None	None		None	
Cause and correction	Assumed cause		Correction		Prevention
	The power supply to the host controller was interrupted during PDO communications		Reset the error in the host controller. This event reports an error that was detected when the power supply to the host controller was interrupted. It does not indicate that an error currently exists.		If you turn OFF the power supply to the host controller, also turn OFF the power supply to the Servo Drive.
	An EtherCAT communications cable is disconnected, loose, broken, or has a contact failure		Connect the EtherCAT communications cable securely. If the cable is broken, replace it.		Connect the EtherCAT communications cable securely.
	Noise		Take noise countermeasures if excessive noise affects the EtherCAT communications cable.		Take noise countermeasures if excessive noise affects the EtherCAT communications cable.
Attached information	None				
Precautions/Remarks	AL status code: 0034 hex, Error No.: 8303 hex				

Event name	Safety Communications Timeout		Event code	88120000 hex		
Meaning	A communications timeout occurred in safety process data communications with the Safety CPU Unit.					
Source	EtherCAT Master Function Module		Source details	Slave	Detection timing	When establishing FSoE communications/during FSoE communications
Error attributes	Level	Minor fault	Recovery	Error reset (after resetting slave errors)	Log category	System log
Effects	User program	Continues.	Operation	Power drive circuit is OFF		
Indicators	EtherCAT NET RUN		EtherCAT NET ERR		EtherCAT LINK/ACT	
	---		---		---	
System-defined variables	Variable		Data type		Name	
	None		None		None	
Cause and correction	Assumed cause		Correction		Prevention	
	A setting is not correct. The setting of the safety task period of the Safety CPU Unit is too short		Increase the safety task period of the Safety CPU Unit and then transfer the settings to the Safety CPU Unit.		Set the system configuration and setup according to the corrections that are given on the left.	
	There is excessive noise		Take noise countermeasures.		Take noise countermeasures if excessive noise caused the error.	
	The Safety CPU Unit or safety slave entered a status where it could not continue safety process data communications		Check the status of the Safety CPU Unit or safety slave.		Refer to troubleshooting information for the Safety CPU Unit or safety slave.	
Attached information	None					
Precautions/Remarks	AL status code: -, Error No.: 7004 hex					

Event name	Absolute Value Cleared		Event code	98200000 hex		
Meaning	The multi-rotation counter of the absolute encoder was cleared.					
Source	EtherCAT Master Function Module		Source details	Slave	Detection timing	Continuously
Error attributes	Level	Minor fault	Recovery	Error reset (after cycling slave power)	Log category	System log
Effects	User program	Continues.	Operation	Power drive circuit is OFF		
Indicators	EtherCAT NET RUN		EtherCAT NET ERR		EtherCAT LINK/ACT	
	---		---		---	
System-defined variables	Variable		Data type		Name	
	None		None		None	
Cause and correction	Assumed cause		Correction		Prevention	
	The multi-rotation counter of the absolute encoder was cleared		This operation is performed for safety and is not an error.		A preventative measure is not required because this is a safety measure.	
Attached information	None					
Precautions/Remarks	AL status code: -, Error No.: 2701 hex					

Event name	Capacitor Lifetime Warning		Event code	081C0000 hex		
Meaning	The capacitor built into the Servo Drive reached the service life of the manufacturer's guarantee.					
Source	EtherCAT Master Function Module		Source details	Slave	Detection timing	Continuously
Error attributes	Level	Observation ^{*1}	Recovery	---	Log category	System log
Effects	User program	Continues.	Operation	Not affected.		
Indicators	EtherCAT NET RUN		EtherCAT NET ERR		EtherCAT LINK/ACT	
	---		---		---	
System-defined variables	Variable		Data type		Name	
	None		None		None	
Cause and correction	Assumed cause		Correction		Prevention	
	The operating time of the capacitor in the Servo Drive exceeded the service life		Send the Servo Drive for repair or replace the Servo Drive with a new one. It is necessary to replace the component that reached the service life.		None	
Attached information	None					
Precautions/Remarks	AL status code: -, Error No.: A701 hex					

*1. You can change the level to minor fault by using Warning Level Change 1 Selection (4020-05 hex).

Event name	Inrush Current Prevention Relay Lifetime Warning		Event code	081D0000 hex		
Description	The inrush current prevention relay built into the Servo Drive reached the service life of the manufacturer's guarantee.					
Source	EtherCAT Master Function Module		Source details	Slave	Detection timing	Continuously
Error attributes	Level	Observation ^{*1}	Recovery	---	Log category	System log
Effects	User program	Continues.	Operation	Not affected.		
Indicators	EtherCAT NET RUN		EtherCAT NET ERR		EtherCAT LINK/ACT	
	---		---		---	
System-defined variables	Variable		Data type		Name	
	None		None		None	
Cause and correction	Assumed cause		Correction		Prevention	
	The number of operating times of the inrush current prevention relay in the Servo Drive exceeded the service life		Send the Servo Drive for repair or replace the Servo Drive with a new one. It is necessary to replace the component that reached the service life.		None	
Attached information	None					
Precautions/Remarks	AL status code: -, Error No.: A702 hex					

*1. You can change the level to minor fault by using Warning Level Change 1 Selection (4020-05 hex).

Event name	Brake Interlock Output Relay Lifetime Warning		Event code	081F0000 hex		
Description	The brake interlock output (BKIR) relay built into the Servo Drive reached the service life of the manufacturer's guarantee.					
Source	EtherCAT Master Function Module		Source details	Slave	Detection timing	Continuously
Error attributes	Level	Observation ^{*1}	Recovery	---	Log category	System log
Effects	User program	Continues.	Operation	Not affected.		
Indicators	EtherCAT NET RUN		EtherCAT NET ERR		EtherCAT LINK/ACT	
	---		---		---	
System-defined variables	Variable		Data type		Name	
	None		None		None	
Cause and correction	Assumed cause		Correction		Prevention	
	The number of operating times of the brake interlock output in the Servo Drive exceeded the service life		Send the Servo Drive for repair or replace the Servo Drive with a new one. It is necessary to replace the component that reached the service life.		None	
Attached information	None					
Precautions/Remarks	AL status code: -, Error No.: A704 hex					

*1. You can change the level to minor fault by using Warning Level Change 1 Selection (4020-05 hex).

Event name	Encoder Communications Warning		Event code	083A0000 hex	
Description	Encoder communications errors occurred in series more frequently than the specified value.				
Source	EtherCAT Master Function Module	Source details	Slave	Detection timing	Continuously
Error attributes	Level	Observation ^{*1}	Recovery	---	Log category
Effects	User program	Continues.	Operation	Not affected.	
Indicators	EtherCAT NET RUN		EtherCAT NET ERR		EtherCAT LINK/ACT
	---		---		---
System-defined variables	Variable	Data type		Name	
	None	None		None	
Cause and correction	Assumed cause	Correction		Prevention	
	Noise into the encoder cable	<ul style="list-style-type: none"> Separate the motor cable and the encoder cable if they are bundled together. Connect the shield to FG. Check that the motor ground wire is connected to FG. 		<ul style="list-style-type: none"> Separate the motor cable and the encoder cable if they are bundled together. Connect the shield to FG. Confirm that the motor ground wire is connected to FG. 	
	Contact failure of the encoder cable	Check whether the connector is disconnected. Connect the connector securely if it is disconnected or loose. Check that the encoder cable is not broken. Replace the encoder cable if it is broken.		Confirm that the connector is connected. Use the recommended cable and periodically check that the encoder cable is not broken.	
	Power supply undervoltage to the encoder	Use the recommended encoder cable.		Use the recommended encoder cable.	
Attached information	Attached information 1: System information				
Precautions/Remarks	AL status code: -, Error No.: A400 hex				

*1. You can change the level to minor fault by using Warning Level Change 1 Selection (4020-05 hex).

Event name	Encoder Lifetime Warning		Event code	0847 0000 hex		
Description	The encoder lifetime is close to the end.					
Source	EtherCAT Master Function Module	Source details	Slave	Detection timing	Continuously	
Error attributes	Level	Observation ^{*1}	Recovery	---	Log category	System log
Effects	User program	Continues.	Operation	Not affected.		
Indicators	EtherCAT NET RUN		EtherCAT NET ERR		EtherCAT LINK/ACT	
	---		---		---	
System-defined variables	Variable		Data type		Name	
	None		None		None	
Cause and correction	Assumed cause		Correction		Prevention	
	Temporary noise		If this event occurs repeatedly, the lifetime is close to the end. Replace the motor.		None	
	The end of the encoder life					
Attached information	None					
Precautions/Remarks	AL status code: -, Error No.: A706 hex					

*1. You can change the level to minor fault by using Warning Level Change 1 Selection (4020-05 hex).

Event name	Fan Rotation Warning		Event code	084C 0000 hex		
Description	The rotation speed of the fan is 80% or less of the rating and the cooling performance decreases.					
Source	EtherCAT Master Function Module	Source details	Slave	Detection timing	Continuously	
Error attributes	Level	Observation ^{*1}	Recovery	---	Log category	System log
Effects	User program	Continues.	Operation	Not affected.		
Indicators	EtherCAT NET RUN		EtherCAT NET ERR		EtherCAT LINK/ACT	
	---		---		---	
System-defined variables	Variable		Data type		Name	
	None		None		None	
Cause and correction	Assumed cause		Correction		Prevention	
	There is a foreign matter in the cooling fan and it blocks the rotation		Check whether there is a foreign matter in the fan. If you find a foreign matter, remove it. If there is no improvement after you performed the correction above, replace the Servo Drive.		Do not use the fan in an area surrounded by excessive foreign matter. Also, do not allow foreign matter to enter.	
	Cooling fan failure					
Attached information	None					
Precautions/Remarks	AL status code: -, Error No.: A300 hex					

*1. You can change the level to minor fault by using Warning Level Change 1 Selection (4020-05 hex).

Event name	Absolute Encoder Counter Overflow Warning		Event code	084E0000 hex	
Description	The multi-rotation counter of the encoder exceeded the value set in Encoder - Absolute Encoder Counter Overflow Warning Level (4510-02 hex) .				
Source	EtherCAT Master Function Module	Source details	Slave	Detection timing	Continuously
Error attributes	Level	Observation ^{*1}	Recovery	---	Log category System log
Effects	User program	Continues.	Operation	Not affected.	
Indicators	EtherCAT NET RUN		EtherCAT NET ERR		EtherCAT LINK/ACT
	---		---		---
System -defined variables	Variable	Data type		Name	
	None	None		None	
Cause and correction	Assumed cause	Correction		Prevention	
	An inappropriate value was set in the Encoder – Operation Selection when Using Absolute Encoder (4510-01 hex)	Set an appropriate value in the Encoder - Operation Selection when Using Absolute Encoder (4510-01 hex) .		Set an appropriate value in the Encoder - Operation Selection when Using Absolute Encoder (4510-01 hex) .	
	The multi-rotation number of the encoder exceeded the warning level	Set the travel distance so that the multi-rotation number does not exceed the value set in the Encoder - Absolute Encoder Counter Overflow Warning Level (4510-02 hex) .		Set the travel distance so that the multi-rotation number does not exceed the value set in the Encoder - Absolute Encoder Counter Overflow Warning Level (4510-02 hex) .	
Attached information	None				
Precautions/Remarks	AL status code: -, Error No.: AB00 hex				

*1. You can change the level to minor fault by using Warning Level Change 1 Selection (4020-05 hex).

Event name	Lifetime Information Corruption Warning		Event code	18390000 hex		
Description	An error was detected in the saved lifetime information.					
Source	EtherCAT Master Function Module		Source details	Slave	Detection timing	At power ON
Error attributes	Level	Observation ^{*1}	Recovery	---	Log category	System log
Effects	User program	Continues.	Operation	Not affected.		
Indicators	EtherCAT NET RUN		EtherCAT NET ERR		EtherCAT LINK/ACT	
	---		---		---	
System-defined variables	Variable		Data type		Name	
	None		None		None	
Cause and correction	Assumed cause		Correction		Prevention	
	The lifetime information corruption was detected when the power supply was turned ON		Perform the Lifetime Information Clear. Note that the lifetime may not be detected correctly after the clear operation because the value of lifetime information is cleared. If this event occurs repeatedly, the area to save lifetime information is faulty. Replace the Servo Drive.		None	
Attached information	None					
Precautions/Remarks	AL status code: -, Error No.: A705 hex					

*1. You can change the level to minor fault by using Warning Level Change 1 Selection (4020-05 hex).

Event name	Data Setting Warning		Event code	34E00000 hex		
Description	The object set value is out of the range.					
Source	EtherCAT Master Function Module		Source details	Slave	Detection timing	Continuously
Error attributes	Level	Observation ^{*1}	Recovery	---	Log category	System log
Effects	User program	Continues.	Operation	Not affected.		
Indicators	EtherCAT NET RUN		EtherCAT NET ERR		EtherCAT LINK/ACT	
	---		---		---	
System-defined variables	Variable		Data type		Name	
	None		None		None	
Cause and correction	Assumed cause		Correction		Prevention	
	The object set value is out of the range		Correct the object setting to be within the specified range.		Correct the object setting to be within the specified range.	
Attached information	None					
Precautions/Remarks	AL status code: -, Error No.: B000 hex					

*1. You can change the level to minor fault by using Warning Level Change 1 Selection (4020-05 hex).

Event name	Overload Warning		Event code	387A0000 hex		
Description	The Load Ratio of Servo Drive or motor (4150-81 hex) exceeded the level set in the Overload - Warning Notification Level (4150-01 hex).					
Source	EtherCAT Master Function Module		Source details	Slave	Detection timing	Continuously
Error attributes	Level	Observation ^{*1}	Recovery	---	Log category	System log
Effects	User program	Continues.	Operation	Not affected.		
Indicators	EtherCAT NET RUN		EtherCAT NET ERR		EtherCAT LINK/ACT	
	---		---		---	
System-defined variables	Variable	Data type		Name		
	None	None		None		
Cause and correction	Assumed cause	Correction		Prevention		
	Operation was continued for a long time with high load.	Perform the following corrections accordingly. <ul style="list-style-type: none"> • Increase the set value of the acceleration/deceleration time and the stop time. • Lighten the load. • Adjust the gain or inertia ratio. • If torque waveforms oscillate excessively, adjust the system by the tuning so that the oscillation does not occur. • Set the appropriate brake timing. • Increase the capacities of the Servo Drive and the motor. 		Check the items given for corrections in advance and take countermeasures as required.		
	There is incorrect wiring of the motor cable or a broken cable	<ul style="list-style-type: none"> • Connect the motor cable as shown in the wiring diagram. If the cable is broken, replace it. Or, connect the motor cable and encoder cable that are used together to the same motor. • Measure the voltage at the brake terminal. If the brake is applied, release it. 		Connect the motor cable as shown in the wiring diagram. Connect the motor cable and encoder cable/external encoder cable that are used together to the same motor.		
	Increase in friction	Check machine conditions and remove the cause of the friction.		Take countermeasures so that machine distortion is not generated.		
Attached information	Attached Information 1: Cause Details 1: The Servo Drive is overloaded 2: The Servomotor is overloaded					
Precautions/Remarks	AL status code: -, Error No.: A000 hex					

*1. You can change the level to minor fault by using Warning Level Change 1 Selection (4020-05 hex).

Event name	Regeneration Overload Warning		Event code	387D0000 hex	
Description	The Regeneration Load Ratio (4310-81 hex) exceeded 85% of the regeneration overload ratio.				
Source	EtherCAT Master Function Module	Source details	Slave	Detection timing	Continuously
Error attributes	Level	Observation* ¹	Recovery	---	Log category
Effects	User program	Continues.	Operation	Not affected.	
Indicators	EtherCAT NET RUN		EtherCAT NET ERR		EtherCAT LINK/ACT
	---		---		---
System-defined variables	Variable		Data type		Name
	None		None		None
Cause and correction	Assumed cause		Correction		Prevention
	The regeneration processing is set inappropriately		Check the regeneration processing setting, and set the same value as the resistance value of the Regeneration Resistor in use.		Check the items given for corrections in advance and take countermeasures as required.
	The Regeneration Resistor is selected inappropriately		Check the operation pattern by the velocity monitor. Check the load ratio of Regeneration Resistor, and perform the following corrections accordingly. <ul style="list-style-type: none"> • Increase the deceleration time and stopping time. • Decrease the command velocity to the motor. • Use an External Regeneration Resistor. • Increase the capacities of the Servo Drive and the motor. 		
	The Regeneration Resistor is used for continuous regenerative braking		The Regeneration Resistor cannot be used for continuous regenerative braking.		Do not use the Regeneration Resistor for continuous regenerative braking.
	The applied power supply voltage is higher than the specified value		Apply the power supply voltage to be the specified value.		Review the power supply voltage to be the specified value before use.
	Regeneration Resistor failure		Check whether the Regeneration Resistor is faulty, and use one without failures.		Confirm that the Regeneration Resistor is not faulty before use.
Attached information	None				
Precautions/Remarks	AL status code: -, Error No.: A100 hex				

*1. You can change the level to minor fault by using Warning Level Change 1 Selection (4020-05 hex).

Event name	Motor Vibration Warning		Event code	387E0000 hex	
Description	The motor vibration, which was higher than or equal to the level set in the Vibration Detection - Detection Level (3B70-01 hex), was detected.				
Source	EtherCAT Master Function Module		Source details	Slave	Detection timing During Servo ON
Error attributes	Level	Observation *1	Recovery	---	Log category System log
Effects	User program	Continues.	Operation	Not affected.	
Indicators	EtherCAT NET RUN		EtherCAT NET ERR		EtherCAT LINK/ACT
	---		---		---
System -defined variables	Variable		Data type		Name
	None		None		None
Cause and correction	Assumed cause		Correction		Prevention
	The control parameter is set inappropriately		Set the control parameters such as inertia ratio, gain, and filter to appropriate values by gain tuning or manually.		Set and use the appropriate control parameter.
		The rigidity decreased due to mechanical looseness or wear		Check whether the mechanical system is not loose and secure it firmly. If the rigidity of mechanical system is changed, adjust the control parameter again.	
				Secure the mechanical system firmly without the looseness.	
Attached information	None				
Precautions/Remarks	AL status code: -, Error No.: A600 hex				

*1. You can change the level to minor fault by using Warning Level Change 1 Selection (4020-05 hex).

Event name	Command Warning		Event code	7822 0000 hex		
Meaning	A command could not be executed.					
Source	EtherCAT Master Function Module		Source details	Slave	Detection timing	Continuously
Error attributes	Level	Observation ^{*1}	Recovery	---	Log category	System log
Effects	User program	Continues.	Operation	Not affected.		
Indicators	EtherCAT NET RUN		EtherCAT NET ERR		EtherCAT LINK/ACT	
	---		---		---	
System-defined variables	Variable		Data type		Name	
	None		None		None	
Cause and correction	Assumed cause		Correction		Prevention	
	The <i>Switch on</i> command was received		Send the <i>Switch on</i> command with the main circuit power supply ON.		Use the Servo Drive after confirming the corrections that are given on the left.	
	The <i>Enable operation</i> command was received		Send the <i>Enable operation</i> command under the following conditions. <ul style="list-style-type: none"> • In supported operation mode • The motor rotation speed is 30 r/min or less. • In the free-run mode, the interpolation time period is the integral multiple of the communications cycle. 			
	An operation command in the prohibition direction was received after the immediate stop by the Drive Prohibition Input or Software Position Limit		Check status of the Drive Prohibition Input and Software Position Limit by the Digital inputs, Statusword, and Software Position Limit. Then, do not issue the command in the drive prohibition direction.			
	Homing started		Set a supported number of the Homing method for homing. Start homing at the timing of when homing is not performed.			
	The positioning start command was received in the Profile position mode		Set a supported value for bit 5 and 6 in the Controlword.			
Attached information		None				
Precautions/Remarks	AL status code: -, Error No.: B100 hex					

*1. You can change the level to minor fault by using Warning Level Change 3 Selection (4020-07 hex).

Event name	EtherCAT Communications Warning		Event code	84B00000 hex	
Description	An EtherCAT communications error occurred more than one time.				
Source	EtherCAT Master Function Module	Source details	Slave	Detection timing	Continuously
Error attributes	Level	Observation ^{*1}	Recovery	---	Log category System log
Effects	User program	Continues.	Operation	Not affected.	
Indicators	EtherCAT NET RUN		EtherCAT NET ERR		EtherCAT LINK/ACT
	---		---		---
System -defined variables	Variable		Data type		Name
	None		None		None
Cause and correction	Assumed cause		Correction		Prevention
	An EtherCAT communications cable has a contact failure, or is connected incorrectly or broken		Connect the EtherCAT communications cable securely. If the cable is broken, replace it.		Confirm that the EtherCAT communications cable is not broken, and connect is securely before use.
	Noise		Take noise countermeasures so that the noise does not affect the EtherCAT communications cable.		Take noise countermeasures so that the noise does not affect the EtherCAT communications cable.
Attached information	None				
Precautions/Remarks	AL status code: -, Error No.: B200 hex				

*1. You can change the level to minor fault by using Warning Level Change 3 Selection (4020-07 hex).

Event name	Unit Restarted		Event code	90A00000 hex	
Description	Restart was performed.				
Source	EtherCAT Master Function Module	Source details	Slave	Detection timing	Operation by user
Error attributes	Level	Information	Recovery	---	Log category System log
Effects	User program	Continues.	Operation	Not affected.	
Indicators	EtherCAT NET RUN		EtherCAT NET ERR		EtherCAT LINK/ACT
	---		---		---
System -defined variables	Variable		Data type		Name
	None		None		None
Cause and correction	Assumed cause		Correction		Prevention
	Restart was performed		---		---
Attached information	None				
Precautions/Remarks	AL status code: 8000 hex, Error No.: -				

Event name	STO Detected		Event code	9821 0000 hex	
Description	The safety input OFF state was detected via the safety input signal or EtherCAT communications.				
Source	EtherCAT Master Function Module		Source details	Slave	Detection timing Continuously
Error attributes	Level	Information ^{*1}	Recovery	---	Log category System log
Effects	User program	Continues.	Operation	Power drive circuit is OFF	
Indicators	EtherCAT NET RUN		EtherCAT NET ERR		EtherCAT LINK/ACT
	---		---		---
System-defined variables	Variable		Data type		Name
	None		None		None
Cause and correction	Assumed cause		Correction		Prevention
	The cable is disconnected or broken		Reconnect the input wiring for safety inputs 1 and 2. If the cable is broken, replace it.		Connect the input wiring for safety inputs 1 and 2 securely.
		The STO input was turned OFF via EtherCAT communications		Remove the cause that turned OFF the safety input signal of the Safety Input Unit.	Improve the surrounding environment based on the cause that turned OFF the safety input signal of the Safety Input Unit.
Attached information	None				
Precautions/Remarks	AL status code: -, Error No.: C000 hex				

*1. You can change the level to minor fault by using Information Level Change Selection (4030-01 hex).

Event name	Memory All Cleared		Event code	9822 0000 hex	
Meaning	The Unit setting was cleared.				
Source	EtherCAT Master Function Module		Source details	Slave	Detection timing Operation by user
Error attributes	Level	Information	Recovery	---	Log category System log
Effects	User program	Continues.	Operation	Not affected.	
Indicators	EtherCAT NET RUN		EtherCAT NET ERR		EtherCAT LINK/ACT
	---		---		---
System-defined variables	Variable		Data type		Name
	None		None		None
Cause and correction	Assumed cause		Correction		Prevention
	Clear All Memory was performed		---		---
Attached information	None				
Precautions/Remarks	AL status code: -, Error No.: -				

Event name	Event Log Cleared		Event code	9824 0000 hex	
Meaning	The event log was cleared.				
Source	EtherCAT Master Function Module	Source details	Slave	Detection timing	Operation by user
Error attributes	Level	Information	Recovery	---	Log category
Effects	User program	Continues.	Operation	Not affected.	
Indicators	EtherCAT NET RUN		EtherCAT NET ERR		EtherCAT LINK/ACT
	---		---		---
System -defined variables	Variable		Data type		Name
	None		None		None
Cause and correction	Assumed cause		Correction		Prevention
	Clear Event Log was performed		---		---
Attached information	None				
Precautions/Remarks	AL status code: -, Error No.: -				

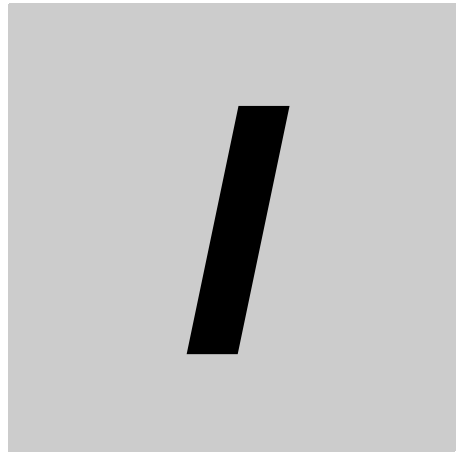

Index



Index

Numerics

7-segment LED Display 6-5

A

Absolute encoder 2-4
 Accessories 23
 AL Status Code List 7-35

C

Checking the Error Occurrence 7-2
 Control Circuit Connector (CND) 3-5

E

Encoder 3-11
 Encoder Connector (CN2) 3-8
 Error List 7-10, 7-14, A-2
 Event code A-2

I

Information 7-13

L

LED 6-5

M

Main Circuit Connector (CNA) 3-4
 Main Circuit Connector A (CNA) 3-5
 Main Circuit Connector B (CNB) 3-5
 Motor Connector (CNC) 3-4, 3-6

S

Servo Drive
 Characteristics 3-2
 How to Read Model Numbers 2-4
 Replacing 7-4
 Servo Drive and Servomotor Combination Tables 2-6
 Servomotor
 Characteristics 3-12
 General Specifications 3-10
 Installation Conditions 4-2
 Model Tables 2-5
 Replacing 7-4
 Servo Drive and Servomotor Combination Tables 2-6
 Servomotor model number 2-4
 Sysmac Studio 1-2, 2-2, 6-8

W

Warning List 7-8

OMRON Corporation Industrial Automation Company
Kyoto, JAPAN

Contact: www.ia.omron.com

Regional Headquarters

OMRON EUROPE B.V.

Wegalaan 67-69, 2132 JD Hoofddorp
The Netherlands
Tel: (31)2356-81-300/Fax: (31)2356-81-388

OMRON ELECTRONICS LLC

2895 Greenspoint Parkway, Suite 200
Hoffman Estates, IL 60169 U.S.A.
Tel: (1) 847-843-7900/Fax: (1) 847-843-7787

OMRON ASIA PACIFIC PTE. LTD.

No. 438A Alexandra Road # 05-05/08 (Lobby 2),
Alexandra Technopark,
Singapore 119967
Tel: (65) 6835-3011/Fax: (65) 6835-2711

OMRON (CHINA) CO., LTD.

Room 2211, Bank of China Tower,
200 Yin Cheng Zhong Road,
PuDong New Area, Shanghai, 200120, China
Tel: (86) 21-5037-2222/Fax: (86) 21-5037-2200

Authorized Distributor:

© OMRON Corporation 2016-2018 All Rights Reserved.
In the interest of product improvement,
specifications are subject to change without notice.

Cat. No. I619-E1-01

0418