

**F3SP-U4P-TGR**

**Safety Control Unit  
Safety Level 4**

**USER'S MANUAL**

**OMRON**

# **F3SP-U4P-TGR**

Safety control units,  
Type 4,  
For use with 1 or 2 pairs of safety light  
curtains

## **USER'S MANUAL**

---





The device conforms with the EC requirements in compliance with the following standards:

- Low Voltage Directive 73/23/EEC
- EMC Directive 89/336/EEC
- Machinery Directive 98/37/EC
- IEC 61496-1: 1997
- IEC 61496-2 ed.2 IEC 2001 (CDV draft 8)
- DIN V VDE 0801: 1990 and
- amendement A1: 1994
- EN 61000-4-2,-3,-4,-5,-6
- EN 55022: 1994
- DIN EN 60204-1: 1993
- EN 50178: 1997

MANUFACTURER:

TECHNO-GR s.r.l.  
via Torino, 13/15  
10046 Poirino (TO) - ITALY  
Tel. +39 011 9452041  
FAX +39 011 9452090

Version 3.0 date 12/06/03

## INDEX

<b>1</b>	<b>BEFORE USING THE DEVICE.....</b>	<b>5</b>
1.1	GENERAL INSTRUCTIONS.....	5
1.2	ROUTINE MAINTENANCE.....	5
1.3	PRECAUTION OF SAFETY.....	5
<b>2</b>	<b>GENERAL INFORMATION.....</b>	<b>6</b>
<b>3</b>	<b>OPERATION.....</b>	<b>8</b>
<b>4</b>	<b>PRECAUTIONS AND INSTALLATION CRITERIA.....</b>	<b>9</b>
4.1	CALCULATION OF THE MINIMUM INSTALLATION DISTANCE.....	9
<b>5</b>	<b>CONNECTIONS.....</b>	<b>10</b>
5.1	TERMINAL BLOCK ASSIGNMENT.....	10
5.2	PINOUT TOP VIEW.....	11
5.3	WIRING EXAMPLE.....	12
<b>6</b>	<b>ALIGNMENT PROCEDURE.....</b>	<b>16</b>
<b>7</b>	<b>OPERATING PROCEDURES.....</b>	<b>17</b>
7.1	DIP-SWITCHES CONFIGURATION.....	17
7.2	MUTING FUNCTION.....	18
7.2.1	DESCRIPTION.....	18
7.2.2	INSTALLATION CRITERIA.....	18
7.3	OVERRIDE.....	22
7.4	STARTING THE OVERRIDE FUNCTION.....	22
7.5	MUTING RESTRICTIONS (MUTING FUNCTION).....	23
<b>8</b>	<b>LED DIAGNOSTIC.....</b>	<b>24</b>
<b>9</b>	<b>FINAL CHECKS.....</b>	<b>25</b>
<b>10</b>	<b>ROUTINE MAINTENANCE.....</b>	<b>25</b>
<b>11</b>	<b>GENERAL INFORMATION AND USEFUL DATA.....</b>	<b>26</b>
11.1	OMRON LIGHT CURTAINS TO BE USED WITH THE F3SP-U4P-TGR.....	26
<b>12</b>	<b>TECHNICAL DATA.....</b>	<b>27</b>
<b>13</b>	<b>OVERALL DIMENSIONS.....</b>	<b>28</b>

# 1 BEFORE USING THE DEVICE.

## 1.1 GENERAL INSTRUCTIONS

Read this manual and the safety light curtain(s) (SLC) manual carefully and completely. Make sure the user information provided is understood before attempting to operate the light curtain.

Keep the manual in a secure and convenient location and confirm information if necessary.

To guarantee correct installation, carefully follow the instructions of this manual.

- Do not touch non-insulated cables, unless they have been disconnected from the power supply.
- Make sure that the cables connected to the control unit are not taut and that they do not hinder the movement of persons or objects.
- The control unit does not contain parts subject to maintenance. Do not open the control unit for any reason, and in case of failure, send it to our laboratories, indicating the fault and the operation period.
- A qualified person, as determined by local regulations, must confirm that installation, inspection, and maintenance have been implemented correctly.

**Failure to do so may result in lethal or serious injury.**

## 1.2 ROUTINE MAINTENANCE.

Please refer to sec. 10 and the safety light curtain instruction manual.

OMRON Europe and TECHNO-GR refuses to accept any responsibility for damage to persons or objects due to the incorrect use / installation of the device.

## 1.3 PRECAUTION OF SAFETY

The following symbols are used for highlighting items in order to ensure safe and proper use of the F3SP-U4P-TGR. Highlighted items are critical for safe operation and must be heeded at all times.



**NOTICE**



**WARNING**

## 2 GENERAL INFORMATION

**The safety control unit F3SP-U4P-TGR has been designed to be used with the dedicated light curtains. (Please refer to sec.11) It cannot be connected to other light curtains.**

The system conforms with the requirements for safety devices of type 4 in compliance with the international standards stated e.g. IEC 61496-1.

However, the safety system category depends on the light curtain's type as follows:

Type 4 light curtain : Safety system category 4 (EN954-1)

Type 2 light curtain : Safety system category 2 (EN954-1)

This safety device is made up of a control unit protected by a plastic housing so that it can be installed on a DIN/OMEGA rail; it has 32 removable screw terminals to which it is possible to connect from 1 to 2 pairs of light curtains.

This control unit has the double 'muting' function. This function makes it possible to obtain a "temporarily automatic suspension" of one or both safety light curtains in order to allow, for instance, the objects passage without stopping the machine.

The '*override*' function enables system, to keep the output relays closed even with intruded rays to enable material transport after a system shutdown.

Both *muting* and *override* functions represent a system that require additional precautions to limit the reduction of the safety level. This precautions have to be considered carefully.

The *muting and override* function is available by simply connecting the F39-A11 muting lamp (or similar yellow bulb type lamp for 24VDC / 3W to 5W) supplied separately.

The presence of a limb or an object interrupting a beam causes the opening of the safety outputs and the consequent stopping of the connected machine. It is necessary for the safety sensors to be connected in the right position in such a way that there isn't any possibility to climb over or defeat the system. Do not install the control unit in the corrosive, flammable or explosive gas. Do not use the cellular phone or transceivers near the control unit.

The unit has been designed in accordance to the following standards:

- IEC 61496-1: 1997. Safety of machinery: electro-sensitive protective devices
  - General requirements and test.
- FDIS IEC 61496-2: 1997. Safety of machinery: electro-sensitive protective devices
  - Particular requirements for system using active opto-electronic devices.



### 3 OPERATION.

The electronic control system of the device is made up of a microprocessor. By means of the suitable hardware, it continuously control and check the connected photocells. No interference among the safety sensors is possible as they are controlled sequentially; it will be thus possible to install one or two adjacent safety sensors. When one or more beams are interrupted, the electronic system opens the outputs.

The SLC have been triggered are displayed by LEDs on the housing.

The control-unit can work in two different modes (please refer to par. 7 page 17) which he can carry out the following operations:

The two external buttons that have to be connected are for:

- TEST : This is used to check if the whole system works effectively. By pressing the TEST button (opening of the contact), this simulates the interruption of one or more safety sensors. This operation makes the machine stop, so the system checks can be made according to the established time and modes. If pressed after a failure detection of the unit (see the table error code), reset of the system is required.
- RESET button: It is used to start the system, also for manual reset condition after relay triggering or after an error which can be reset (see table related to the error codes).

Two different operating modes are available:

1. Automatic reset: The system will start automatically after the beam intrusion have been removed.
2. Manual reset: The system will remain in safe off condition until the RESET button have been pressed. This manual reset allows to start the system only on a wanted action of the user.

**During the unit working, no operation set by the user interface involves functions which can influence the system safety.**

## 4 PRECAUTIONS AND INSTALLATION CRITERIA.

The safety products used must be suitable for the required application, other influences must also be taken into account such as room temperature, electromagnetic interference, intense light sources etc. Please refer to the manual for specification or contact the manufacturer for details.

### 4.1 CALCULATION OF THE MINIMUM INSTALLATION DISTANCE.

The safety distance 'S' must be sufficient to guarantee that the hazardous area cannot be reached by the operator up to the moment in which the hazardous movement stops. Please refer to EN999 or corresponding C-standards and the safety light curtain's instruction manual;

The EN 999 uses this general formula



$$S = (K \times T) + C$$

S = safety distance.

T = T1 + T2 + T3

whereas T1 = machine response time in seconds.

T2 = light curtains response time in seconds.

T3 = controller response time in seconds.

K = speed of the body approaching the hazardous area.

C = additional distance calculated or defined based on the optical resolution of the light curtain.

## 5 CONNECTIONS.

### 5.1 TERMINAL BLOCK ASSIGNMENT.

TERMINAL	OUTER CONNECTION
1 - 2	Connect to the 24 VDC power supply, note the polarity indicated on the label.
3 - 4	RESET button; connect a normally opened contact (N.O.).
4 - 5	TEST button; connect a normally closed (N.C.).
6 - 7	Connect the muting lamp.
8	Input of the muting <b>A</b> sensor. Connect to the N.O. contact of the muting sensor (photozell, proximity switch, other).
9	Input of the muting <b>B</b> sensor. Connect to the N.O. contact of the muting sensor (photozell, proximity switch, other).
10	Input of the muting <b>D</b> sensor. Connect to the N.O. contact of the muting sensor (photozell, proximity switch, others)
11	Input of the muting <b>C</b> sensor. Connect to the N.O. contact of the muting sensor (photozell, proximity switch, others)
12	Earth. Connect to the plant's earth
13 - 14	(OUT1) safety output 1 with N.O. contact.
15 - 16	(OUT2) safety output 2 with N.O. contact.
17 - 18	Power supply transmitters (TX1) for light curtain 1. 24VDC wire to terminal 17, 0V wire to terminal 18.
19 - 20	Terminal not used.
21 - 22	Power supply transmitters (TX2) for light curtain 2. 24VDC wire to terminal 21, 0V wire to terminal 22.
23 - 24	Terminal not used.
25 - 26	Power supply receivers (RX1) for light curtain 1. 24VDC wire to terminal 25, 0V wire to terminal 26.
27 - 28	Connect to the PNP output of the receivers (RX1) of light curtain Control output 1 wire and Control output 2 wire to terminal 27 and 28. (Two control outputs must be used.) No use of light curtain 1. (Use of only light curtain 2) It shall be connected the terminal 27 and 28 to terminal 25.
29 - 30	Power supply receivers (RX2) for light curtain 2. 24VDC wire to terminal 29, 0V wire to terminal 30
31 - 32	Connect to the PNP output of the receivers (RX2) of light curtain 2 Control output 1 wire and Control output 2 wire to terminal 31 and 32. (Two control outputs must be used.) No use of light curtain 2. (Use of only light curtain 1) It shall be connected the terminal 31 and 32 to terminal 29.

5.2 PINOUT TOP VIEW

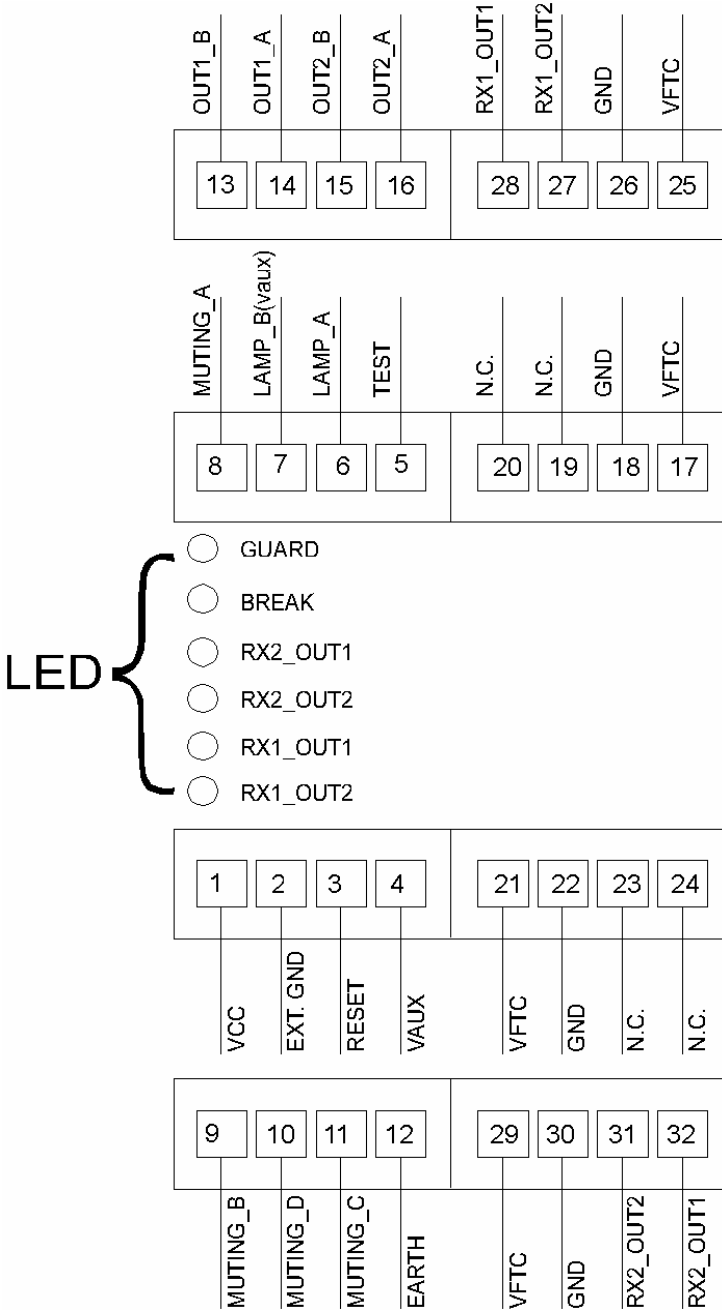

### 5.3 WIRING EXAMPLE.

Connection of two F3SN light curtains to the control unit F3SP-U4P-TGR.

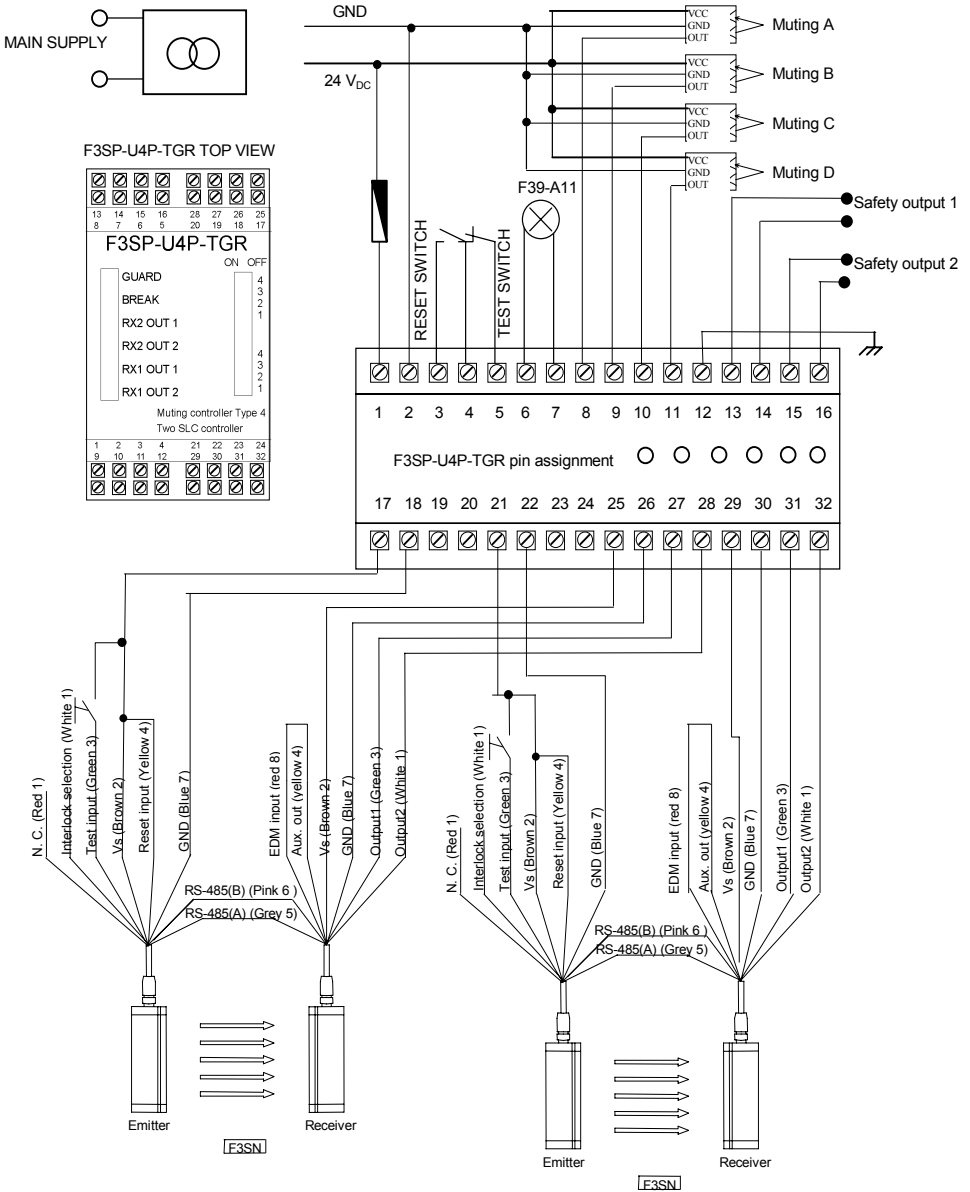



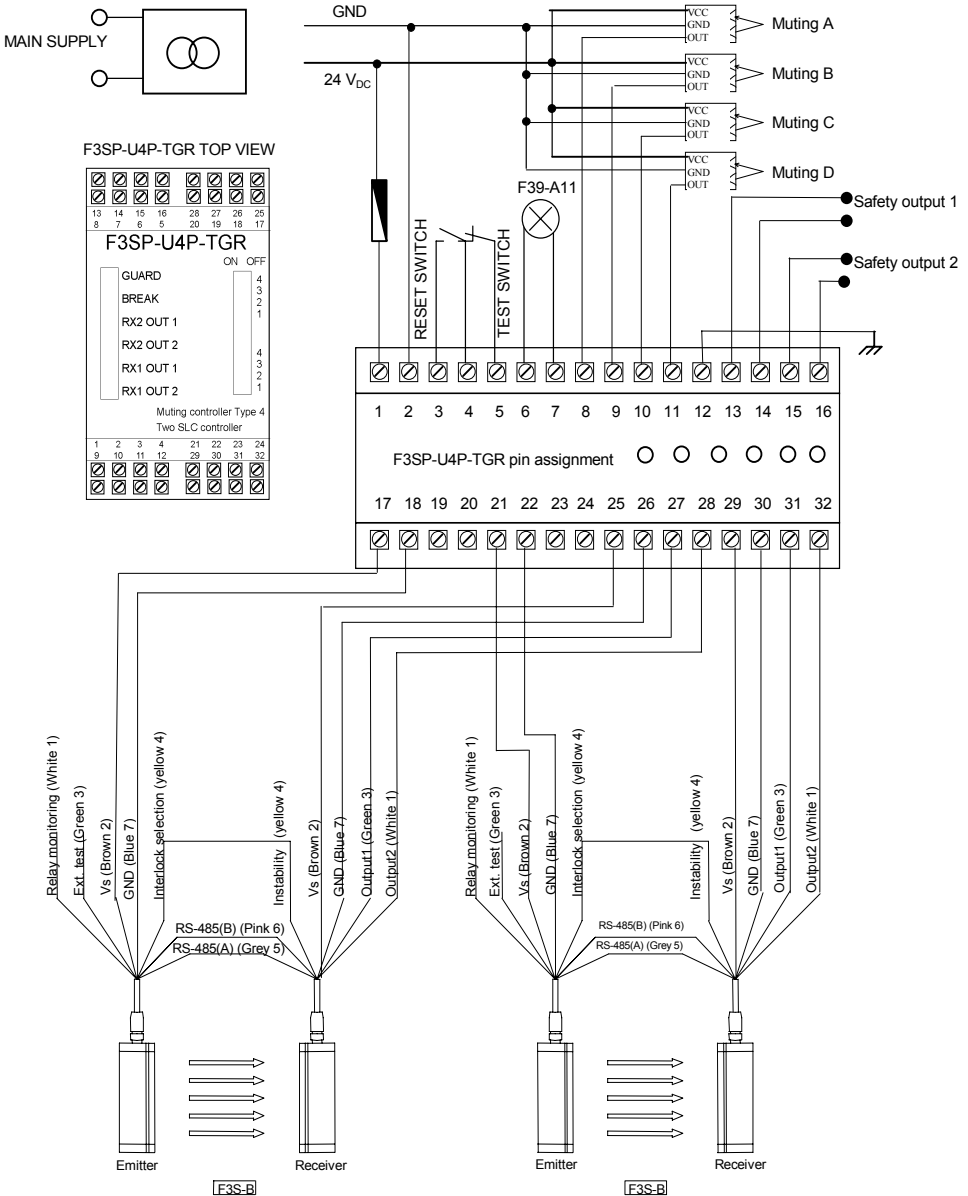

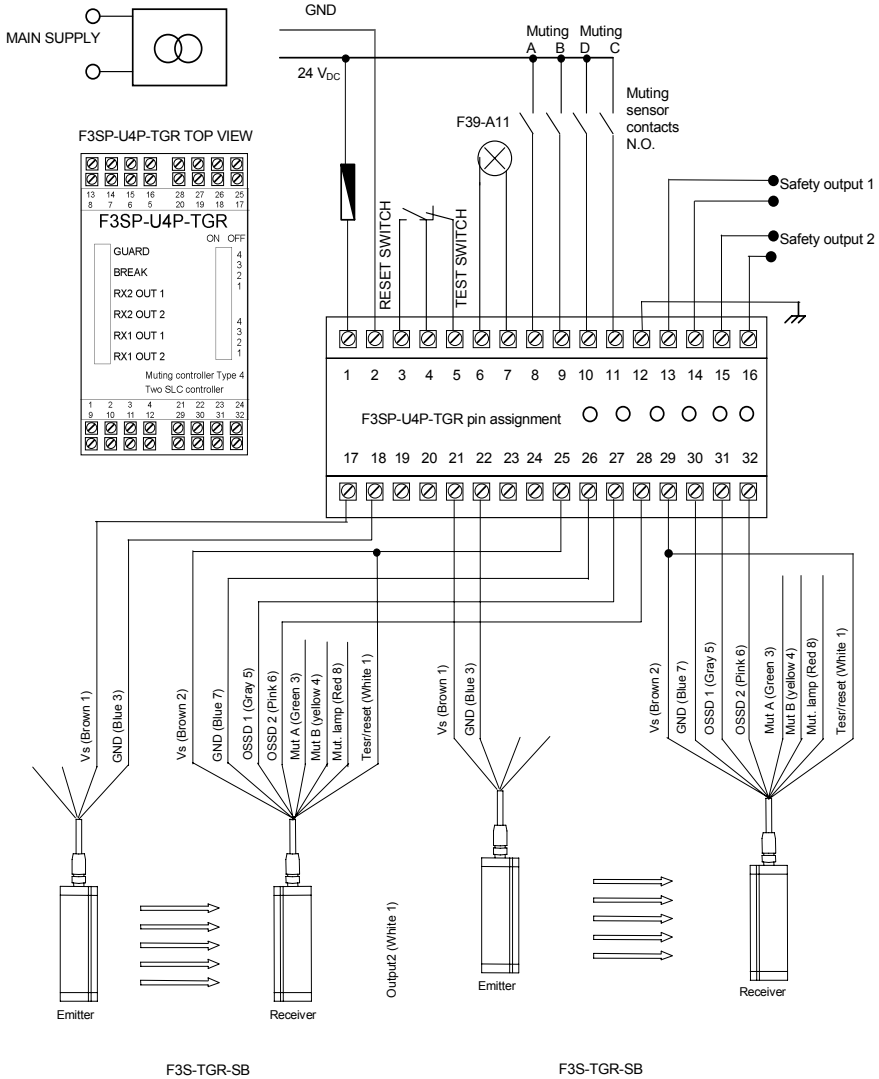

Connection of two F3S-B light curtains to the control unit F3SP-U4P-TGR.



Connection of two F3S-TGR-SBx-Kx-xxx light curtains to the control unit F3SP-U4P-TGR.



## Notice

- To configure the control unit in such a way that it works with one single safety light curtain, it is necessary to connect the terminal 31 and 32 to the terminal 29.
- 
  - DC power supply units must satisfy all the conditions below in order to conform to the application directives.
    - 1) The power supply voltage should be within rating (24VDC +/- 10%)
    - 2) The power supply conforms to EMC Directive (industrial environment) and LOW-Voltage Directive.
    - 3) The power supply uses double insulation between the primary and secondary circuits.
    - 4) The power supply should include over current protection limited up to 4 A.
    - 5) The power supply maintains an output holding time of at least 20ms.
  - 
    - The power supply which is necessary to power the system must conform to standard EN 60742 (double insulation) or with equal insulation, for instance VDE 0551.
  - 
    - It is necessary to protect the control unit with an outer fuse having a nominal interruption current equal to 1 A.
  - 
    - The TEST and RESET buttons must be positioned in such a way that the operator can see the protected area when he restarts, or carries out a test or override operation.
  - 
    - The muting lamp (F39-A11) must be positioned in a place where it can be seen from any operative point.
  - 
    - Read the paragraph relating to the muting function and its use for the positioning of the activation sensors of this function.
  - 
    - Both safety contacts OUT1 and OUT2 must be connected. If the machine has a single locking circuit, the two normally opened contacts must be connected in series.
  - The connection cables of the light curtains, of muting request, test and reset must be masked with minimum section 22AWG. The cable shield braids must be all earthed on the control unit side.
  - Be sure to isolate the power prior to wiring.



## 6 ALIGNMENT PROCEDURE.

After having carried out the correct mechanical assembly and the correct connections as described in the previous paragraphs, it is necessary to align the light curtains. Follow the operating guide as follows:

- Turn off the power supplying the control unit.
- Open the test contact.
- Power the control unit.
- Align the light curtain by observing the LEDs on the control unit: If the alignment of the light curtain 1 is correct, the LED 1 and 2 are turned on. If the alignment of the light curtain 2 is correct, the LED 3 and 4 are turned on.
- After the alignment, turn off the power supplying the control unit, close the test contact and power the control unit again.
- Wait for the control unit to carry out the initial tests.
- At the end of this operation, the unit indicates the right alignment with the guard led green on.
- Carry out all the checks described in the final checks and in the routine maintenance operations.

During aligning operations or normal working, check that the light curtains connected to the same or other units do not interfere with each other. Modifying their mutual position for instance by positioning emitter on the other receiver side.

## 7 OPERATING PROCEDURES.

### 7.1 DIP-SWITCHES CONFIGURATION.

The configuration indicated in the table must be selected on both the *dip-switches* available in the front cover.

4	Function
X	not used

3	Function
Off	muting A-B act on the light curtain 1. muting C-D act on the light curtain 2.
On	Forbidden

2	Function
Off	muting 60 s
On	muting $\infty$ s *



1	function
Off	interlock mode
On	automatic mode

- The control-unit is Factory default set with the following configuration: Automatic reset, the maximum duration of the muting: sixty seconds.

\* Infinite muting duration: this feature must be used carefully because it's against the norm. Using this, the user must know that it's works under it's sole responsibility.

## 7.2 MUTING FUNCTION.

### 7.2.1 DESCRIPTION.

The muting function makes it possible to obtain a “temporarily automatic suspension” of one or both light curtains in order to allow, for instance, the objects passage without stopping the machine. As required by the standard, the control unit has two inputs for the activation of this function. Two separate muting functions are possible to use.

It is necessary to position and connect the muting sensors in order to avoid void muting input condition. It is important to remember that the muting function forces the system keep working and for this reason the muting functionality must be designed and handled with care.



To use the muting function, it is mandatory to have the F39-A11 muting lamp connected to the control unit, otherwise the control unit is locked.

### 7.2.2 INSTALLATION CRITERIA

- 1 The muting sensors must recognise the material (pallets, vehicles, etc.) over its full length.
- 2 The sensors must be arranged in such a way that the material is recognised even when it is on a pallet or other transporting medium.
- 3 In case of different transport speeds through the muting area, consideration must be used on the muting duration.
- 4 All the light curtains and the muting sensors must be arranged in such a way that the previous material has already passed the last muting sensor before the new material has reached the first muting sensors.

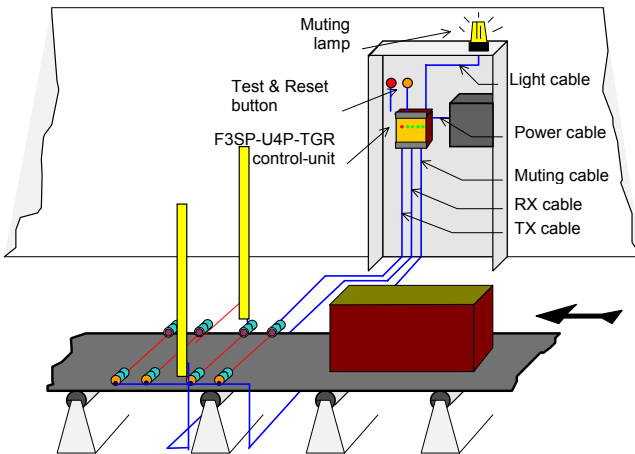

**Application with four muting sensors:**

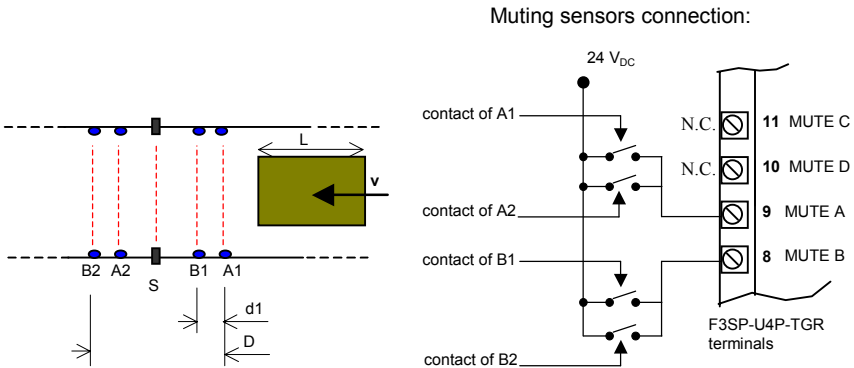

**Application with two muting sensors:**

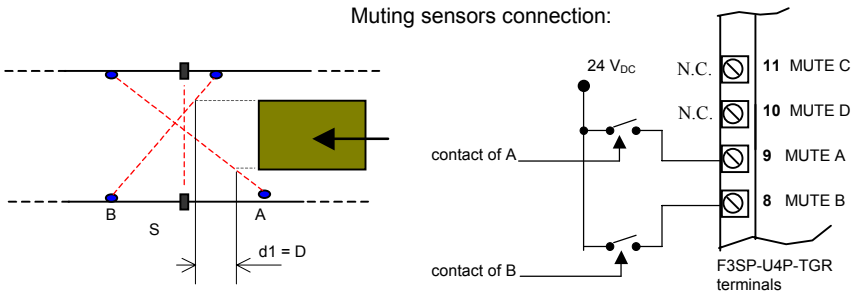

**D:** minimum distance so that the muting sensors keep active the request; it depends on the parcel length:  $D < L$ .

**d<sub>1</sub>:** necessary maximum distance so that the muting request is accepted; it depends on object speed:

$$d_{\max} [\text{cm}] = v [\text{m/s}] \times 3 [\text{s}] \times 100$$





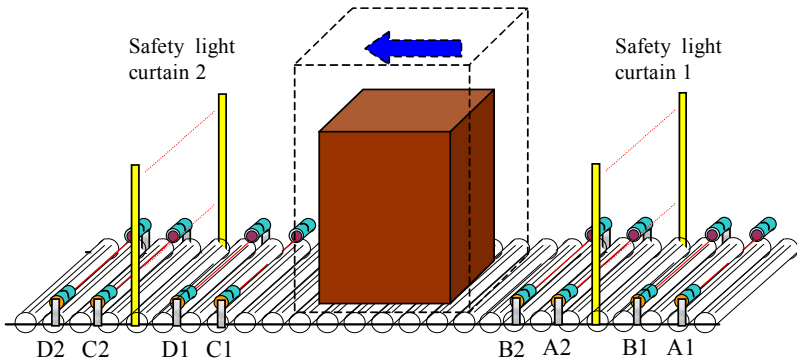

This distance must not allow both sensors and the muting cycle with the passage of a person.

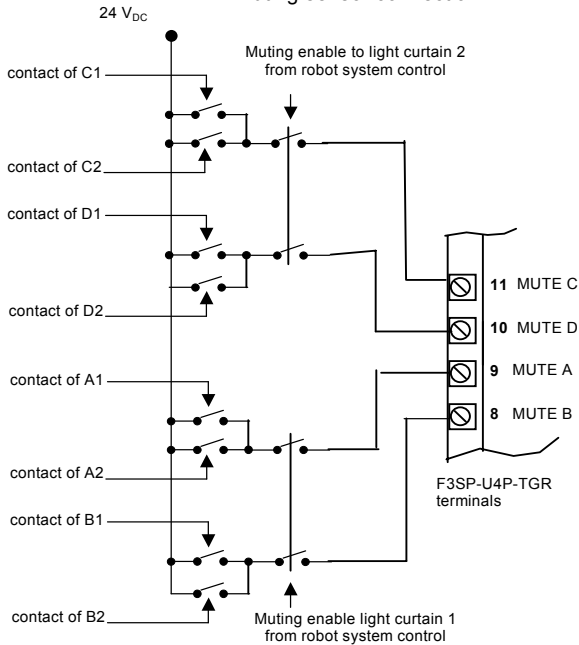
Application with eight muting sensors for output and input control



Muting sensor connection:



-  • The TEST and RESET buttons must be positioned in such a way,
  - that the operator can see the protected area when he carries out reset, test or override operations.
  - that it can not be activated from inside the hazardous area.
-  • The F39-A11 *muting* lamp for indication “active muting” must be positioned in a place where it can be seen from any operative point.
-  • If the muting sensors are installed close to the light curtains, it is necessary to install the sensor receivers near the light curtain emitter side to avoid interference.
-  • The system is protected from possible failures due to the cable damage; it is necessary to prepare the wiring to avoid damage to the connection cables.
-  • The control unit must be located in a cabinet with protection degree of at least IP54.
-  • Muting sensors must be positioned so that they cannot be activated inadvertently by personnel.
-  • The control unit does not have power supply terminals for muting sensors.

### **7.3 OVERRIDE.**

This function makes it possible to force a muting condition, if necessary by starting the machine despite one or both safety light curtains having been interrupted by the object. Thus enabling removal of the material from the protected area, when it has been stuck in the beam of the safety light curtains due to a failure.

Suppose that a pallet has stopped before the light curtains; the conveyor belt cannot be started again because the control unit - after having detected one or more interrupted light curtains- will not close the safety outputs, thus making it impossible to free the controlled area.

By starting the override function, it will be possible to carry out this operation.

### **7.4 STARTING THE OVERRIDE FUNCTION.**

- Switch off the control unit.
- Make sure that the TEST and RESET buttons are connected. (N.C. for the TEST button, N.O. for the RESET button).
- Switch on the control unit.
- Within 10 seconds, press together the test and reset buttons and keep pressing. (At each switching on operation, a test is carried out to check that the buttons are not locked).
- The override function has been activated. The muting lamp blinks to signal the light curtain disconnection.
- The maximum duration of the override function amounts to 60 seconds after that the light curtain is connected again even if the buttons are pressed. If the buttons are released before this time has elapsed, the override function will be immediately stopped.

## 7.5 MUTING RESTRICTIONS (muting function).

- The muting operation must occur according to the correct timing sequence. For the two muting channels, it is necessary to activate input MUTE\_A or MUTE\_C at first and then input MUTE\_B or MUTE\_D within 3 seconds. If not, the muting sequence will not be activated.
- When the muting state is active, an object can remain for a period of no longer than 60 s., otherwise the muting function is switched off. This mechanism is optional and can be deactivated when the control unit is set up. (see page 17)
- For the cases in which the muting function is automatically disabled because of time-out, the request must be cut-out (override function, or removing object (and restart)) to generate the following correct muting state.

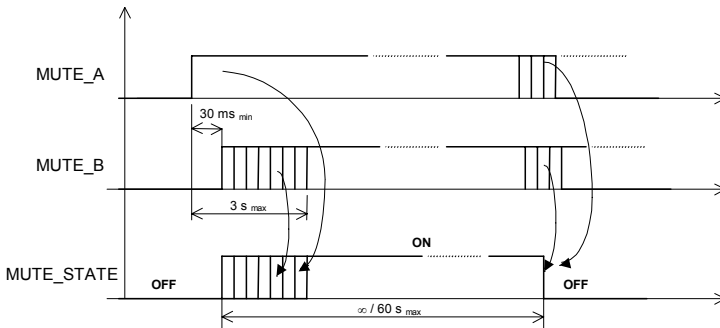

It is not possible to carry out a muting request, if the light curtain is interrupted and the output contacts are in the opened state.



## 8 LED DIAGNOSTIC

Information of the units operative state by means of six LEDs.

The LED state has the following meaning:

- LED1: GREEN LEDs: if switched on, the photocells work regularly and no object is detected; the relays are closed.
- LED2: RED LED: if switched on, the unit has detected an object or an error has occurred – which can be possibly recovered by pressing the reset button-; in this condition, the safety outputs are opened.
- LED 3-6: GREEN “LED RX OUT”: if switched on, the barrier is working regularly and there are no detected obstacles; in this condition, the safety outputs are closed

The Unit include a simple diagnostic indications on the most significant errors.

- One LED flashing.  
Error in an Safety light curtain.
- Two LED flashing.  
Error in connection of bypassed SLC.
- Three LED flashing.  
Error in muting lamp or invalid sequence of muting.
- Four LED flashing.  
Internal fail of system.

All these errors are resettled by the TEST pushbutton, if the error condition is false.

THE LED INDICATIONS CAN BE POSSIBLE ONLY IF THE SLC ASSOCIATED TO THE LED FLASHING ARE FREE. IF THE SLC ARE INTERRUPTED THE LEDS CAN ONLY BE OFF.

## 9 FINAL CHECKS.



Check that the area protected by the safety light curtain is free from any obstacle; check the correct triggering of the output contacts opening by interrupting the protection rays (red LED switched on, controlled machine stopped).



**CAUTION!** If the red LED switches on and off, check the correct mechanical installation.



**NOTE.** *This check must be repeated each time you move or mechanically re-align the safety light curtains and muting sensors.*

## 10 ROUTINE MAINTENANCE.

Be sure to conduct inspection checks as below regularly.

- Check that there is no person in the hazardous area before operator turns ON the power.
- Check that the unit locks by inserting a moving object through the detection zone.
- By opening the test contact, check that the output contacts are opened (red LED switched on and machine stopped).
- Make sure that the access to the hazardous areas is not possible from any non-protected area and that the minimum distance from the safety light curtain to the hazardous part is not less than the result calculated with reference to the formula reported at paragraph 4.1.
- Make sure the installation satisfies one of following conditions;
  - 1) The machine connected to the control unit has an interlock function.
  - 2) The controller uses interlock mode.
  - 3) It is not possible for a person to stop between the safety light curtain and the hazardous parts of the machine.
- Make sure that there is no outer damage to the safety light curtain and/or the outer electrical connections.
- Make sure that the response time, including the safety light curtain and the machines, does not exceed the established limits.
- If failure occurs, all functions of the control unit shall be tested.

The frequency of these operations depends on the special applications and operative conditions.

## 11 GENERAL INFORMATION AND USEFUL DATA.

 Safety **MUST** be part of our consciousness.  
The safety devices are only effective if installed correctly by respecting the guidelines laid down in the relevant standards.  
These devices should be installed by a competent person. Please contact our office for advise on service or installation.

Problems due to voltage interruption on the power supply may cause temporary openings of the outputs. This is not damaging to the safety PES and control unit.

The guarantee is complete for a period of 12 months starting from the delivery date of the device.

Defects which are clearly due to damage caused by an incorrect use, accidental causes or catastrophic events are not covered by the guarantee.

In case of failure, send the unit indicating the detected failure and the operational period to:

 TECHNO-GR via Torino, 13/15  
10046 Poirino (TO) - ITALY  
Tel. +39 011 9452041  
FAX. +39 011 9452090

### 11.1 OMRON LIGHT CURTAINS TO BE USED WITH THE F3SP-U4P-TGR

- F3SN range
- F3SH range
- F3SL range
- F3SS range
- F3S-B range
- F3S-TGR-SB2- range
- F3S-TGR-SB4- range

## 12 TECHNICAL DATA.

- The control unit can be used with all safety light curtains listed 11.1  
Note that all safety light curtains to be used are certified according with the EN61496-1 Type 4/ Type 2
- Electrical input: 420 mA max. (for any model).
- Voltage: 24 Vdc  $\pm$  10%.
- Number of light curtains: 2 pairs max.
- Indicators: 5 green LEDs, 1 red LED.
- Response time:  $\leq$  18 ms
- Working temperature: -10 a + 55 °C.
- Humidity: from 15% to 95% (not condensing).
- Output contacts: 2 NO, 2.5 A max, 250 Vac,  $\cos\phi$  0.6  $\div$  1
- Switch capability: 1,500 VA, 180W
- Electrical life expectance: 100.000 op. minimun at 1,800 oprs/hr.
- Outer controls: test, reset, muting and override.
- Housing: plastic case for installation on a din/omega rail
- Protection class of control unit: IP 20.
- Protection class of the cabinet containing the control-unit: IP54 at least.
- Weight: control unit 600 g.
- Features of fuses muting lamp: internal resettable fuse 315mA T 250V.
- Muting lamp: F39-A11 incandescent lamp 24 V, 3 W min, 300 mA max.

### 13 OVERALL DIMENSIONS.

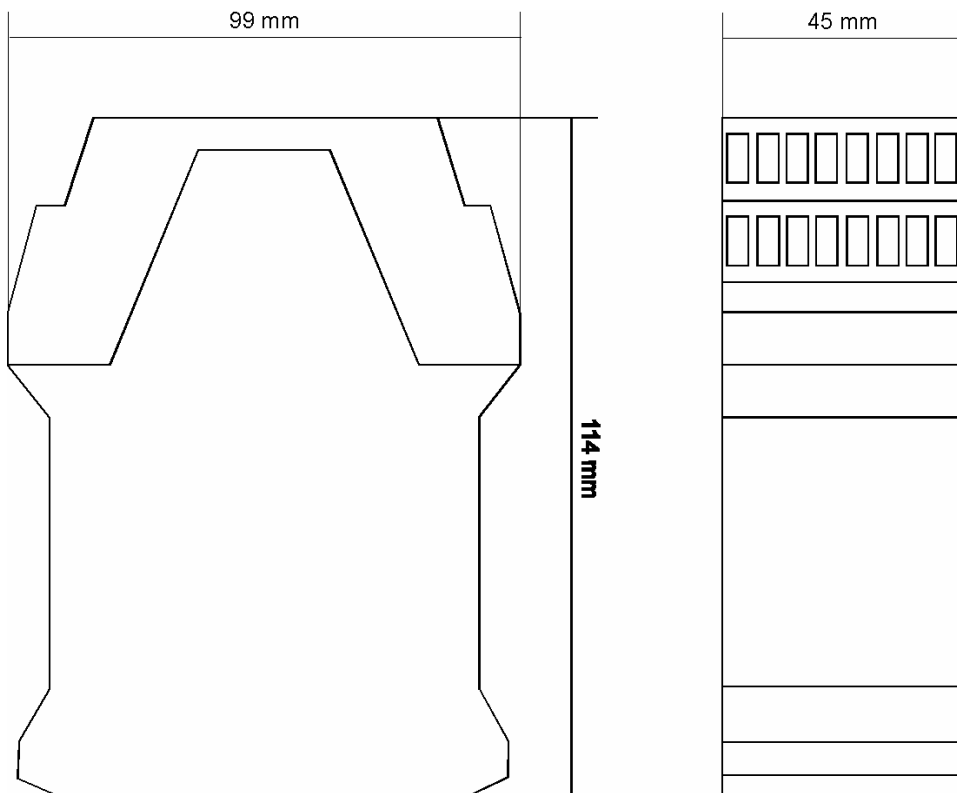

Control unit  
**F3SP-U4P-TGR**



**MANUFACTURER**



**TECHNO-GR s.r.l.**

via Torino, 13/15  
10046 Poirino (TO)  
ITALY  
Tel: +39-011-9452041 / FAX: +39-011-9452090

**GENERAL AGENCY**

**OMRON EUROPE B.V.  
SENSOR BUSINESS UNIT**

Carl-Benz-Str.4  
71154 Nufringen  
GERMANY  
Tel: +49-7032-811-0 / Fax: +49-7032-811-199

**Authorised Distributor:**