

Interface Converter K3SC

CSM_K3SC_DS_E_5_1

A compact converter that allows communications between RS-232C/USB and RS-422/485 devices. Ideal for industrial applications.

- Allows communications between RS-232C/USB (Universal Serial Bus) and RS-422/485 devices.
- Applicable in FA environments: Has passed environment resistance tests equivalent to those for control devices.
- CE marking (except for USB).
- UL/CSA certification (mark license recognition).
- Compact 30-mm-wide body supports both screw-mounting and DIN track mounting.
- Operation either with or without echoback available.
- Functionality to convert between USB and RS-232C communications added.
- USB driver providing virtual communications port for USB communications is available.

Note: To use USB communications, the USB driver for the K3SC must be downloaded from the OMRON web site.

Application Examples

- Data can be transferred between computers (using the USB port if there is no RS-232C port) and field devices.
- Using two K3SC Units enables long-distance communications between devices connected via RS-232C.



Refer to *Safety Precautions* on page 8.

Ordering Information

■ List of Models

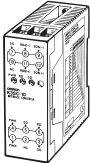
Appearance	Size (mm)	Power supply voltage	Model
	30 × 80 × 78 (W × H × D)	100 to 240 VAC	K3SC-10 100 to 240 VAC
		24 VAC/VDC	K3SC-10 24 VAC/VDC

■ Accessories (Order Separately)

Adapter for RS-232C Serial Cable and K3SC (D-Sub, 9-pin, male)

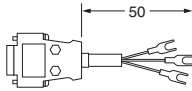
Appearance	Wiring diagram	Model																								
	<p>D-Sub, 9-pin</p> <table border="1"> <thead> <tr> <th>Pin</th> <th>Signal</th> <th>M3.5 terminals</th> </tr> </thead> <tbody> <tr> <td>3</td> <td>SD</td> <td>SD (orange)</td> </tr> <tr> <td>2</td> <td>RD</td> <td>RD (white)</td> </tr> <tr> <td>5</td> <td>SG</td> <td>SG (gray)</td> </tr> <tr> <td>7</td> <td>RS</td> <td></td> </tr> <tr> <td>8</td> <td>CS</td> <td></td> </tr> <tr> <td>6</td> <td>DR</td> <td></td> </tr> <tr> <td>4</td> <td>ER</td> <td></td> </tr> </tbody> </table>	Pin	Signal	M3.5 terminals	3	SD	SD (orange)	2	RD	RD (white)	5	SG	SG (gray)	7	RS		8	CS		6	DR		4	ER		K32-23209
Pin	Signal	M3.5 terminals																								
3	SD	SD (orange)																								
2	RD	RD (white)																								
5	SG	SG (gray)																								
7	RS																									
8	CS																									
6	DR																									
4	ER																									

Specifications

■ Ratings

Item	K3SC-10 100 to 240 VAC	K3SC-10 24 VAC/VDC								
Supply voltage	100 to 240 VAC 50/60 Hz	24 VAC 50/60 Hz, 24 VDC								
Operating voltage range	85% to 110% of power supply voltage									
Power consumption	5 VA max.	3 VA max./3 W max.								
Master/slave device communications format (Select one of the formats listed on the right using the DIP switch.)	<table border="0"> <tr> <td><u>Master Device</u></td> <td><u>Slave Device</u></td> </tr> <tr> <td>RS-232C or USB</td> <td>RS-485, half duplex</td> </tr> <tr> <td>RS-232C or USB</td> <td>RS-422, full duplex</td> </tr> <tr> <td>USB</td> <td>RS-232C, full duplex</td> </tr> </table>	<u>Master Device</u>	<u>Slave Device</u>	RS-232C or USB	RS-485, half duplex	RS-232C or USB	RS-422, full duplex	USB	RS-232C, full duplex	
<u>Master Device</u>	<u>Slave Device</u>									
RS-232C or USB	RS-485, half duplex									
RS-232C or USB	RS-422, full duplex									
USB	RS-232C, full duplex									
Communications method	Start-stop synchronization									
Ambient operating temperature	RS-232C	-10 to 55 °C (with no icing)								
	USB	0 to 55 °C (with no icing)								
Ambient operating humidity	25% to 85% (with no condensation)									
Ambient storage temperature	-20 to 65 °C									

■ Characteristics

Item			Specification
Master device	RS-232C interface (See note 1.)	Maximum transmission distance	15 m
		Maximum number of connectable Units	1 Unit
	USB interface (See note 2.)	Maximum transmission distance	5 m; hub delay time + cable delay time ≤ 70 ns
		Maximum number of connectable Units	1 Unit
	USB standard	V1.1	
Slave device	RS-485 interface	Maximum transmission distance	500 m
		Maximum number of connectable Units	31 Units (for multi-drop connection)
	RS-422 interface	Maximum transmission distance	500 m
		Maximum number of connectable Units	1 Unit
Baud rate			1,200/2,400/4,800/9,600/19,200/38,400 (bps) Default setting: 9,600
Data length			7/8 bits Default setting: 7
Stop bit length			1/2 bits Default setting: 2
Communications parity			None/even/odd Default setting: Even
Echoback selection			Echoback: With/without Default setting: Without
Selection switch response delay			Approx. 30 ms
Insulation resistance			20 MΩ min. measured at 500 VDC between the following: External terminals ↔ casing RS-232C terminals and USB port ↔ RS-422/485 terminals ↔ power supply terminals
	Isolation method	Communications	Phototransistor coupler
		Power supply	Isolating transformer
Dielectric strength			1,500 VAC for 1 minute measured between the following: External terminals ↔ casing RS-232C terminals, USB port, RS-422 terminals, and RS-485 terminals ↔ power supply terminals 500 VAC for 1 minute measured between the following: RS-232C terminals and USB port ↔ RS-422 terminals and RS-485 terminals
Noise immunity			AC power supply terminals, normal/common mode: ±1,500 V AC/DC power supply terminals, normal mode: ±480 V; common mode: ±1,500 V Square wave with 1-ns rising edge ±1 μs, ±100 ns
Vibration resistance	Malfunction	10 to 55 Hz, 0.5-mm single amplitude for 10 minutes each in X, Y, and Z directions	
	Destruction	10 to 55 Hz, 0.75-mm single amplitude for 2 hours each in X, Y, and Z directions	
Shock resistance	Malfunction	98 m/s ² 3 times each in X, Y, and Z directions	
	Destruction	294 m/s ² 3 times each in X, Y, and Z directions	
Weight			Approx. 150 g
Degree of protection (See note 3.)	Front panel operation parts	Conforms to IEC standards, equivalent to IP20 (when terminal cover mounted)	
	Terminals	Equivalent to VDE 0106/100 (when terminal cover mounted)	
EMC			(EMI) EN61326-1 Industrial electromagnetic environment Emission Enclosure: CISPR 11 Group 1 class A: CISRP16-1/-2 Emission AC Mains: CISPR 11 Group 1 class A: CISRP16-1/-2 (EMS) EN61326-1 Industrial electromagnetic environment Immunity ESD: EN61000-4-2: 4 kV contact discharge (level 2) 8 kV air discharge (level 3) Immunity RF-interference: EN61000-4-3: 10 V/m (amplitude-modulated, 80 MHz to 1 GHz) (level 3) Immunity Fast Transient Noise: EN61000-4-4: 2 kV (power line) (level 3) Immunity Burst Noise: 1 kV line to line (I/O signal line) Immunity Surge: EN61000-4-5: 1 kV line to line 2 kV line to ground (power line) Immunity Conducted Disturbance EN61000-4-6: 3 V (0.15 to 80 MHz) (level 2) Immunity Voltage Dip/Interrupting EN61000-4-11: 0.5 cycles, 0, 180°, 100% (rated voltage)
Approved standards			UL508, Conforms to EN61326-1, EN61010-1 (IEC61010-1)
Memory protection			No protective functions (Communications data is not protected for power interruptions during communications.)

- Note:**
1. With RS-232C communications, free-run mode is supported for SD and RD but not for any other signal lines.
 2. To use USB communications, the USB driver for the K3SC must be downloaded from the OMRON web site.
<http://www.fa.omron.co.jp/>
 3. The enclosure ratings do not apply when USB is used.
 4. The CE marking does not apply when the K3SC is used for USB.

Connections

Terminal Specifications

Be sure to check the input and output specifications for the signal pins of connected devices before connecting the terminals.

Function	Terminal number	Name	Signal direction	Explanation
For connecting the operating power supply	1 and 4	PWR	---	The input power supply specifications vary with the model. A 100 to 240-VAC model and a 24-VAC/VDC (no-polarity) model are available.
Connection terminals for RS-232C communications with master device (DIP switch pin 8: OFF)	3	SG	---	Connect to signal ground.
	5	SD	Input	Receives data from SD of the master device.
	6	RD	Output	Sends data to RD of the master device.
Used for RS-485 communications with slave device (DIP switch pin 9: OFF)	8	RDA(-)	Input/output	SD and RD for RS-485 (cold side) Terminals 8 and 9 are connected internally when pin 9 of the DIP switch is set to OFF.
	9	SDA(-)		
	11	RDB(+)	Input/output	SD and RD for RS-485 (hot side) Terminals 11 and 12 are connected internally when pin 9 of the DIP switch is set to OFF.
12	SDB(+)			
Used for RS-422 communications with slave device (DIP switch pin 9: ON)	7	SG	---	Connect to signal ground.
	8	RDA(-)	Input	Receives RS-422 data and outputs it to the master side.
	9	SDA(-)	Output	Converts data received via RS-232C from the master device to RS-422 data and outputs the data.
	11	RDB(+)	Input	Receives RS-422 data and outputs it to the master side.
	12	SDB(+)	Output	Converts data received via RS-232C from the master device to RS-422 data and outputs the data.

Note: Terminals 2 and 10 are not used.

Internal Configuration (Block Diagram)

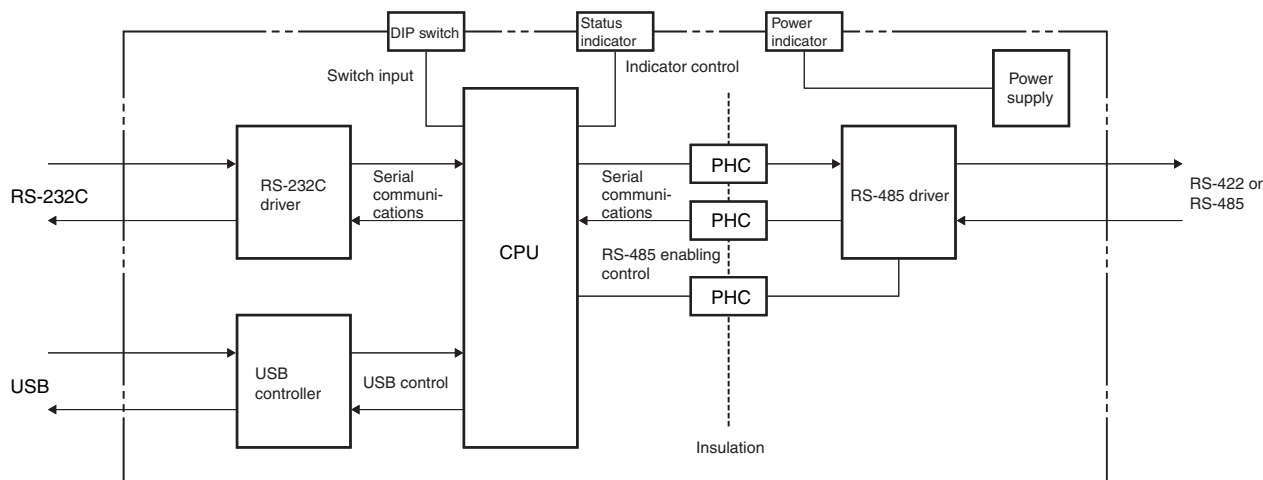

External Connections

RS-485 Connection

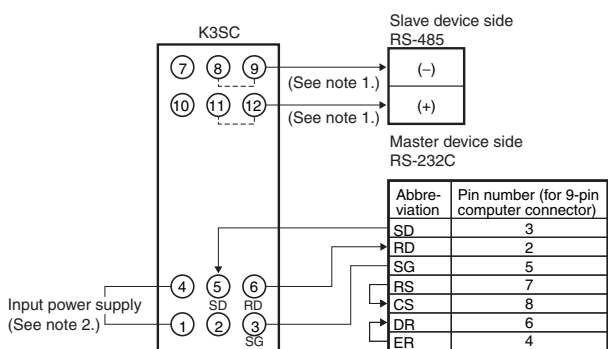

- Note:** 1. If RS-485 is selected as the communications method (i.e., pin 9 of the DIP switch is set to OFF), terminals 8 and 9, and terminals 11 and 12 are connected internally.
2. Either a 100 to 240-VAC or 24-VAC/VDC (no polarity) input power supply is used.

RS-422 Connection

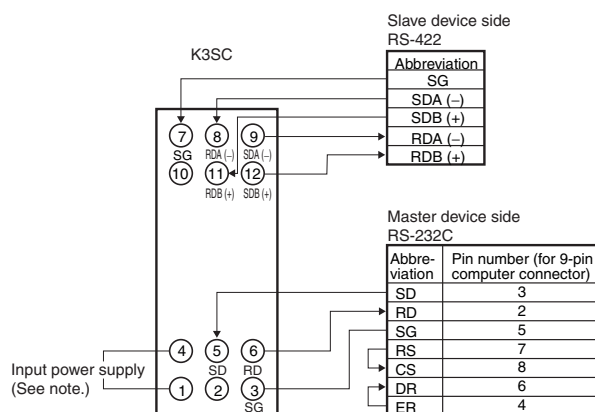

- Note:** Either a 100 to 240-VAC or 24-VAC/VDC (no polarity) input power supply is used.

Connecting an RS-232C or USB Master Device to an RS-422/485 Slave Device

First set the same communications conditions (baud rate, stop bits, data length, and parity) for the master device, the Interface Converter, and slave devices.

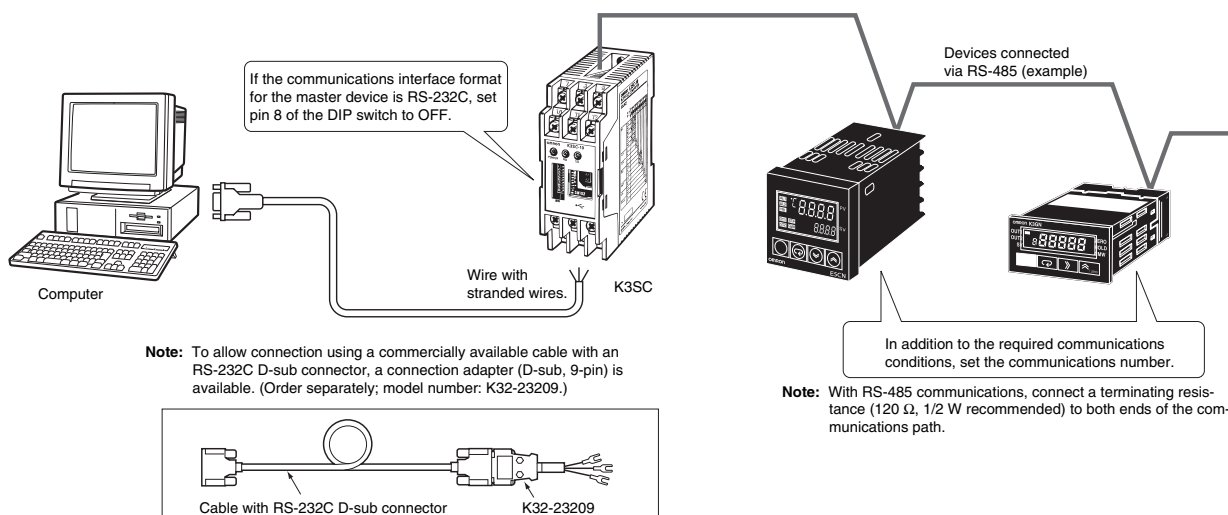

- Note:** 1. 1-to-N connection via OMRON NT Link communications is not supported.
2. If the communications interface format for the master device is USB, obtain a commercially available USB cable and download the USB driver for the K3SC from the OMRON web site.

Connecting a USB Master Device to an RS-232C Slave Device

First set the same communications conditions (baud rate, stop bits, data length, and parity) for the master device, the Interface Converter, and slave devices.

Note: There is no isolation between the USB and RS-232C sides.

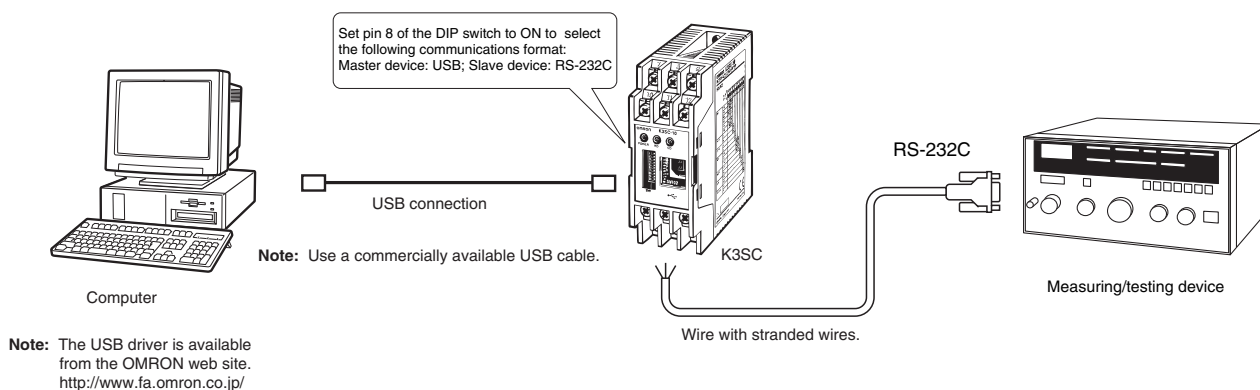

Operation

■ Communications Settings Switch

Use this switch to set the communications conditions for the K3SC to those used by connected devices.

Setting ON↔OFF	Baud rate						Data length		Stop bits		Parity			Configuration			Echoback *2				
	1,200 bps	2,400 bps	4,800 bps	9,600 bps	19,200 bps	38,400 bps	7	8	2	1	Even	Odd	None	Master: USB	Master: RS-232C or USB *1	Slave: RS-232C	Slave: RS-485	Slave: RS-422	OFF (with-out)	ON (with)	
1 <input type="checkbox"/>	ON	OFF	ON	OFF	ON	OFF															
2 <input type="checkbox"/>	OFF	ON	ON	OFF	OFF	ON															
3 <input type="checkbox"/>	OFF	OFF	OFF	OFF	ON	ON															
4 <input type="checkbox"/>							OFF	ON													
5 <input type="checkbox"/>									OFF	ON											
6 <input type="checkbox"/>											OFF	ON	OFF								
7 <input type="checkbox"/>											OFF	OFF	ON								
8 <input type="checkbox"/>														ON	OFF						
9 <input type="checkbox"/>															OFF	ON					
0 <input type="checkbox"/>																			OFF	ON	

Note: 1. All pins are factory-set to OFF.

2. When using RS-422 full-duplex communications, turn OFF pin 0.

***1.** When using the communications configuration with RS-232C or USB set for the master device and RS-422 or RS-485 set for the slave device, use either RS-232C or USB (but not both) on the master device side.

***2.** What is Echoback

With PC communications, for example, echoback relays the characters transmitted from the PC back to the user via the communications software, modem, or host computer.

Echoback is used with full-duplex communications (bi-directional communications) using RS-232C and RS-422.

OMRON's CompoWay/F and Modbus communications protocols use a higher-level command/response method (RS-485 communications method), enabling half-duplex communications with no echoback.

Full-duplex communications: Simultaneous data transmission and reception

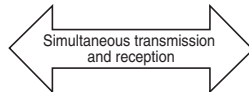

Half-duplex communications: Transmission and reception are performed alternately

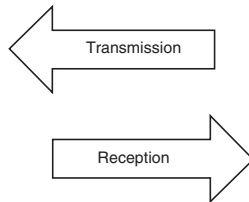

CompoWay/F, Modbus communications protocols

When echoback is ON, extra characters are added to the received data, resulting in a communications error.

Nomenclature

Terminal Cover

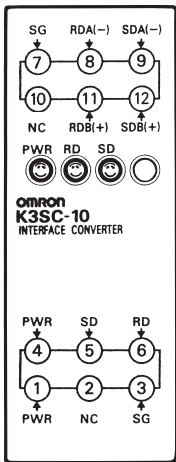

Power Indicator
Lights (green) when power is supplied.

Communications Setting Switch
Used to set the communications conditions for connected devices.

Communications Setting Switch

Switch	Setting
1	Baud rate
2	
3	
4	Data length
5	
6	Parity
7	Master device
8	Slave device
9	Echoback
10	

K3SC without Terminal Cover

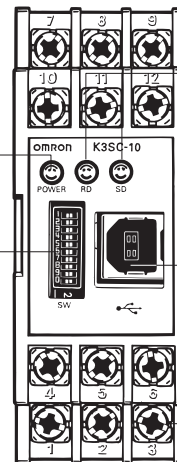

Communications Status Indicators
Light (yellow) during communications.

- RS-232C/USB ↔ RS-422/485:
RD: Lights when receiving RS-422/485 communications.
SD: Lights when sending RS-422/485 communications.
- USB ↔ RS-232C:
RD: Lights when receiving RS-232C communications.
SD: Lights when sending RS-232C communications.

USB Port
Port for USB connections. Use this port if the master device is a USB device.

M3.5 Terminal Screw

Note: Cover the terminals to prevent electric shock.

Caution: Be sure to use the K3SC-10 with the terminal cover mounted when using in machinery that must conform to EN/IEC standards.

Dimensions

K3SC-10

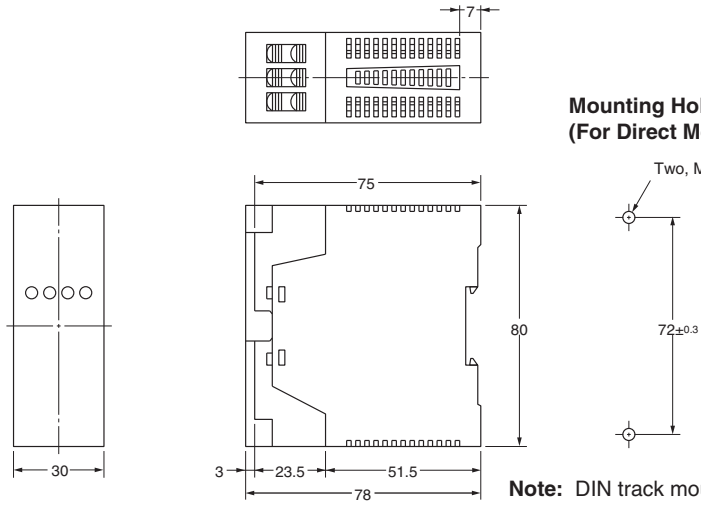
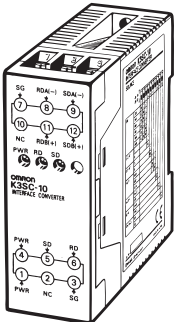

Mounting Hole Dimensions (For Direct Mounting)

Two, M4 or 4.3-dia. holes

Note: DIN track mounting is also possible.

Safety Precautions

⚠ CAUTION

Do not touch any of the terminals while power is being supplied. Doing so may result in electric shock.



Do not allow metal objects or wire cuttings to enter the product. Doing so may result in electric shock, fire, or malfunction.



Do not attempt to disassemble, repair, or modify the product. Any attempt to do so may result in malfunction, fire, or electric shock.



Make sure that the power supply voltage is within the specified range. Otherwise, damage or burning may result.



Be sure to tighten the terminal screws to the specified torque. Loose screws may result in burning or malfunction. The recommended tightening torque is 0.78 N·m.



■ General Precautions

- Do not mount the product in the following places:
 1. Locations subject to shock or vibration
 2. Outdoor locations or locations subject to direct sunlight, wind, or rain.
 3. Locations subject to temperatures or humidity outside the specified ranges
 4. Locations subject to condensation or icing
 5. Locations subject to large amounts of dust
 6. Locations subject to flammable gases or objects
 7. Locations subject to corrosive gases (in particular sulfide or ammonia gases)
- Be sure to check power supply specifications, terminal numbers, and polarities before performing wiring.
- Turn OFF the power supply before performing installation or wiring.
- Turn OFF the power supply before removing the terminal cover. Accidentally touching the terminals may result in electric shock.
- Do not connect anything to unused terminals.

■ Correct Use

- Perform wiring with crimp terminals that are suitable for M3.5 screws.
- Install the product as far away as possible from devices that generate strong high-frequency noise (e.g., high-frequency welders) or surges.
- Do not pull on the USB cable. Doing so may cause the cable to come loose.
- Almost all application programs run with the K3SC driver, which provides a virtual communications port for USB communications. Some application programs do not run, because this driver does not support all of the API functions.
- The K3SC-10 is not simply a voltage level converter. Communications data is converted by a built-in CPU. Depending on communications conditions, processing may not be able to keep up with communications, and occasionally data corruption or data omissions may occur. If necessary, reduce the baud rate or the frequency of communications, or take other suitable countermeasures.

ALL DIMENSIONS SHOWN ARE IN MILLIMETERS.

To convert millimeters into inches, multiply by 0.03937. To convert grams into ounces, multiply by 0.03527.

In the interest of product improvement, specifications are subject to change without notice.

Terms and Conditions Agreement

Read and understand this catalog.

Please read and understand this catalog before purchasing the products. Please consult your OMRON representative if you have any questions or comments.

Warranties.

(a) Exclusive Warranty. Omron's exclusive warranty is that the Products will be free from defects in materials and workmanship for a period of twelve months from the date of sale by Omron (or such other period expressed in writing by Omron). Omron disclaims all other warranties, express or implied.

(b) Limitations. OMRON MAKES NO WARRANTY OR REPRESENTATION, EXPRESS OR IMPLIED, ABOUT NON-INFRINGEMENT, MERCHANTABILITY OR FITNESS FOR A PARTICULAR PURPOSE OF THE PRODUCTS. BUYER ACKNOWLEDGES THAT IT ALONE HAS DETERMINED THAT THE PRODUCTS WILL SUITABLY MEET THE REQUIREMENTS OF THEIR INTENDED USE.

Omron further disclaims all warranties and responsibility of any type for claims or expenses based on infringement by the Products or otherwise of any intellectual property right. (c) Buyer Remedy. Omron's sole obligation hereunder shall be, at Omron's election, to (i) replace (in the form originally shipped with Buyer responsible for labor charges for removal or replacement thereof) the non-complying Product, (ii) repair the non-complying Product, or (iii) repay or credit Buyer an amount equal to the purchase price of the non-complying Product; provided that in no event shall Omron be responsible for warranty, repair, indemnity or any other claims or expenses regarding the Products unless Omron's analysis confirms that the Products were properly handled, stored, installed and maintained and not subject to contamination, abuse, misuse or inappropriate modification. Return of any Products by Buyer must be approved in writing by Omron before shipment. Omron Companies shall not be liable for the suitability or unsuitability or the results from the use of Products in combination with any electrical or electronic components, circuits, system assemblies or any other materials or substances or environments. Any advice, recommendations or information given orally or in writing, are not to be construed as an amendment or addition to the above warranty.

See <http://www.omron.com/global/> or contact your Omron representative for published information.

Limitation on Liability: Etc.

OMRON COMPANIES SHALL NOT BE LIABLE FOR SPECIAL, INDIRECT, INCIDENTAL, OR CONSEQUENTIAL DAMAGES, LOSS OF PROFITS OR PRODUCTION OR COMMERCIAL LOSS IN ANY WAY CONNECTED WITH THE PRODUCTS, WHETHER SUCH CLAIM IS BASED IN CONTRACT, WARRANTY, NEGLIGENCE OR STRICT LIABILITY.

Further, in no event shall liability of Omron Companies exceed the individual price of the Product on which liability is asserted.

Suitability of Use.

Omron Companies shall not be responsible for conformity with any standards, codes or regulations which apply to the combination of the Product in the Buyer's application or use of the Product. At Buyer's request, Omron will provide applicable third party certification documents identifying ratings and limitations of use which apply to the Product. This information by itself is not sufficient for a complete determination of the suitability of the Product in combination with the end product, machine, system, or other application or use. Buyer shall be solely responsible for determining appropriateness of the particular Product with respect to Buyer's application, product or system. Buyer shall take application responsibility in all cases.

NEVER USE THE PRODUCT FOR AN APPLICATION INVOLVING SERIOUS RISK TO LIFE OR PROPERTY OR IN LARGE QUANTITIES WITHOUT ENSURING THAT THE SYSTEM AS A WHOLE HAS BEEN DESIGNED TO ADDRESS THE RISKS, AND THAT THE OMRON PRODUCT(S) IS PROPERLY RATED AND INSTALLED FOR THE INTENDED USE WITHIN THE OVERALL EQUIPMENT OR SYSTEM.

Programmable Products.

Omron Companies shall not be responsible for the user's programming of a programmable Product, or any consequence thereof.

Performance Data.

Data presented in Omron Company websites, catalogs and other materials is provided as a guide for the user in determining suitability and does not constitute a warranty. It may represent the result of Omron's test conditions, and the user must correlate it to actual application requirements. Actual performance is subject to the Omron's Warranty and Limitations of Liability.

Change in Specifications.

Product specifications and accessories may be changed at any time based on improvements and other reasons. It is our practice to change part numbers when published ratings or features are changed, or when significant construction changes are made. However, some specifications of the Product may be changed without any notice. When in doubt, special part numbers may be assigned to fix or establish key specifications for your application. Please consult with your Omron's representative at any time to confirm actual specifications of purchased Product.

Errors and Omissions.

Information presented by Omron Companies has been checked and is believed to be accurate; however, no responsibility is assumed for clerical, typographical or proofreading errors or omissions.