

OMRON

Model ZW-5000

Controller for Fiber Coaxial Displacement Sensor

INSTRUCTION SHEET

Thank you for selecting OMRON product. This sheet primarily describes precautions required in installing and operating the product. Before operating the product, read the sheet thoroughly to acquire sufficient knowledge of the product. For your convenience, keep the sheet at your disposal.

TRACEABILITY INFORMATION:
Importer in EU:
OMRON Europe B.V.
Wegalaan 67-69,
NL-2132 JD Hoofddorp
The Netherlands

Manufacturer:
OMRON Corporation,
Shiokoji Horikawa, Shimogyo-ku,
Kyoto. 600-8530 JAPAN

The following notice applies only to products that carry the CE mark:
Notice:
This is a class A product. In residential areas it may cause radio interference, in which case the user may be required to take adequate measures to reduce interference.



9308560-9D

© OMRON Corporation 2017 All Rights Reserved.

PRECAUTIONS ON SAFETY

Meanings of Signal Words



WARNING Indicates a potentially hazardous situation which, if not avoided, will result in minor or moderate injury, or may result in serious injury or death. Additionally, there may be significant property damage.



CAUTION Indicates a potentially hazardous situation which, if not avoided, may result in minor or moderate injury or in property damage.

Alert Statements in This Sheet



This product is not designed or rated for ensuring safety of persons either directly or indirectly. Do not use it for such purposes.



Do not disassemble the product. Doing so may cause electric shock due to the high voltage portion. Burn also may result due to high temperature.
Do not attempt to disassemble, deform by pressure, incinerate, repair, or modify this product.



Do not use it exceeding the rated voltage. There is a possibility of failure and fire.



Do not connect amplifier units to AC power supply. Risk of explosion.



PRECAUTIONS FOR SAFE USE

- Please observe the following precautions for safe use of the products.
- Installation Environment**
 - Do not use the product in environments where it can be exposed to inflammable/explosive gas.
 - To secure the safety of operation and maintenance, do not install the product close to high-voltage devices and power devices.
 - Ensure clearances 30 mm or more wide and 10 mm or more wide on the top and both sides of the sensor controller main unit for intaking and exhausting air, respectively.
 - Hang the upper side of the groove on the back of the sensor controller on the DIN rail. After installing the sensor controller, be sure to confirm that the Sensor Controller is fixed surely.
 - When fixing the sensor controller with mounting screws, tighten the screws to the specified torque (1.2 Nm) described in this Instruction Sheet.
 - Avoid installing in the place with the vibrations as much as possible.
 - Do not install the product near any devices that generate noise. If there is no choice but to install the product in a noisy environment, make sure to take noise prevention measures.
 - Power Supply and Wiring**
 - Be careful when using a power supply with the overcurrent detection function. This sensor uses a DC-DC converter for the power supply circuit. The protection circuit may be activated due to surge current when using a power supply with the overcurrent detection function.
 - Recommended power supply: S8VS-06024 (OMRON: 24 VDC 2.5 A 60 W)
 - Do not apply voltages or AC power supplies that exceed the rated voltage (24 VDC±10%).
 - Do not reverse the polarity of the power connection.
 - Unstable voltage may cause unexpected operation of the sensor controller. If such condition is anticipated, use an UPS (Uninterruptible Power Supply).
 - Recommended UPS: S8BA Series (OMRON)
 - Open-collector outputs should not be short-circuited.
 - The load current must be equal to or less than the specified value.
 - High-Voltage lines and power lines must be wired separately from this product. Wiring them together or placing them in the same duct may cause induction, resulting in malfunction or damage.
 - Take sufficient safety measures such as fail-safe circuit to use the product.
 - Use a wire of the specified size for wiring. Do not connect the wire other than the specified size to the terminal block.
 - Fix the terminal block tightly to protect from accidental injury by pushing the release button on the attached terminal block with a screwdriver.
 - Supply power from a DC power supply for which measures have been applied to prevent high voltages (e.g., a safety extra low voltage circuit).
 - The length of the power supply cable should be as short as possible.
 - For the frame ground terminals, the terminal screw and crimp terminal of the specified size must be used. Do not directly connect the merely twisted wires to the frame ground terminals.
 - Crimp terminal: 8.5 mm max.
 - Terminal screw: M4
 - Perform class D grounding (the ground resistance of 100 ohm or less). Set the grounding point as close as possible and the length of the grounding wire as short as possible.
 - Do not share the grounding wire with other device or do not connect the grounding wire to the beam of a building. Otherwise an adverse effect may occur.
 - Do not connect this product with the same power supply as applied to an apparatus which might cause noises.
 - Always turn off the power of the main unit before taking the following actions. Not doing so may result in malfunction.
 - Connecting or wiring the cable
 - Mounting or removing the connector
 - Mounting or removing the Calibration ROM
 - Before turning on the power after the wiring is completed, verify that the power is correct, that there are no incorrect connections such as a shorted load circuit, and that the load current is suitable. Incorrect wiring may cause damage and failures.
 - When inserting or removing the EtherCAT cable, be careful not to stress the calibration ROM
 - Handling of the fiber cable
 - Using the product without observing the following might damage the fiber cable.
 - Use the fiber cable with a bend radius of 20 mm or more
 - Avoid the root of the fiber connector from being stressed by the bend.
 - Do not pull the fiber cable strongly.
 - Do not step on the fiber cable or put anything heavy on it.
 - Avoid applying torsional stress on the fiber cable.
 - When connecting the fiber connector, do not forcibly push it or apply torsional stress to it.
 - Others**
 - Do not look into the light injection port directly.
 - Do not use in safety circuits for atomic energy or that are critical for human life.
 - Do not attempt to disassemble, deform by pressure, incinerate, repair, or modify this product.
 - When disposing of the product, treat as industrial waste.
 - Connect a dedicated device (Sensor Head, Calibration ROM, fiber cable or RS-232C cable). Use of other devices may result in fire, explosion, malfunction or failure.
 - Do not cut off the fiber cable. Otherwise, you might be injured by the glass of the cut portion. In addition, the Sensor Controller does not operate normally if the cable is cut off.
 - If you notice an abnormal condition such as a strange odor, extreme heating of the unit, or smoke, immediately stop using the product, turn off the power, and consult your dealer.
 - Do not drop or impose shock on the product.
 - Ensure that all components which have locking mechanisms are locked before using the product.

- Regulations and standards**
 - This sensor complies with EMC directive and EN standards as follows:
 - EN61326-1
 - Electromagnetic environment : Industrial electromagnetic environment (EN/IEC 61326-1 Table 2)
 - The following condition is applied to the immunity test of this product:
 - While receiving electromagnetic interference, the voltage/current output might vary within ±3% of full scale.
 - EMC Directive No.2014/30/EU

PRECAUTIONS FOR CORRECT USE

- Observe the following to prevent failure, malfunctioning, and adverse effects on performance and the device.
- Installation site**
 - Do not install in the following locations:
 - Locations where the ambient temperature exceeds the rated temperature range.
 - Locations subject to sudden temperature changes (where condensation will form).
 - Locations where the relative humidity is below or above 35% to 85%.
 - Locations where there are corrosive or flammable gases.
 - Locations where there is dust, salt, or iron powder.
 - Locations where the device will be subjected to direct vibration or shock.
 - Locations where there is strong scattered light (laser light, arc welding light, ultraviolet light, etc.)
 - Locations exposed to direct sunlight or next to a heater.
 - Locations where there is splashing or spraying of water, oil, or chemicals.
 - Locations where there is a strong electrical or magnetic field.
 - Power and cable connections**
 - When using a commercially available switching regulator, make sure that the Frame ground terminal is grounded.
 - Wire without placing load on the cables/connectors.
 - If there are surges on your power line, connect a surge absorber as appropriate for your conditions of use.
 - Use the product with the specified voltage. Applying a voltage or AC voltage that exceed the rating may result in burning or explosion of circuit components.
 - To extend the fiber cable between the Sensor Head and Sensor Controller, an optional extension fiber cable (ZW-XF50□ [R]) must be used. Only one extension fiber cable can be connected.
 - Use the Sensor Head and Calibration ROM of the same serial number. Operation will fail if those with different serial numbers are used.
 - Use the dedicated Setup Software. Using the other software may result in malfunction of the product.
 - Do not turn off the power supply while saving data into the Sensor Controller built-in memory. Doing so may damage the data.
 - When the fiber cable is not connected, attach the provided protective caps to the fiber adapter and fiber connector.
 - Leaving the product without the protective caps may result in malfunction caused by adhesion of a foreign material.
 - When connecting the sensor head at initial startup after factory shipment, or connecting another type of the sensor head to the sensor controller at previous startup, be sure to initialize the setup with the sensor head connected to the sensor controller.
 - Warning Up**
 - After turning on the power supply, allow the Sensor Controller to stand for at least 30 minutes before use. The internal temperature of the Sensor Controller are unstable immediately after the power supply is turned on and attempting measurement may result in inconsistent measurement values.
 - Maintenance**
 - Do not use thinner, benzene, acetone or kerosene to clean the Sensor Head, fiber cable or Sensor Controller. If considerable foreign matter or dust collects on the Sensor Head or receiver/emitter of the Sensor Controller, use a blower brush (for camera lenses) to blow off the foreign matter. Avoid blowing it off with your breath. For a small amount of foreign matter or dust, gently wipe with a soft cloth. Do not wipe hard. If the receiver/emitter is damaged, malfunction or measurement error may result.
 - Do not touch the end face of the fiber cable of the sensor head. Otherwise, performance deterioration might occur. If the end face touches anything or becomes unclear, wipe off the dirt with option product ZW-XCL□, the commercially available dedicated fiber cleaner, or a dry soft cloth. Do not use cloth soaked in alcohol. Otherwise, dirt might adhere again.
 - To clean the fiber connector of the controller, use option product ZW-XCL□.
 - If inserting/extracting the sensor head frequently, use of the repeatedly usable commercially available dedicated fiber cleaner is recommended. For the recommended fiber cleaner, refer to the operation manual of the sensor head (ZW-5000 series sensor head).
 - Clean the vent hole periodically so as not to be clogged with dust or particulate. If the vent hole is clogged, heat is not dissipated from inside, leading a failure.
 - Sensing Object For Sensor Head**
 - Depending on the material/shape of the object, the object cannot be measured or can be measured but accuracy is poor: Transparent objects, objects with a low reflective sensor ratio, objects smaller than the spot diameter, objects with a large curvature, excessively inclined objects, objects with thin film on the surface, etc.
 - Effects of surrounding lightings**
 - Avoid installing the product at a location where the emitter/receiver of the Sensor Head is exposed to strong lighting. If the objects has reflective surface, malfunction of the product may occur due to light reflection. Prevent it by covering the lighting.
 - Influence of air current**
 - Measured values may vary due to slow air current around the Sensor Head. In such case, put a cover around the Sensor Head.
 - Operation beyond the measurement range**
 - As this sensor is sensitive, malfunction may occur beyond the measurement range. In such case, shorten the exposure to light or raise the level of the background removal.
 - Service life of writing to sensor controller built-in EEPROM**
 - When the zero resetting memory is preset ON, data are written in the EEPROM (non-volatile memory) in the sensor controller every time the memory is reset to zero. The life of this EEPROM as a writable memory is approximately one million times. So, if using the memory with setting it ON, be careful with the life of the writable memory.
 - Coverage of fixing support**
 - Fixing support of component replacement by fiber breaking, lens damage and so on is not accepted.

Parts Names and Functions

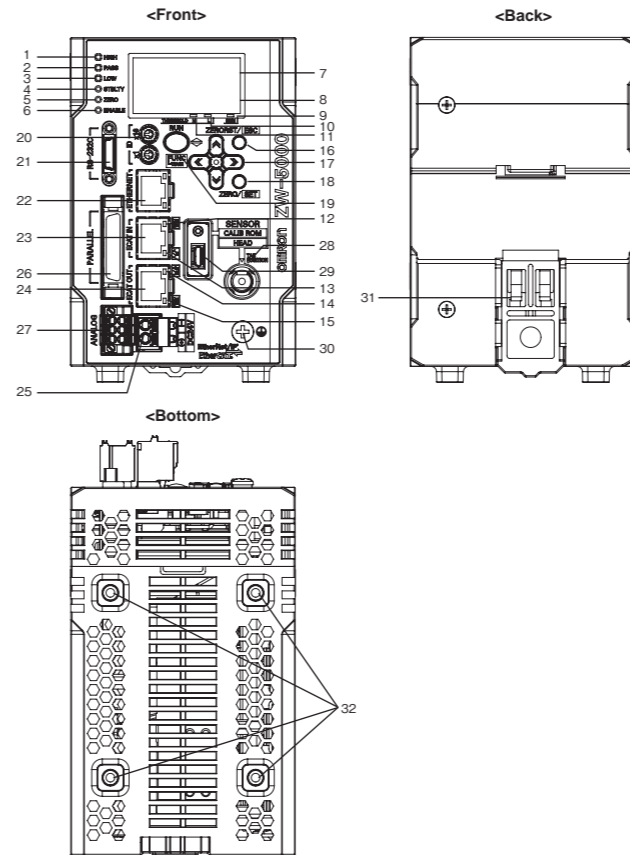

<Front>

Display section

No.	Name (color)	Function
1	HIGH indicator (Orange)	Lights when the judgment result is HIGH (HIGH threshold < measured value).
2	PASS indicator (Green)	Lights when the judgment result is PASS (LOW threshold ≤ measured value ≤ HIGH threshold).
3	LOW indicator (Orange)	Lights when the judgment result is LOW (measured value < LOW threshold).
4	STABILITY indicator (Green)	Lights when the first surface is within the measuring range. Turns OFF when the measured value is outside the measuring range.
5	ZERO indicator (Green)	Lights when zero reset setting is made.
6	ENABLE indicator (Green)	Lights when measurement is enabled. Turns off when measurement is disabled (e.g. when the received light amount is excessive or insufficient, when the Calibration ROM is not connected, or when FUNC mode is not active for measurement).
7	Main digital indicator (White)	Shows a measurement value or function name.
8	Sub digital indicator (Green)	Shows the supplemental information of the measurement value or set value of the function.
9	RUN indicator (Green)	Lights at RUN mode and turns off at FUNC mode.
10	THRESHOLD-L indicator (Orange)	Lights when a LOW threshold is shown on the sub digital.
11	THRESHOLD-H indicator (Orange)	Lights when a HIGH threshold is shown on the sub digital.
12	ECAT RUN indicator (Green)	Lights when EtherCAT communications is available.
13	L/A IN indicator (Green)	Lights when connected to the EtherCAT device, and blinks during communications (data inputs).
14	L/A OUT indicator (Green)	Lights when connected to the EtherCAT device, and blinks during communications (data outputs).
15	ECAT ERROR indicator (Red)	Lights when the EtherCAT communications error occurs.

Operating section

No.	Name	Function
16	ZERORST/ESC key	Functions differ depending on operating mode.
17	← (LEFT) key → (RIGHT) key ↑ (UP) key ↓ (DOWN) key	
18	ZERO/SET key	
19	Mode switch key	
20	Node address setting switch (in hexadecimal)	Used for station address settings as an EtherCAT communications device. The setting range is 0x01(1) to 0xFF(255).

Connector/terminal

No.	Name	Function
21	RS-232C connector	Used when connecting a PLC or PC via RS-232C port. Be sure to use a dedicated RS-232C cable. Otherwise malfunction or failure may result. <ul style="list-style-type: none"> For PLC/programmable terminal: ZW-XPT2 For PC: ZW-XRS2
22	Ethernet connector	Used to connect a PLC or PC via Ethernet. Be sure to use a commercial Ethernet cable that satisfies the following conditions: <ul style="list-style-type: none"> Category 5e or higher, length 30 m or shorter RJ45 connector (8-pin modular jack) 1:1 connection: Select a cross cable. Connection via network HUB: Select a straight cable.
23	EtherCAT connector (IN)	Used when connecting to the EtherCAT compatible device. Use a recommended EtherCAT cable.
24	EtherCAT connector (OUT)	Used when connecting to the EtherCAT compatible device. Use a recommended EtherCAT cable.
25	24V input terminal block	Connects the 24VDC power supply of the Sensor Controller.
26	32-pole expansion connector	Connects parallel I/O (Judgment output, ALARM output, BUSY output, ENABLE output, bank No. output, SYNC/LOG/LOGERR output, STABILITY output, LOGSTAT output, LOGERR output, TASKSTAT output, ZERO input, RESET input, TIMING input, LIGHT OFF input, LOGGING input, bank No. select input, SYNC/TRIG input). Ensure that the cable is 2 m or less long.
27	Analog output terminal block	Connects an analog voltage output and analog current output.
28	Fiber adapter	Connects a fiber connector.
29	ROM connector	Connects the Calibration ROM.
30	Frame ground terminal	A terminal for frame grounding. Connects a grounding wire.

<Back>

No.	Name	Function
31	DIN track mounting hook	Used when securing the Sensor Controller to the DIN track.

<Bottom>

No.	Name	Function
32	Mounting screw hole	Used to secure the Sensor Controller with screws

Specifications

Item	Specifications
Input/output type	NPN/PNP
Total number of Sensor Heads connected	1
Operating Sensor Head	ZW-S50□□/SP50□□/SPR50□□
Safety of LED	Risk Group 1 (IEC 62471)
Segment display	Main digital indicator: 11-segment white display, 6 digits Sub digital indicator: 11-segment green display, 6 digits
Indicators	Status indicator: HIGH (Orange), PASS (Green), LOW (Orange), STABILITY (Green), ZERO (Green), ENABLE (Green), THRESHOLD-H (Orange), THRESHOLD-L (Orange), RUN (Green)
EtherCAT display	ECAT RUN (Green), L/A IN (Link/Activity IN) (Green), L/A OUT (Link/Activity OUT) (Green), ECAT ERR (Red)
External interface	Ethernet: 100BASE-TX/10BASE-T non-procedural (TCP/UDP), EtherNet/IP EtherCAT: EtherCAT-specific protocol 100BASE-TX RS-232C: 115,200 bps max.
Analog output terminal block	Analog voltage output (OUTV): -10 V to +10 V, output impedance: 100 Ω Analog current output (OUTA): 4 mA to 20 mA, maximum load resistance: 300Ω
32-pole expansion connector	Judgment outputs (HIGH/PASS/LOW): Transistor output method Busy output (BUSY): Output voltage: 21.6 to 30 VDC Load current: 50 mA max. Alarm output (ALARM): ON residual voltage: 2 V max. Enable output (ENABLE): OFF leakage current: 0.1 mA max. Sync flag output (SYNFLAG) Trigger busy output (TRIGBUSY) Logging state output (LOGSTAT) Logging error output (LOGERR) Stability output (STABILITY) Task state output (TASKSTAT) LIGHT OFF input (LIGHT OFF): DC input method Input voltage: 24 VDC±10% (21.6 to 26.4 VDC) Zero reset input (ZERO): Input current: 7 mA Typ. (24 VDC) Timing input (TIMING): ON voltage/ON current: 19 V/3 mA min. Reset input (RESET): OFF voltage/OFF current: 5 V/1 mA max. Sync input (SYNC) Trigger input (TRIG) Logging input (LOGGING)
Bank selection	Bank output during selection (BANK_OUT1 to 3): Transistor output method Output voltage: 21.6 to 30 VDC Load current: 50 mA max. ON residual voltage: 2 V max. OFF leakage current: 0.1 mA max. Bank selection input (BANK_SEL1 to 3): DC input method Input voltage: 24 VDC±10% (21.6 to 26.4 VDC) Input current: 7 mA Typ. (24 VDC) ON voltage/ON current: 19 V/3 mA min. OFF voltage/OFF current: 5 V/1 mA max.
Main functions	Exposure time: Auto/fixd Measurement cycle *1: 80 μs to 1600 μs Specified materials: Standard/mirror surface/rough surface Measurement items: Height/thickness/operation Filter processing: Median/average/differentiation/high-pass/low-pass/band-pass Outputs: Scaling/holds/zero reset/measurement value logging/Keep clamp Display: Measurement value/threshold/analog output voltage value or current value/judgment result/resolution/light intensity/Internal logging state/incident light peak level Total number of registrations: Standard Mode: Max. 8 bank, Judgment Value Mode: Max. 32 bank Task processing: Multitasks (up to 4 tasks per bank) System: Saving/initialization/measurement information display/communication setting/Sensor Head calibration/key lock/zero reset memory/timing input
Ratings	Power supply voltage: 21.6 V to 26.4 VDC (including ripple) Current consumption: 800 mA max. Insulation resistance: Between all lead wires and FG terminal: 20 MΩ (250 VDC) Dielectric strength: Between all lead wires and FG terminal: 500 VAC, 50/60 Hz, 1 min. Degree of protection: IP20 (IEC60529)
Environmental immunity	Vibration resistance (destruction): 10 to 55 Hz, 0.35-mm half amplitude 50 min each in X, Y, and Z directions Shock resistance (destruction): 150ms* 3 times each in six directions (up/down, left/right, forward/backward) Ambient temperature range: Operating: 0 to 40°C, Storage: -15 to +60°C (with no icing or condensation) Ambient humidity range: Operating and storage: 35% to 85% (with no condensation)
Grounding	Class D grounding (grounding resistance 100 Ω max.)* Conventional class 3 grounding
Material	Case: PC
Weight	Approx. 900 g (main unit only), Approx. 150 g (parallel cable)
Accessories	Parallel cable(ZW-XCP2E), 10 bottles of fiber cleaner (ZW-XCL), Fiber adapter cap (1 piece), Strap (1 piece), Instruction Sheet(This Instruction Sheet), Membership Registration Sheet, Precautions

The Export Trade Control Order compatible Sensor Controller (ZW-5000T) is available. When using this Sensor Controller, the minimum resolution is 0.25 μm regardless of the connected Sensor Head and setting conditions. *1 If an extension fiber cable 5 m long or more is connected, the setup range of measurement cycle (exposure time) must be changed. For details, refer to "Setting Measurement Cycle" in the user's manual.

EtherCAT communications specifications

Item	Specifications
Communications standards	IEC 61158 Type12
Physical layer	100BASE-TX (IEEE802.3)
Connector	RJ45x2 EtherCAT IN: EtherCAT input EtherCAT OUT: EtherCAT output
Communication medium	Category 5e or higher twisted pair cable (Aluminum tape and woven double shielded straight cable is recommended.)
Communication distance	Distance between nodes: within 100m
Process data	Variable PDO mapping
Mail box (CoE)	Emergency message, SDO request, SDO response, SDO information
Distributed clock	Synchronization in DC mode
LED display	L/A IN (Link/Activity IN)x1 L/A OUT(Link/Activity OUT)x1 ECAT RUNx1 ECAT ERRx1

Input circuit

Item	Specifications	
Model	ZW-5000□	
Input type *1	NPN	PNP
Input voltage	24 VDC±10% (21.6 to 26.4 V)	24 VDC±10% (21.6 to 26.4 V)
Input current	7 mA Typ. (24 VDC)	7 mA Typ. (24 VDC)
ON voltage/ON current *2	19 V min./3 mA min.	19 V min./3 mA min.
OFF voltage/OFF current *3	5 V max./1 mA max.	5 V max./1 mA max.
ON delay	0.1 ms max.	0.1 ms max.
OFF delay	0.1 ms max.	0.1 ms max.
I/O circuit diagrams *4		

*1 For both NPN/PNP. Wire the product properly according to the specifications of the external devices.

*2 ON voltage/ON current

A voltage value or current value that turn the input from OFF to ON. An ON voltage value is a potential difference between COM_IN1/2/3 and input terminals.

*3 OFF voltage/OFF current

A voltage value or current value that turn the input from ON to OFF. An OFF voltage value is a potential difference between COM_IN1/2/3 and input terminals.

*4 The table below shows the correspondence between COM_IN (input common) and input signals.

Name	COM_IN1	COM_IN2	COM_IN3
Input signal name	TIMING	SYNC/TRIG	BANK_SEL1
	RESET		BANK_SEL2
	ZERO		BANK_SEL3
	LIGHT_OFF		LOGGING

Important

Chattering measures

The sensor is equipped with a chattering countermeasure function. However, if chattering of 100 μs or higher occurs, it is unable to prevent incorrect input due to chattering. (Variation of input signals less than 100 μs is ignored. Input signals are determined when the same level is kept for 100 μs or more.)

Be sure to use contactless input signals such as SSR or PLC transistor output. If contact signals (with relays) are used, TIMING input might occur again due to bounce of the contact while measurement is performed.

Output circuit

Item	Specifications	
Model	ZW-5000□	
Output type *1	NPN	PNP
Output voltage	21.6 to 30 VDC	21.6 to 30 VDC
Load current	50 mA max.	50 mA max.
ON residual voltage	2 V max.	2 V max.
ON leakage current	0.1 mA max.	0.1 mA max.
I/O circuit diagrams *2		

*2 For both NPN/PNP. Wire the product properly according to the specifications of external devices.

*1 The table below shows the correspondence between COM_OUT (output common) and each output signal.

Terminal name	COM_OUT1	COM_OUT2	COM_OUT3
Output signal name	HIGH	BANK_OUT1	STABILITY
	PASS	BANK_OUT2	LOGERR
	LOW	BANK_OUT3	LOGSTAT
	ALARM		SYNCFLG/TRIGBUSY
	BUSY		TASKSTAT
	ENABLE		

Important

Connect a load corresponding to the output specifications. Short-circuiting the terminals may damage the Sensor.

Do not allow the load current to exceed the rated value. Exceeding the rated value may damage the output circuit.

32-pole expansion connector

Used for judgment output or control input.

Applicable connector: FX2B series (HIROSE ELECTRIC Co., Ltd.)

The parallel cable for 32-pole expansion connector (ZW-XCP2E) is bundled.

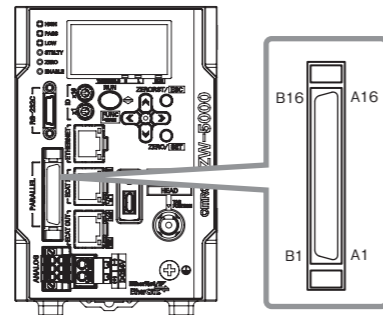

Terminal No.	Signal name	Description	Wire color of ZW-XCP2E
A1	LOGGING	LOGGING input	Brown
A2	BANK_SEL3	Bank selection input	Red
A3	BANK_SEL2		Orange
A4	BANK_SEL1		Yellow
A5	COM_IN3	COM3 for input	Green
A6	TASKSTAT	TASKSTAT output	Blue
A7	SYNCFLG/TRIGBUSY	SYNCFLG/TRIGBUSY input	Purple
A8	LOGSTAT	LOGSTAT output	Gray
A9	LOGERR	LOGERR output	White
A10	STABILITY	STABILITY output	Black
A11	COM_OUT3	COM3 for output	Brown
A12	NC	Not used.	Red
A13	NC		Orange
A14	NC		Yellow
A15	SYNC/TRIG	SYNC/TRIG output	Green
A16	COM_IN2	COM2 for input	Blue
B1	BANK_OUT3	Bank No. output	Brown
B2	BANK_OUT2		Red
B3	BANK_OUT1		Orange
B4	COM_OUT2	COM2 for output	Yellow
B5	ENABLE	ENABLE output	Green
B6	BUSY	BUSY output	Blue
B7	ALARM	ALARM output	Purple
B8	LOW	LOW judgment output	Gray
B9	PASS	PASS judgment output	White
B10	HIGH	HIGH judgment output	Black
B11	COM_OUT1	COM1 for output	Brown
B12	LIGHT_OFF	LIGHT OFF input of sensor head	Red
B13	ZERO	ZERO input of sensor head	Orange
B14	RESET	RESET input of sensor head	Yellow
B15	TIMING	TIMING input of sensor head	Green
B16	COM_IN1	COM1 for input	Blue

Important

Cut off unnecessary signal cables so as not to contact some other signal cable.

24V input terminal block

Used for 24VDC power supply input.

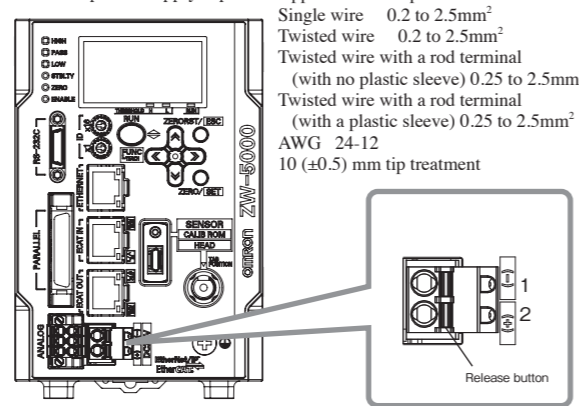

Terminal No.	Signal name	Description
1	24VDC(-)	Terminal for external power supply (0 V)
2	24VDC(+)	Terminal for external power supply (24 V)

Important

Wiring with the power being supplied may cause short circuit and failure of the product. Wire the power supply without feeding power.

Do not connect the product with the same power supply as applied to an apparatus which might cause noises. If wiring the product with the same line or duct of other equipment, electromagnetic induction might influence the product, causing malfunction or damage of the sensor.

Do not turn off the power during the initial processing directly after turning on the power of the sensor controller because the Sensor Controller internal memory is being accessed.

Hold the terminal block securely to prevent getting injured when pushing in the release button using a screwdriver.

Keep the length of the wire as short as possible.

Analog output terminal block

Used for analog output.

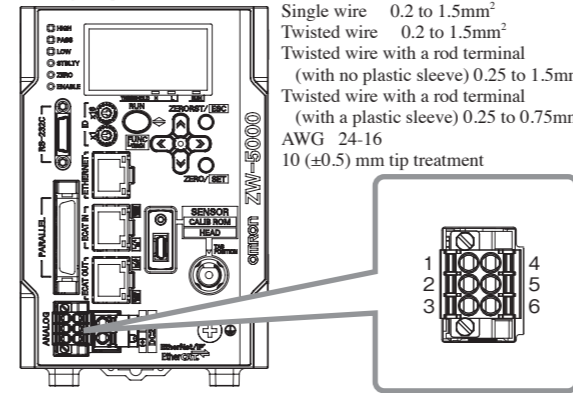

Applicable wire specifications:

Single wire 0.2 to 1.5mm²

Twisted wire 0.2 to 1.5mm²

Twisted wire with a rod terminal

(with no plastic sleeve) 0.25 to 1.5mm²

(with a plastic sleeve) 0.25 to 0.75mm²

AWG 24-16

10 (±0.5) mm tip treatment

Terminal No.	Signal name	Description
1	OUT(V)	The measured value is outputted as a voltage value of -10 to +10 V. When measurement is impossible: Approx. +10.8 V (This is an initial value and selectable by the user.) When an alarm occurs: Approx. +10.8 V
2	OUT(A)	The measured value is outputted as a current value of 4 to 20 mA. When measurement is impossible: Approx. +20.8 mA (This is an initial value and selectable by the user.) When an alarm occurs: Approx. +20.8 mA
3	OUT OV	This is the 0V terminal for analog output.
4	NC	Not used.
5	NC	Not used.
6	NC	Not used.

Important

Keep unnecessary signal cables not contacting with other signal cables. The length of the wire should be kept as short as possible. Do not use it with the length of 30 m or longer.

Analog signal is not output if the following condition is satisfied.

When the EtherCAT output is enabled:

The cleaning method by using ZW-XCL

(1) Pulling out the cleaner

Pull out a cleaner from the bag so as not to make the tip portion of the cleaner dirty.

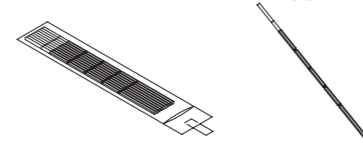

(2) Cleaning of the end face of the fiber connector of the Sensor Controller side

Insert the cleaner tip (white end face) into the fiber connector or connection adapter. Then, rotate the tip in the same direction around three times as pushing it onto the side face and the end face of the optical connector. When clearing is over, pull out the cleaner from the fiber connector slowly. If the fiber cable is used with an extension cable connected, clean the connection adapter, too in the same way.

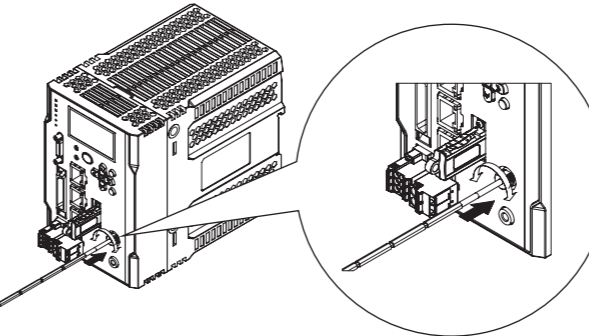

(3) Cleaning of the end face of the fiber connector of the sensor head side

Remove the cap of the fiber connector, and wipe up and down the end face of the fiber connector around three times.

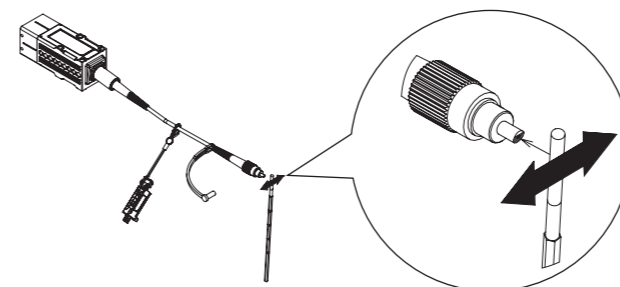

Important

The cleaner can only be used one time. Reusing the cleaner may result in dirt or scratches on the end surface, causing malfunctions or measurement errors. Discard after use.

Be sure to clean the fiber cleaner with the cloth for the cleaning part (white end face).

Notice for Korea Radio Law

사용자안내문

이 기기는 업무용 환경에서 사용할 목적으로 적합성평가를 받은 기기로서 가정용 환경에서 사용하는 경우 전파간섭의 우려가 있습니다.

Dimensions

(UNIT : mm)

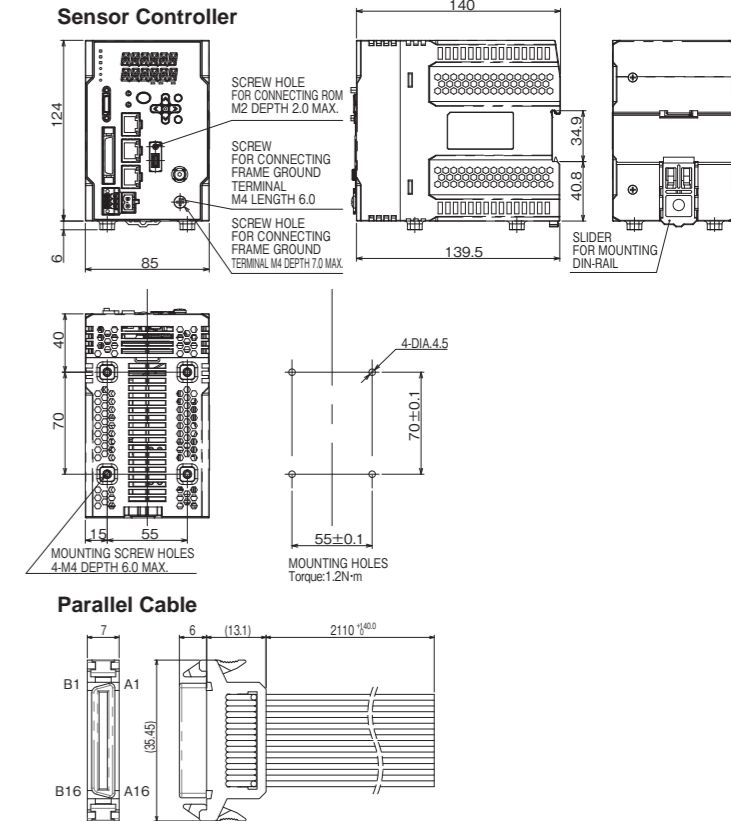

Relevant Manuals

Man. No.	Model	Manual name
Z362	ZW-8000□/7000□/5000□	Confocal Fiber Displacement Sensor ZW-8000/7000/5000 Series User's Manual
Z363	ZW-8000□/7000□/5000□	Confocal Fiber Displacement Sensor ZW-8000/7000/5000 Series User's Manual: Communication Settings
W504	SYSMAC-SE2□□□	Sysmac Studio Version 1 Operation Manual

Suitability for Use

Omron Companies shall not be responsible for conformity with any standards, codes or regulations which apply to the combination of the Product in the Buyer's application or use of the Product. At Buyer's request, Omron will provide applicable third party certification documents identifying ratings and limitations of use which apply to the Product. This information by itself is not sufficient for a complete determination of the suitability of the Product in combination with the end product, machine, system, or other application or use. Buyer shall be solely responsible for determining appropriateness of the particular Product with respect to Buyer's application, product or system. Buyer shall take application responsibility in all cases.

NEVER USE THE PRODUCT FOR AN APPLICATION INVOLVING SERIOUS RISK TO LIFE OR PROPERTY WITHOUT ENSURING THAT THE SYSTEM AS A WHOLE HAS BEEN DESIGNED TO ADDRESS THE RISKS, AND THAT THE OMRON PRODUCT(S) IS PROPERLY RATED AND INSTALLED FOR THE INTENDED USE WITHIN THE OVERALL EQUIPMENT OR SYSTEM.

OMRON Corporation Industrial Automation Company
Kyoto, JAPAN Contact: www.ia.omron.com

Regional Headquarters

OMRON EUROPE B.V.

Wegalaan 67-69, 2132 JD Hoofddorp
The Netherlands
Tel: (31)2356-81-300/Fax: (31)2356-81-388

OMRON ELECTRONICS LLC

2895 Greenspoint Parkway, Suite 200
Hoffman Estates, IL 60169 U.S.A.
Tel: (1) 847-843-7900/Fax: (1) 847-843-7787

OMRON ASIA PACIFIC PTE. LTD.

No. 438A Alexandra Road # 05-05/08 (Lobby 2),
Alexandra Technopark,
Singapore 119967
Tel: (65) 6835-3011/Fax: (65) 6835-2711

OMRON (CHINA) CO., LTD.

Room 2211, Bank of China Tower,
200 Yin Cheng Zhong Road,
PuDong New Area, Shanghai, 200120, China
Tel: (86) 21-5037-2222/Fax: (86) 21-5037-2200