

Rotary Positioner

H8PR-8

H8PR-8P

H8PR-16

H8PR-16P

H8PR-24

H8PR-24P

OPERATION MANUAL

OMRON

Precautions on Safety

● Safety indications and definitions for safe usage

This operation manual describes precautions required in using the H8PR Rotary Positioner safely. Precautions described here are very serious. Make sure that you obey them. Precautions are described by indications and symbols shown below.

WARNING

Incorrect product handling may cause serious injury or death.

● Explanation of graphic symbols



● Explosion Hazard
To signify the danger of explosion under certain circumstances.

● Safety Indications

WARNING

Never disassemble, deform, subject to heat over 100°C or dispose in fire. The product has a built-in lithium battery.
Fire, Explosion and Burn Hazard.



Contents

Section 1 Introduction	2
1-1 Features	2
Section 2 Ratings and Characteristics	6
2-1 Available Types	6
2-2 Ratings	6
2-3 Characteristics	7
2-4 Output Response Time	7
2-5 Dimensions	8
2-6 Connections	9
Section 3 Nomenclature and Settings	15
3-1 Nomenclature	15
3-2 Indicators	15
3-3 Selector Switches	16
Section 4 User Program	19
4-1 Separate Settings	19
4-2 Common Settings	21
4-3 Special Setting	21
Section 5 Program	26
5-1 Using Key Switches	26
5-2 Preparing to Program Common Settings	27
5-3 Changing and Checking Program	29
5-4 Special Setting	31
5-5 Specifying Encoder Shaft Revolution Direction	32
5-6 Programming with Teaching Function	31
Section 6 RUN	37
6-1 Changing Program during Execution	37
6-2 Control Outputs on Power Recovery	38
Appendix	41
Appendix A Error Messages	41
Appendix B Precautions	42
Appendix C Coding Sheet	45
C-1 Timing Chart	45
C-2 Coding Sheet	46
Appendix D Absolute Rotary Encoder E6F-AB3C-C	47
D-1 Features	47
D-2 Ratings/Characteristics	48
D-3 Output Stage Circuit Diagram	49
D-4 Output Mode	49
D-5 Dimensions	50
D-6 Accessories	50
D-7 Connector Pin Layout	51
D-8 Precautions	51

Section 1 Introduction

1-1 Features

OMRON H8PR Rotary Positioner is an efficient and economical multi-output electronic rotary positioner. Coupled with the specially-designed absolute-type rotary encoder E6F-AB3C-C, the Rotary Positioner performs electronically all the functions of conventional mechanical cam switches.

Seven main features of the Rotary Positioner are described below.

- (1) The control output can be programmed to turn ON/OFF in units of 1° rotation of the rotary encoder, eliminating the need to make troublesome adjustments necessary for mechanical cam switches.

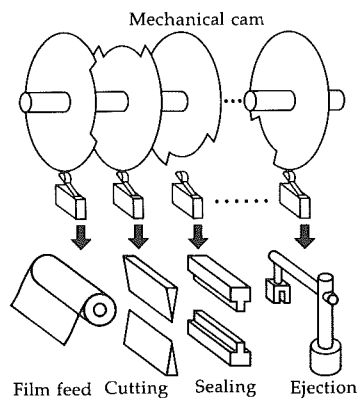
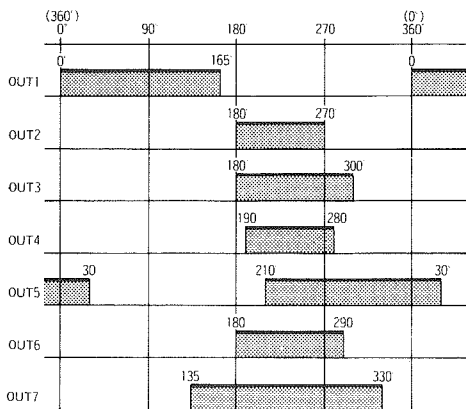

Operation chart for one full cycle controlled by Rotary Positioner

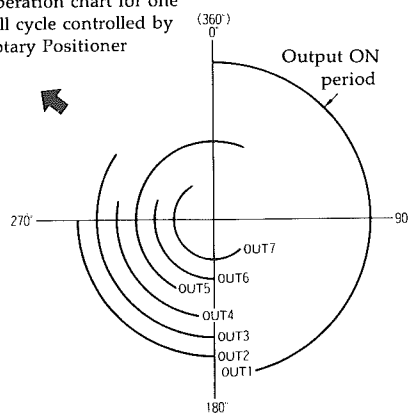

- (2) Each control output can be programmed to turn ON/OFF up to 10 times. The Rotary Positioner comes in three types: the H8PR-8 (P) with 8 separate control outputs, the H8PR-16 (P) with 16 separate control outputs, and the H8PR-24 (P), with fully 24 separate control outputs.

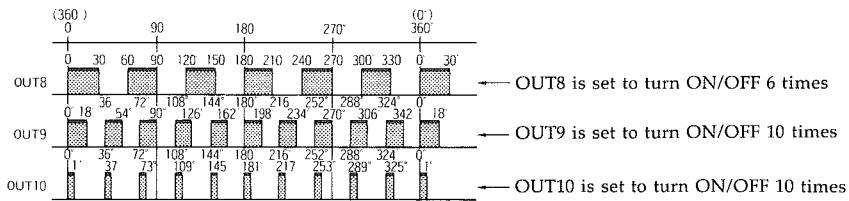

- (3) The point of origin can be adjusted at any point on the full 360° circumference. This simplifies installation of the encoder shaft since it is possible to set the present angle of the encoder as the origin. For example, suppose the encoder is connected to the Rotary Positioner with the encoder shaft at 45° from the point of origin when the Rotary Positioner is to execute the following program. The initial angular position of the encoder can be set as the origin and the Rotary Positioner can start its operation from there.

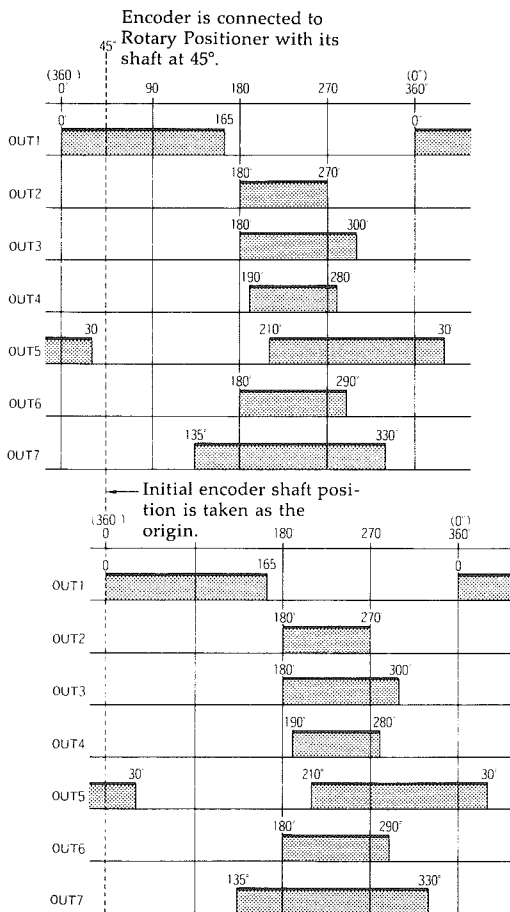

The encoder shaft can be at any angle when it is connected to the motor shaft.

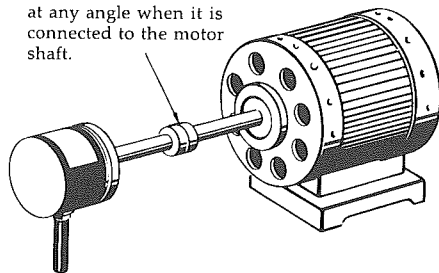

- (4) In case of power failure, it is possible to specify the "output start point" from which you wish the Rotary Positioner operation to resume after power has been restored.

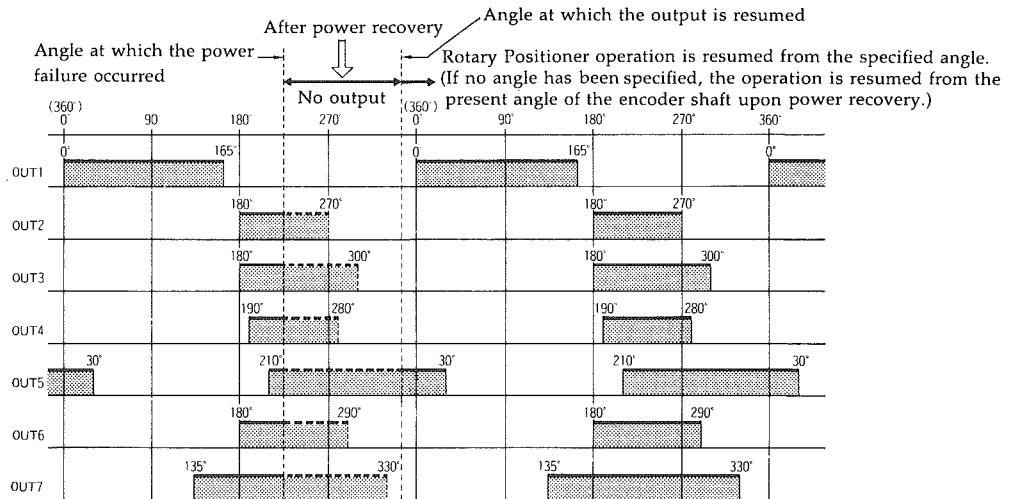
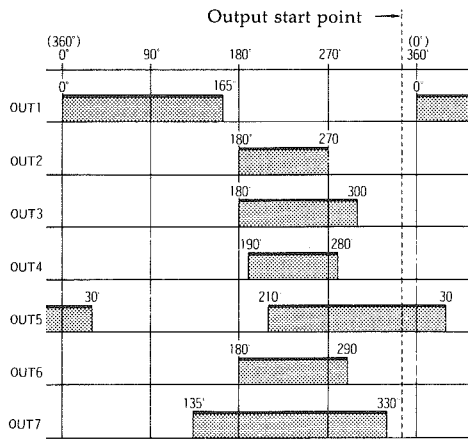

- (5) It is possible to set the revolution direction of the encoder shaft (to either clockwise or counterclockwise), even after the encoder has been installed.
- (6) The FORCED RUN input signal protects the program from being changed by mistake while the Rotary Positioner is executing it.
- (7) The INHIBIT input signal can turn OFF all the output signals during operation.

(8) To simplify the programming procedures, the Rotary Positioner incorporates these convenient functions:

- **Teaching function**

Values can be registered in the memory of the Rotary Positioner directly from the actual readings of the rotary encoder. Both the settings of the angles at which control outputs are to turn ON/OFF and of the origin can be carried out with the teaching function.

- **Copy function**

Position data registered by the previous operation is always called up as the tentative value for the next operation by pressing the Up or Down key. This speeds up keying operations when compiling your program.

- **Sorting function**

Each of the Rotary Positioner's outputs (8, 16, or 24 total outputs, depending on the model you have selected) can be activated repeatedly within the same program, up to a maximum of 10 times each. When programming activation and deactivation of multiple outputs, it is not necessary to enter the data in the order of the activation but they will be sorted automatically.

Section 2 Ratings and Characteristics

2-1 Available Types

Programmable control outputs	8 points		16 points		24 points	
Output configuration	NPN	PNP	NPN	PNP	NPN	PNP
Model	H8PR-8	H8PR-8P	H8PR-16	H8PR-16P	H8PR-24	H8PR-24P

2-2 Ratings

Supply voltage		100 to 240 VAC 50/60 Hz
Operating voltage range		90 to 110% of rated supply voltage
Power consumption		Approx. 10 W (240 VAC 50 Hz)
Input	Encoder input	Accepts input from E6F-AB3C-C rotary encoder Response time: 5 kHz (0.2 ms) at 833 rpm of encoder shaft Adjustable to 0.5, 1, 2, 3, 4, and 5 kHz With built-in error detection function
	INHIBIT	Is input via contacts or transistor (selectable) and turns OFF all control outputs Contact input: 20 ms of response time Solid-state input: 5 ms of response time
	FORCED RUN	Is input when FORCED RUN and 0 V (or -COM) terminals are short-circuited and protects program from being modified
Output		Open-collector transistor output 30 VDC 100 mA max. NPN: H8PR-8, -16, -24 PNP: H8PR-8P, -16P, -24P
	Control outputs	No. of points: 8 (OUT1 to OUT8) for H8PR-8(P)/16 (OUT1 to OUT16) for H8PR-16(P)/24 (OUT1 to OUT24) for H8PR-24(P)
	RUN	Turns ON in RUN mode and OFF in case of error
Controllable encoder shaft rotation angle		Can be set in units of 1° One control output can be programmed to turn ON/OFF up to 10 times
Encoder cable extension		30 m max.
Ambient operating temperature		-10° to 55°C
Ambient operating humidity		35 to 85% RH
Mounting style		Panel mounted
Coating		Light gray (Munsell 5Y 7/1)

* Refer to Appendix D (page 47) for details on E6F-AB3C-C rotary encoder.

2-3 Characteristics

Encoder revolutiondirection	Clockwise/counterclockwise (selectable)*
Encoder origin adjustment	-179° to 180°
Teaching function	Angles at which control outputs are to be turned ON/OFF and point of origin can be registered in memory directly from encoder
Output starting angle	Angle at which control outputs are to be turned ON/OFF can be set at any point on 0° to 359° arc.
Memory protection against power failure	0.01 s
Memory protection	10 years min. (at 25°)
Insulation resistance	100 MΩ min. (at 500 VDC) between current-carrying terminals and noncurrent-carrying portion, and between power circuit and control output circuit
Dielectric strength	1,500 VAC 50/60 Hz for 1 minute between current-carrying terminal and noncurrent-carrying portion, and between power circuit and control output circuit
Impulse withstand voltage	3 kV (between power portion) 4.5 kV (between current-carrying terminals and noncurrent-carrying terminals)
Noise immunity	Square-wave noise applied by noise simulator** ±1.2 kV (between power terminals) ±500 V (between input terminals)
Static electricity	8 kV (malfunction durability)
Vibration	Mechanical durability: 10 to 55 Hz, 0.75 mm double amplitude Malfunction durability: 10 to 55 Hz, 0.5 mm double amplitude
Shock	Mechanical durability: 300 m/s ² (approx. 30 G) Malfunction durability: 100 m/s ² (approx. 10 G)
Weight	Approx. 1.5 kg

* The encoder shaft revolution direction is registered in memory upon power reset. When the revolution direction has been changed by the selector switch, therefore, turn OFF the power once and then ON again.

** In addition to the above noise immunity test, an inductive load and relay oscillation noise tests were conducted.

2-4 Output Response Time

Response frequency of encoder	Output response time
5, 4 kHz	0.3 ms max.
3 kHz	0.35 ms max.
2 kHz	0.5 ms max.
1 kHz	1.1 ms max.
0.5 kHz	1.5 ms max.

2-5 Dimensions

H8PR-8(P), -16(P)

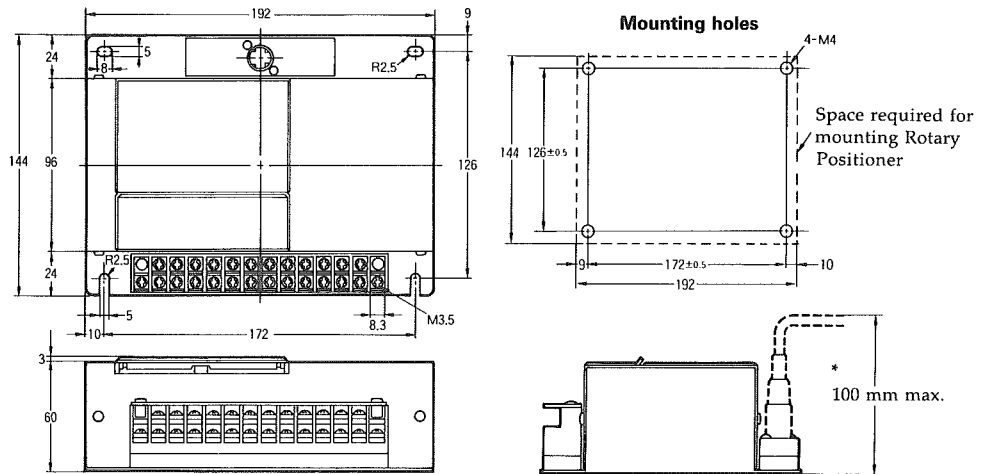

H8PR-24(P)

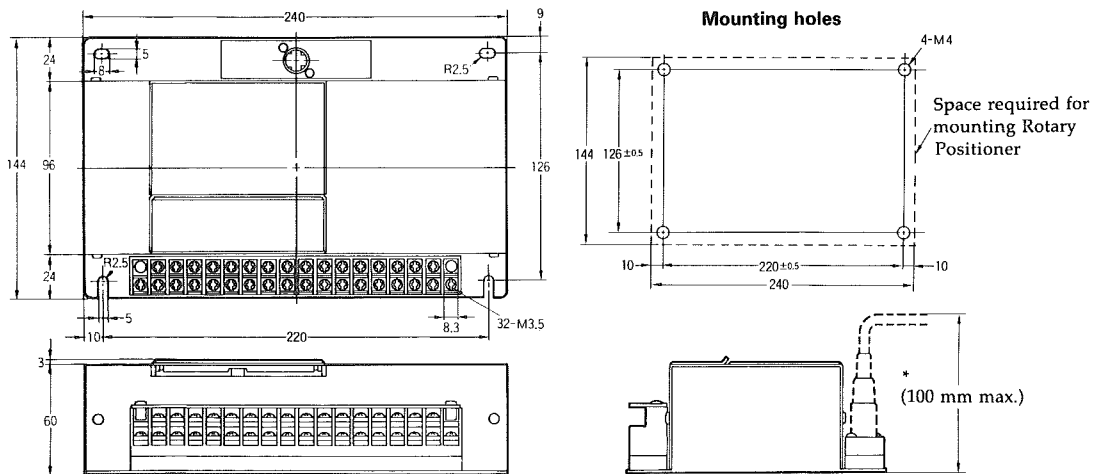

* See Appendix D (page 47 for information on the use of the OMRON E6F-AB3-C Rotary Encoder with the Rotary Positioner.

2-6 Connections

2-6-1 Input terminal arrangement

H8PR-8,-16

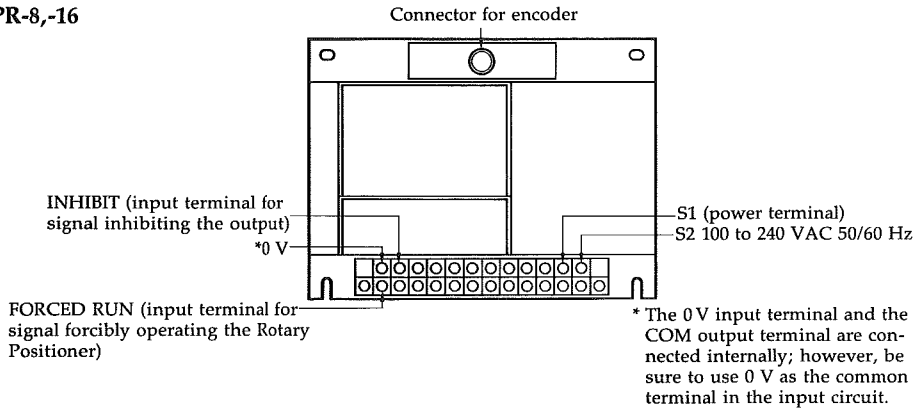

H8PR-24

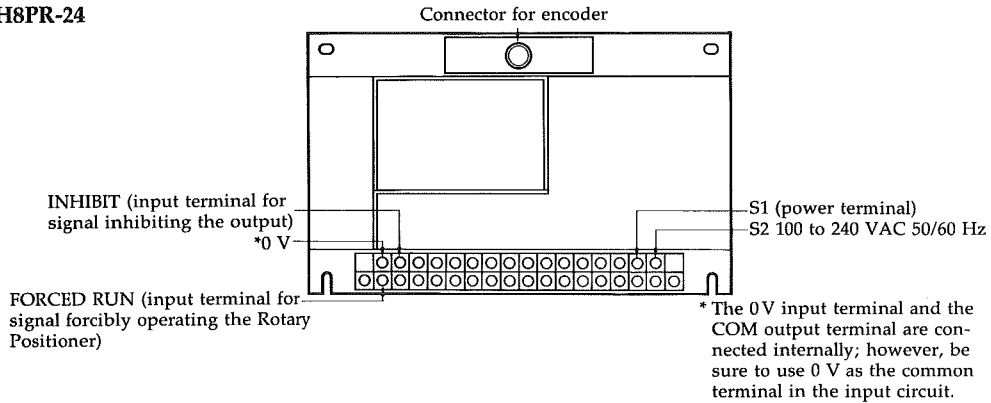

H8PR-8P, -16P

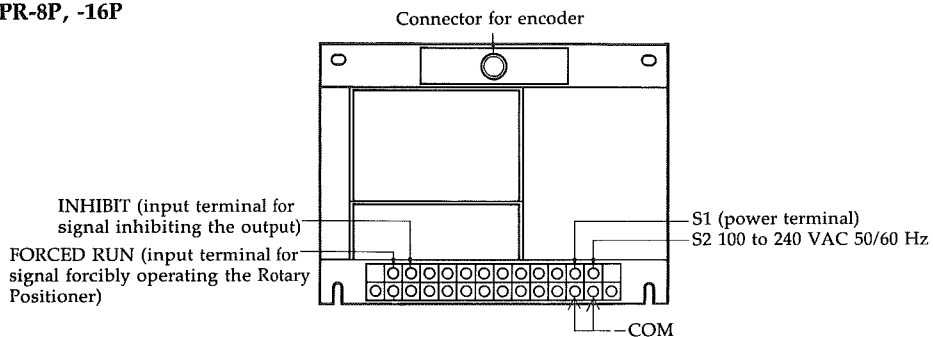

H8PR-24P

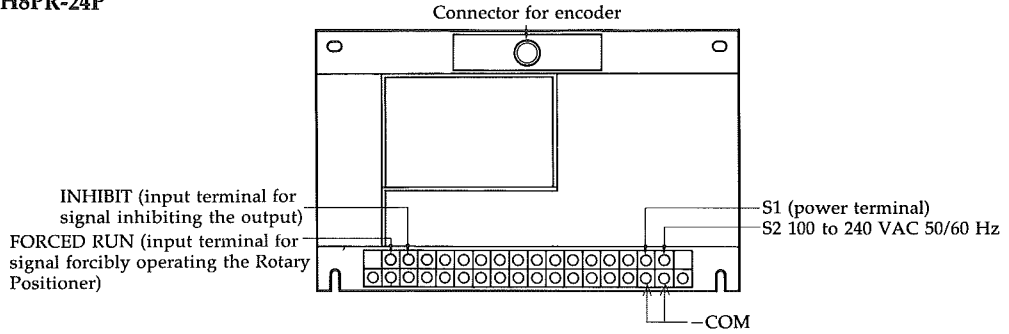

2-6-2 Encoder connection

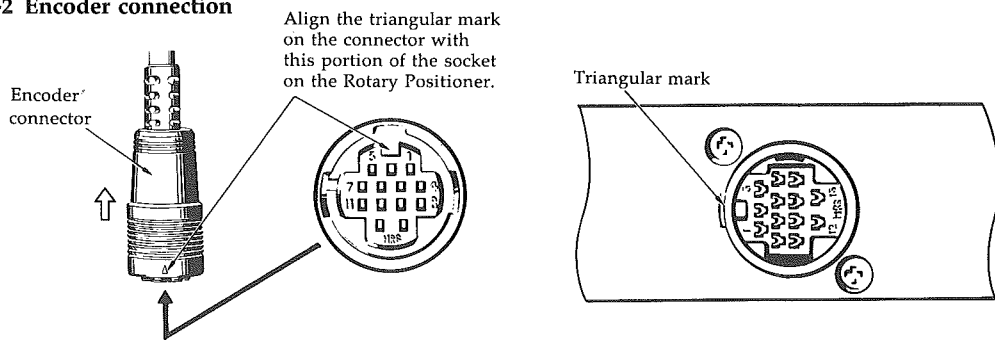

2-6-3 Connection of INHIBIT input

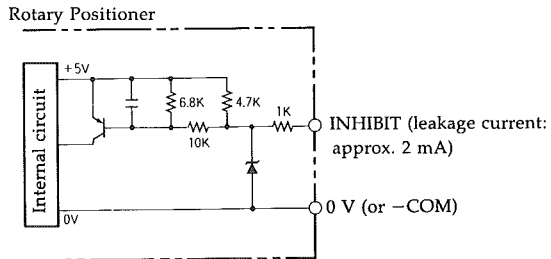

● **Contact input**

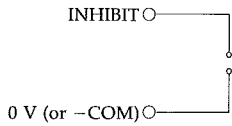

Resistance when contacts are closed: 1 kΩ max.
Resistance when contacts are opened: 100 kΩ min.

● **Solid-state/no-voltage input (open-collector)**

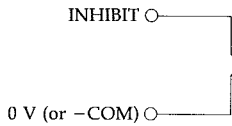

Residual voltage when transistor is ON: 2 V max. (source current from input terminals: approx. 2 mA)
Impedance when transistor is OFF: 100 kΩ min.
Note: The phase of the voltage input signal is reversed.

● **Solid-state no-voltage input**

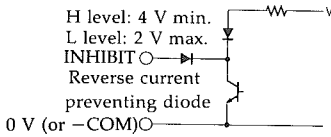

Residual voltage across input terminals when transistor is ON: 2 V max.
Impedance when transistor is OFF: 100 kΩ min.

2-6-4 Connection of FORCED RUN input

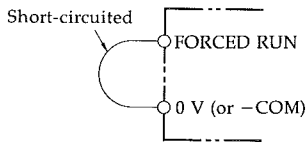

2-6-6 Connection of outputs

• Connection of relay

H8PR-8, -16, -24

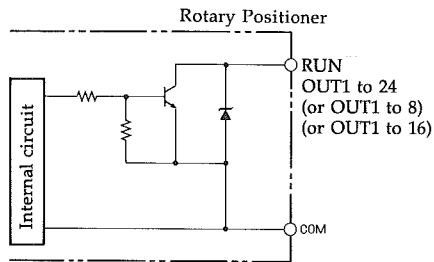

Output configuration	NPN, open-collector
Breakdown voltage	30 VDC
Load current	100 mA max.
Residual voltage	1.0 V max.
Leakage current	0.1 mA max.

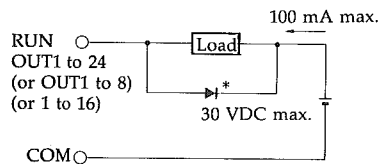

Note: Be sure to insert a diode to protect the output transistor from the counter electromotive force when an inductive load is connected.

H8PR-8P, -16P, -24P

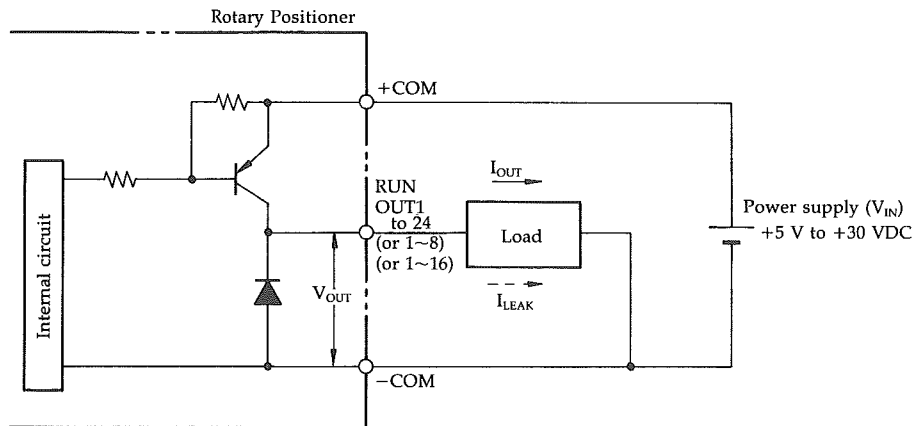

Output configuration	PNP open-collector
Supply voltage (V_{IN})	+5 V to +30 VDC
Output voltage (V_{OUT})	$(V_{IN} - 1.0 \text{ V})$ to V_{IN}
Load current (I_{OUT})	100 mA max.
Leakage current (I_{LEAK})	0.1 mA max.

● Connecting to programmable controller

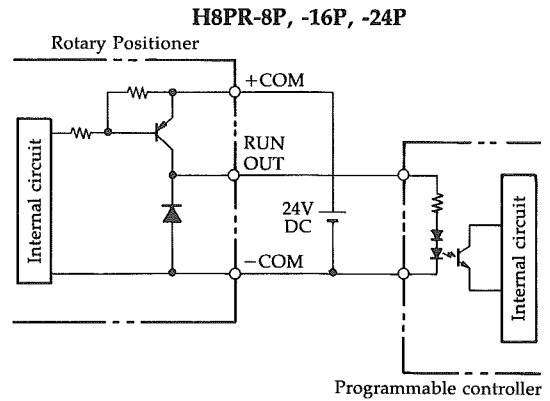
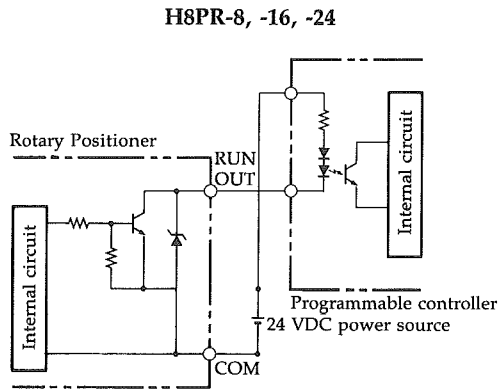

Note: Supply the power to the sensor for INHIBIT signal input and output circuit from the same power source.

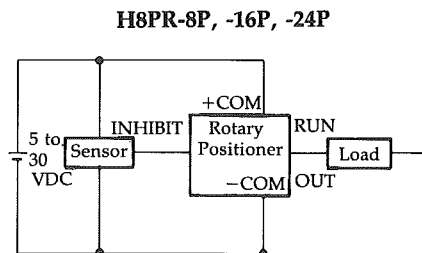
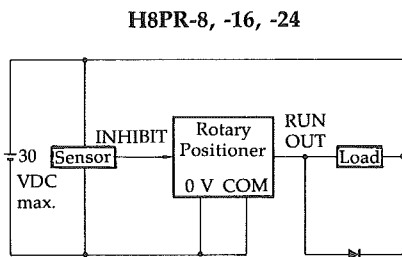

Section 3 Nomenclature and Settings

3-1 Nomenclature

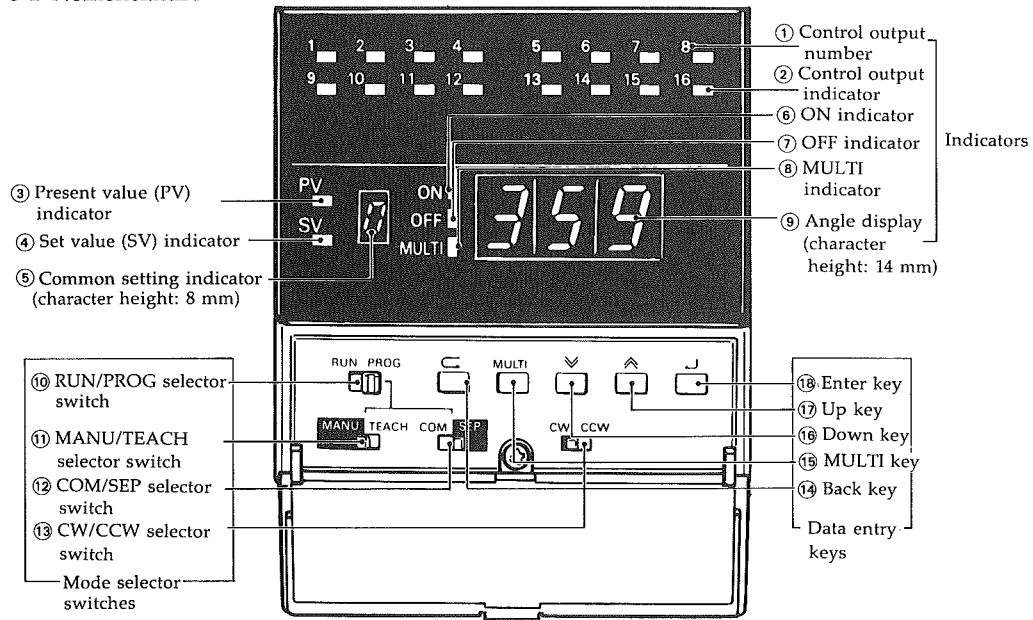













3-2 Indicators

Name	Function	
	RUN	PROG
① Control output numbers and control output indicators ②	By lighting up, identify the control output currently turned ON	By lighting up, identify the control output currently set
③ Present value (PV) indicator	Shows the present angle of encoder shaft	Goes off (but shows the present angle while setting of common setting A is being performed)
④ Set value (SV) indicator	Unlit	Indicates the displayed angle has been set.
⑤ Common setting indicator	Unlit	Indicates step numbers when programming control outputs to turn ON/OFF more than once.
		Indicates the character A, b, c, D, or E to identify the setting.
⑥ ON indicator	Unlit	Lights while the angle at which the control output should turn ON is being set.
⑦ OFF indicator	Unlit	Lights while the angle at which the control output should turn OFF is being set.
⑧ MULTI indicator	Unlit	Lights while the control output is being programmed to turn ON/OFF more than once.
⑨ Angle display	Displays the angles at which the control output should turn ON and OFF, the set common settings, and error messages.	











3-3 Selector Switches

- Mode selector switches

Name		Function	
⑩	RUN/PROG selector switch		Sets the RUN mode in which the Rotary Positioner operates.
			Sets the PROG mode in which the Rotary Positioner is programmed.
⑪	MANU/TEACH selector switch		Sets the MANU mode in which data are entered through key switches.
			Sets the TEACH mode in which the control output's ON/OFF angle and encoder shaft's point of origin are entered in memory directly from the encoder.
⑫	COM/SEP selector switch		Sets the SEP mode in which the ON and OFF angles can be set.
			Sets the COM mode in which common setting A, b, c, D, or E can be selected.
⑬	CW/CCW selector switch*		Causes the encoder shaft to rotate clockwise (when viewed from the shaft).
			Causes the encoder shaft to rotate counterclockwise (when viewed from the shaft).

* The encoder shaft's revolution direction specified by this switch becomes valid when power reset has been performed.

● Data entry keys

Name		Function	
⑭	Back key 		Returns the the step currently being set to the first step of the output or to output number 1.
			Returns the present common setting to the first parameter of the setting or to common setting A.
⑮	MULTI key 	Allows or cancels the function that programs the control output to turn ON/OFF more than once.	
⑯	Down key 		Decrements the angular data displayed on the indicator or the output number.
			Changes the setting of the common setting or shifts backward through the common settings from E to A.
⑰	Up key 		Increments the angular data displayed on the indicator or the output number.
			Changes the present common setting or shifts forward through the common settings from A to E.
⑱	Enter key 	Enters data in memory or increments the step.	

- A single press on the Up key or the Down key will increment or decrement the value on the indicator.
- Holding down either key will automatically increment or decrement angular data.
- Pressing one of the keys with the other held down will quickly increment or decrement the angular data. The effect of the key first pressed takes effect, however.
- The decrementing is stopped when the angular data has been decremented down to 0° and the incrementing is stopped when 359° has been reached. Pressing the Up or Down key again increments or decrements the data again.

Section 4 User Program

4-1 Separate Settings

Each control output can be programmed to turn ON or OFF at the required rotary encoder shaft angle. The following chart shows how each output is programmed to turn ON/OFF only once.

Model		Output No.	Step No. 0 and its data	
H8PR-8 H8PR-8P		OUT1	ON	(Angular data)
			OFF	(Angular data)
		OUT2	ON	(Angular data)
			OFF	(Angular data)
		OUT3	ON	Angular data)
			OFF	(Angular data)
		OUT4	ON	(Angular data)
			OFF	(Angular data)
OUT5	ON	(Angular data)		
	OFF	(Angular data)		
OUT6	ON	(Angular data)		
	OFF	(Angular data)		
OUT7	ON	(Angular data)		
	OFF	(Angular data)		
OUT8	ON	(Angular data)		
	OFF	(Angular data)		
OUT9	ON	(Angular data)		
	OFF	(Angular data)		
OUT10	ON	(Angular data)		
	OFF	(Angular data)		
OUT11	ON	(Angular data)		
	OFF	(Angular data)		
OUT12	ON	(Angular data)		
	OFF	(Angular data)		
OUT13	ON	(Angular data)		
	OFF	(Angular data)		
OUT14	ON	(Angular data)		
	OFF	(Angular data)		
OUT15	ON	(Angular data)		
	OFF	(Angular data)		
OUT16	ON	(Angular data)		
	OFF	(Angular data)		
OUT17	ON	(Angular data)		
	OFF	(Angular data)		
OUT18	ON	(Angular data)		
	OFF	(Angular data)		
OUT19	ON	(Angular data)		
	OFF	(Angular data)		
OUT20	ON	(Angular data)		
	OFF	(Angular data)		
OUT21	ON	(Angular data)		
	OFF	(Angular data)		
OUT22	ON	(Angular data)		
	OFF	(Angular data)		
OUT23	ON	(Angular data)		
	OFF	(Angular data)		
OUT24	ON	(Angular data)		
	OFF	(Angular data)		

Note: The angular data must be from 0 to 359°.

- Each control output can be programmed to turn ON/OFF up to 10 times. The following chart shows how this is done.

Model		Output No.		Step contents								
				0	1	2	3	4	5	6	7	8
H8PR-8, H8PR-8P	H8PR-16, H8PR-16P	OUT 1	ON	(Angular data)								
			OFF	(Angular data)								
		OUT 2	ON	(Angular data)								
			OFF	(Angular data)								
		OUT 3	ON	(Angular data)								
			OFF	(Angular data)								
		OUT 4	ON	(Angular data)								
			OFF	(Angular data)								
		OUT 5	ON	(Angular data)								
			OFF	(Angular data)								
		OUT 6	ON	(Angular data)								
			OFF	(Angular data)								
		OUT 7	ON	(Angular data)								
			OFF	(Angular data)								
		OUT 8	ON	(Angular data)								
			OFF	(Angular data)								
		OUT 9	ON	(Angular data)								
			OFF	(Angular data)								
		OUT 10	ON	(Angular data)								
			OFF	(Angular data)								
		OUT 11	ON	(Angular data)								
			OFF	(Angular data)								
		OUT 12	ON	(Angular data)								
			OFF	(Angular data)								
OUT 13	ON	(Angular data)										
	OFF	(Angular data)										
OUT 14	ON	(Angular data)										
	OFF	(Angular data)										
OUT 15	ON	(Angular data)										
	OFF	(Angular data)										
OUT 16	ON	(Angular data)										
	OFF	(Angular data)										
OUT 17	ON	(Angular data)										
	OFF	(Angular data)										
OUT 18	ON	(Angular data)										
	OFF	(Angular data)										
OUT 19	ON	(Angular data)										
	OFF	(Angular data)										
OUT 20	ON	(Angular data)										
	OFF	(Angular data)										
OUT 21	ON	(Angular data)										
	OFF	(Angular data)										
OUT 22	ON	(Angular data)										
	OFF	(Angular data)										
OUT 23	ON	(Angular data)										
	OFF	(Angular data)										
OUT 24	ON	(Angular data)										
	OFF	(Angular data)										

Note: The angular data must be from 0 to 359°.

4-2 Common Settings

Common setting	Function
A (point of origin adjustment)	<ul style="list-style-type: none"> Adjusts the present angle of the encoder shaft to 0° regardless of the actual angle. Sets the difference between the encoder shaft's present angle and 0° as the origin compensation angle. <p>When the present angle is 0° to 179°, $y = 0 - x$ where y is the compensation value and x is the present angle and when the present angle is 180° to 359°, $y = 360 - x$</p> <ul style="list-style-type: none"> (displayed angle) = (encoder shaft's present angle) + (origin compensation value) Set angle - 179° to +180°
b (output start angle)	<ul style="list-style-type: none"> Turns OFF the control outputs at power restoration when power failure occurs or when the RUN/PROG switch is moved from the RUN to PROG, and then back to RUN position. Sets an angle from 0° to 359°, or nothing.
C (encoder input speed)	<p>Selects the response frequency in accordance with the revolution speed of the encoder shaft.</p> <p>The following six response frequencies may be specified. 5 kHz (833 rpm)/ 4 kHz (666 rpm)/ 3 kHz (500 rpm)/ 2 kHz (333 rpm)/ 1 kHz (166 rpm)/ 0.5 kHz (83 rpm)</p>
E (output inhibit input filter)	<p>Selects the response speed of the INHIBIT input depending on whether the input signal is applied via contacts or a solid-state element (such as transistor). Two response speeds may be selected: 20 ms and 5 ms.</p>

4-3 Special Setting

Common setting	Function
d (memory all clear)	<ul style="list-style-type: none"> Erases all the data for the separate settings (ON/OFF angle). Erases all the memory contents.

Section 5 Program

The Rotary Positioner can be programmed in two ways: to enter data through the key switches on the front panel or using the teaching function.

5-1 Using Key Switches

First prepare a timing chart like the one shown below to determine the operation of each control output, i.e., determine at what angle of the encoder shaft each output must turn ON or OFF.

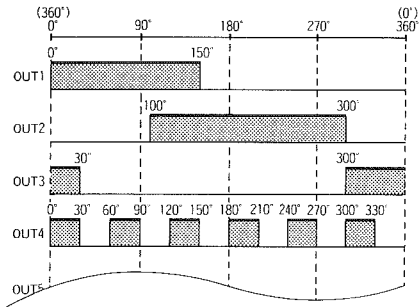

Based on the timing chart, prepare a list that shows the angular data of each program step.

Output number		Step number								
		0	1	2	3	4	5	6	7	8
OUT1	ON	0								
	OFF	150								
OUT2	ON	100								
	OFF	300								
OUT3	ON	300								
	OFF	30								
OUT4	ON	0	60	120	180	240	300			
	OFF	30	90	150	210	270	330			
OUT5	ON									
	OFF									
OUT6	ON									
	OFF									

● **Programming separate settings**

Next, enter the angular data for all the program steps through the key switches on the front panel. To do this, first set the three selector switches as follows:

RUN/PROG selector switch: PROG
 MANU/TEACH selector switch: MANU
 COM/SEP selector switch: SEP

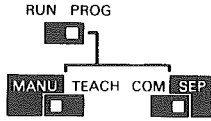

Initially, output indicator 1 blinks and setting indicator indicates 0.



Separate setting	Key operation	Indication	Remarks
ON angle of OUT1 (0°)		LED lights 1 ON SV OFF ON	The lowest digit position of the angle display blinks prompting you to enter the angle at which the control output 1 (OUT1) is to turn ON.
		1 SV OFF OFF	Enter the ON angle of OUT1 followed by pressing the Enter key. Then the lowest digit position of the angle display blinks again, this time prompting you to enter the next data.
OFF angle of OUT1 (150°)	Hold down the Up/Down key until the desired angle is set. The displayed value is incremented in units of 1° each time the key is pressed sharply. To increment the displayed value quickly, hold down the Up key and press the Down key. To decrement it quickly, hold down the Down key and press the Up key.	1 SV OFF OFF	The value displayed on the angle display blinks until the Enter key is pressed.
		2 SV OFF ON	Upon pressing the Enter key, the specified OFF angle is entered in memory and the lowest digit position of the angle display returns to 0 and blinks, prompting you to enter the next data.
ON angle of OUT2 (100°)	Hold down the Up/Down key until the desired angle is set. The displayed value is incremented in units of 1° each time the key is pressed sharply. To increment the displayed value quickly, hold down the Up key and press the Down key. To decrement it quickly, hold down the Down key and press the Up key.	2 SV OFF ON	The value displayed on the angle display blinks until the Enter key is pressed.
		2 SV OFF OFF	Upon pressing the Enter key, the specified ON angle is entered in memory and the lowest digit position of the angle display returns to 0 and blinks, prompting you to enter the next data.

Separate setting	Key operation	Indication	Remarks
OFF angle of OUT2 (300°)		2 ■ SV OFF	Press the Up key. The previous data, 100°, will be displayed again by the copy function. Hold down the Up key and press the Down key to set the OFF angle to 300°.
	$(\uparrow + \downarrow)$	2 ■ SV OFF	
ON angle of OUT3 (300°)		3 ■ SV ON	Press the Enter key. The lowest digit position of the angle display will return to 0 and blink, prompting you to enter the next data.
	$(\downarrow + \uparrow)$	3 ■ SV OFF	
OFF angle of OUT3 (30°)		3 ■ SV OFF	Pressing the Up key displays the data set for the preceding data and thus the angle 300° is displayed. Hold down the Up key and press the Down key to increment it to 30° via 360° which is the quicker route. The displayed value blinks until the Enter key is pressed.
	$(\uparrow + \downarrow)$	3 ■ SV OFF	
OFF angle of OUT3 (30°)		4 ■ SV ON	Press the Enter key. The lowest digit position of the angle display will return to 0 and blink, prompting you to enter the next data.
	$(\downarrow + \uparrow)$	4 ■ SV OFF	

● Factory Settings

A :

b :

c :

d :

E :

● Programming control outputs to operate more than once

Separate setting	Key operation	Indication	Remarks
Increasing the number of OUT4 operations		4 SV MULTI LED lights	Press the MULTI key. The lowest digit position of the angle display blinks, prompting you to enter the data for step 0 of OUT4.
ON angle of step 0 of OUT4 (0°)		4 SV MULTI	Enter the angle 0° in memory by pressing the Enter key. The lowest digit position of the angle display blinks, prompting you to enter the next data.
OFF angle of step 0 of OUT4 (30°)	 (+)	4 SV MULTI	Hold down the Up key and press the Down key until the angle 30° is set.
		4 SV MULTI	Press the Enter key. The lowest digit position of the angle display blinks, prompting you to enter the next data.
ON angle of step 1 of OUT4 (60°)	 (+)	4 SV MULTI 4 SV MULTI	Press the Up or Down key to display the data for the preceding step, 30° (copy function). Hold down the Up key and press the Down key until the angle 60° is set.
		4 SV MULTI	Press the Enter key. The lowest digit position of the angle display blinks, prompting you to enter the next data.
OFF angle of step 1 of OUT4	 (+)	4 SV MULTI 4 SV MULTI	Press the Up key to display the data for the preceding step, 60°. Hold down the Up key and press the Down key until the angle 90° is set.
		4 SV MULTI	Press the Enter key. The lowest digit position of the angle display blinks, prompting you to enter the next data.

Program the operation of rest of the control outputs in the same manner.

Cancellation of increasing the number of output operations		5 SV MULTI LED goes off	
--	--	-----------------------------	--

5-2 Preparing to Program Common Settings

Prior to programming the settings, set the selector switches on the front panel as follows:

RUN/PROG selector switch: PROG

MANU/TEACH selector switch: MANU

COM/SEP selector switch: COM

Note: To set the origin compensation value, it is necessary that the E6F-AB3C-C rotary encoder be attached to the machine to be controlled by Rotary Positioner.

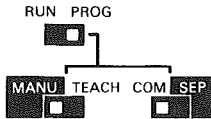



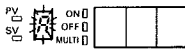











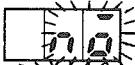





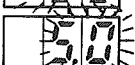





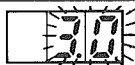





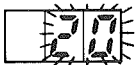

Initially, the setting indicator displays blinking character A.

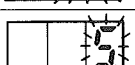

● Programming

Common setting	Key operation	Indication	Remarks
A (origin compensation)	If any data other than 0 is displayed on the angle display, set 0 by pressing the Up or Down key.	SV PV	
• Check the data presently in memory.)			(In this example, the reset angle of the encoder shaft is 24°.)
• Check the present angle of encoder shaft.*)			*This key operation is not necessary if you know the present angle of encoder shaft.
• Prepare for entering the compensation data.)		SV	(When the present angle is from 0° to 179°, $y = 0 - x$ where y is the compensation value, x is the present angle. When the present angle is 180° to 359°, $y = 360 - x$ In this case, the compensation value is $0 - 24 = -24$.)
• Enter the compensation data -24°.)		SV	
• Check the present angle of the encoder shaft after the origin has been corrected.)		PV	(By entering the compensation value -24°, the present angle of the encoder shaft is compensated to 0°.)

Common setting	Key operation	Indication	Remarks
b (output start angle)	  or  	        	<p>The angle display shows either the message "no" or a value from 0 to 359.</p> <p>(In this example, the control output is programmed to start operating at an encoder shaft angle of 100°.)</p> <p>Enter 100°.</p>
C (encoder input speed)	 or  	     	<p>(In this example, the encoder input speed is set to 3.0 kHz.)</p> <p>Enter 3.0 kHz.</p>
d (memory all clear)		  	<p>Refer to the description of the special function on page 26.</p>
E (INHIBIT input filter)	 or  	     	<p>(In this example, the INHIBIT input filter is set to 5 ms.)</p> <p>Enter 5 ms. (The angle display returns to common setting A.)</p>

5-3 Changing and Checking Program

After the program is entered in memory, it can be changed or checked as required regardless of whether it has been entered through the key switches or by the teaching function.

• Separate settings

To check the separate settings, first set the selector switches as follows:

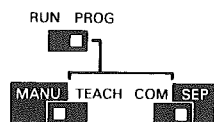

RUN/PROG selector switch: PROG
 MANU/TEACH selector switch: MANU
 COM/STEP selector switch: SEP

Initial indication



• Program checking and changing operations

Item	Key operation	Indication	Remarks
Selection of output number to be changed	or 	 	<p>In this example, the settings of OUT4 are changed. Press the MULTI key if the MULTI indicator blinks.</p> <p>The data for the step 0 of OUT4 is displayed.</p>
Changing ON/OFF angle	Same key operation as programming	Same indication of the ON/OFF angle as programming.	
Changing program	 	<p>(The changed data will be displayed hereafter.)</p>	<p>In this example, the data in step 0 of OUT4 is changed into 5°.</p> <p>The data in the steps of OUT4 are sequentially displayed.</p>
(To return to OUT1)	 	 	<p>The data in step 0 of OUT4 is displayed.</p> <p>The data in step 0 of OUT1 is displayed.</p>
Checking program		(The program in the memory is displayed sequentially.)	

Note: Adding data when increasing the number of output operations

		Step No. 0
OUT (n)	ON angle	245
	OFF angle	260

Data addition

		Step No. 0	Step No. 1	Step No. 2
OUT (n)	ON angle	245	130	15
	OFF angle	260	135	25

If data have been added as shown above, they are automatically rearranged as follows (sorting function):

		Step No. 0	Step No. 1	Step No. 2
OUT (n)	ON angle	15	130	245
	OFF angle	25	135	260

Timing chart

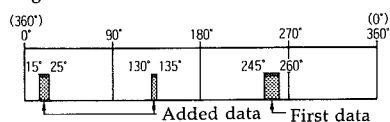

• Common settings

To change or check the common settings, first set the selector switches as follows:

RUN/PROG selector switch: PROG

MANU/TEACH selector switch: MANU



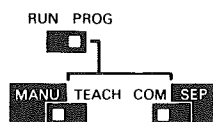

COM/SEP selector switch: COM

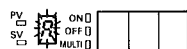

(Initial indication)

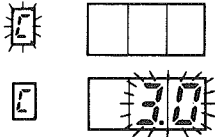

• Changing and checking common settings

Common setting	Key operation	Indication	Remarks
Selection of data to be changed	 or  		<p>In this example, common setting C that sets the encoder input speed is changed.</p> <p>The presently set value (3.0 kHz in this example) is displayed.</p>
Changing setting	Same key operation as programming	(Same indication as when programming common settings)	
Checking program		(The program in memory is sequentially displayed.)	

5-4 Special Setting

● Memory all clear

This function erases the ON and OFF angles of all the control outputs entered in memory through key switches or by the teaching function. To execute Memory All Clear function, set the selector switch as follows:

RUN/PROG selector switch: PROG





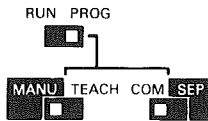



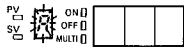

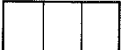

MANU/TEACH selector switch: MANU

COM/SEP selector switch: COM



Initial indication



Common setting	Key operation	Indication	Remarks
d (memory all clear)	 or 	 	Special setting d that clears all the memory contents is specified.
		 	If the memory contents should not be cleared, press the Enter key when the message "no" appears on the angle display.
	 or 	 	If the memory contents should be cleared, press the Enter key when the message "CLr" appears on the angle display.
		 	When the memory contents have been cleared, the data of common setting E (20 or 5) is displayed.

5-5 Specifying Encoder Shaft Revolution Direction

The direction in which the encoder shaft is to revolve can be specified by the CW/CCW selector switch on the front panel.



Connect the encoder to the machine to be controlled by the Rotary Positioner. Determine whether a change in the direction is necessary by the values shown in the Rotary Positioner's display.

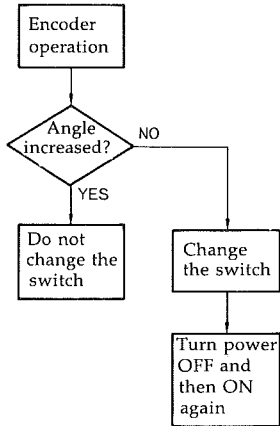

5-6 Programming with Teaching Function

The teaching function can be used to program the control output operation and origin compensation value. (In programming common settings, set all the data except for the origin compensation value through the key switches.)

Before using the teaching function, connect the E6F-AB3C-C rotary encoder to the machine to be controlled and perform the connection between the encoder and Rotary Positioner.

• Preparing for origin compensation teaching

Before executing the teaching function to automatically set the origin compensation value, set the selector switches on the front panel as follows:

RUN/PROG selector switch: PROG

MANU/TEACH selector switch: TEACH



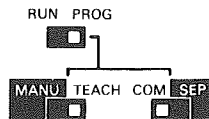

COM/SEP selector switch: COM

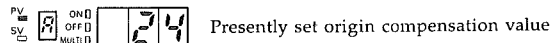

Initial indication

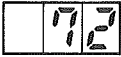

● Execution of teaching function

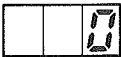
Common setting	Key operation	Indication	Remarks
A (origin compensation value)		<p>PV  </p> <p>PV  </p>	<p>In this example, the origin compensation value is 72° after the origin setting of the Rotary Encoder.</p> <p>The origin compensation value is entered in memory automatically when the Enter key is pressed.</p>

● Preparing to program separate settings by teaching function

To program the separate settings using the teaching function, set the selector switches as follows:

RUN/PROG selector switch: PROG

MANU/TEACH selector switch: TEACH

COM/SEP selector switch: SEP

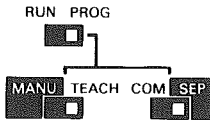

Initial indication











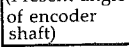

The characters "tch" standing for "teach" are displayed.

The data for all the control outputs are set by the teaching function sequentially, starting from OUT1. It is also possible to set the data for only the specified control output. Moreover, the teaching function can be used regardless of whether the output is to be turned ON/OFF only one time or more.

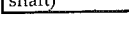
● Execution of teaching function

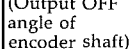
The ON and OFF angles of the control outputs are sequentially set by the teaching function, starting from OUT1.

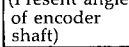





















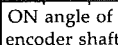

Setting	Key operation	Indication	Remarks
Sequential setting of ON and OFF angles from OUT1		1 ■ PV  ON 	(In this example, it is assumed that the setting of OUT1 is completed and the present angle of encoder shaft is at 80°.) *Manually operate the machine to be controlled (i.e., rotate the encoder shaft) to program the ON and OFF angles of the control outputs by the teaching function.
ON angle of OUT1		1 ■ PV  ON  (Output ON angle of encoder shaft)	Rotate the encoder shaft to the position at which the control output should turn ON.
OFF angle of OUT1		1 ■ PV  OFF  (Present angle of encoder shaft)	Enter the ON angle by pressing the Enter key. (The data is entered in memory at the moment the Enter key is released.)
OFF angle of OUT1		1 ■ PV  OFF  (Output OFF angle of encoder shaft)	Rotate the encoder shaft to the position at when the control output should turn OFF.
OFF angle of OUT1		2 ■ PV  ON  (Present angle of encoder shaft)	Enter the OFF angle by pressing the Enter key. (The data is entered in memory at the moment the Enter key is released.*)

(Program rest of the outputs in the same manner as key switch programming.)

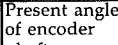
Note: To cancel the data after the Enter key has been pressed, press the Up or Down key without releasing the Enter key.

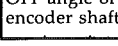
● Execution of teaching function



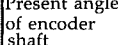



Set the data for the specified output as follows:

Item	Key operation	Indication	Remarks
Selection of OUT No.	 or 	 PV  ON <input type="checkbox"/> OFF <input type="checkbox"/> MULTI <input type="checkbox"/> 	(In this example, OUT7 is selected.)
		 PV  ON <input type="checkbox"/> OFF <input type="checkbox"/> MULTI <input type="checkbox"/> 	
ON angle of OUT7		 PV  ON <input checked="" type="checkbox"/> OFF <input type="checkbox"/> MULTI <input type="checkbox"/> 	Preparation for the setting of OUT7 is completed. (In this example, the present angle of the encoder shaft is 100°.)
		 PV  ON <input type="checkbox"/> OFF <input checked="" type="checkbox"/> MULTI <input type="checkbox"/> 	(Rotate the encoder shaft to the position at which the OUT7 should turn ON.)
OFF angle of OUT7		 PV  ON <input type="checkbox"/> OFF <input checked="" type="checkbox"/> MULTI <input type="checkbox"/> 	Enter the ON angle in memory by pressing the Enter key.
		 PV  ON <input checked="" type="checkbox"/> OFF <input type="checkbox"/> MULTI <input type="checkbox"/> 	(Rotate the encoder shaft to the position at which the OUT7 should turn OFF.)
		 PV  ON <input type="checkbox"/> OFF <input type="checkbox"/> MULTI <input checked="" type="checkbox"/> 	Enter the OFF angle in memory by pressing the Enter key.

(Program rest of the outputs in the same manner as key switch programming.)

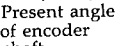
● Execution of teaching function

The teaching function can also be used to increase the number of output operations.

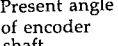
Item	Key operation	Indication	Remarks
Increasing the number of OUT1 operations		 PV  ON <input checked="" type="checkbox"/> OFF <input type="checkbox"/> MULTI <input type="checkbox"/> 	
		 PV  ON <input type="checkbox"/> OFF <input type="checkbox"/> MULTI <input checked="" type="checkbox"/> 	

(Program rest of the outputs in the same manner as key switch programming.)

Section 6 RUN

After setting all the data, move the RUN/PROG selector switch to the RUN position to set the RUN mode in which the program is executed.

6-1 Changing Program during Execution

“Switching the RUN/PROG selector switch from RUN to PROG, and back to RUN, during operation produces the effect illustrated below.”

The operations of the control outputs before and after the change differ depending on the output start angle set by common setting b.

6-1-1 Changing ON/OFF angle

If no output start angle is set as the parameter of common setting b

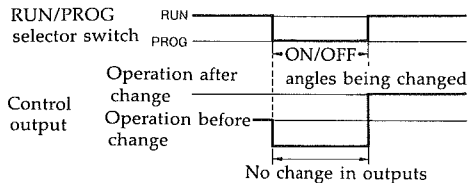

If the output start angle is set to 0° to 359°

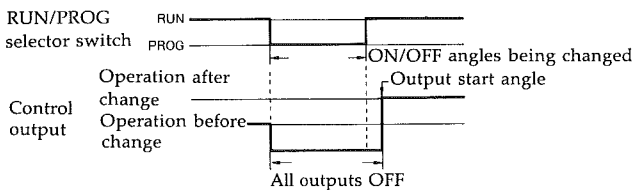

6-1-2 Changing output start angle

If the output start angle is changed from the previous setting of “no” to 0° to 359°

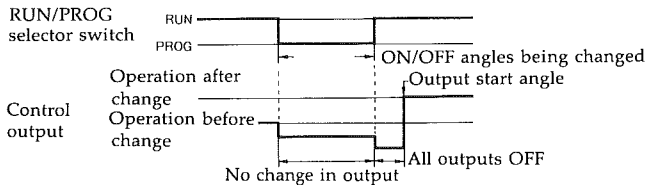

If the output start angle is changed from the previous setting of 0° to 359°, to “no”

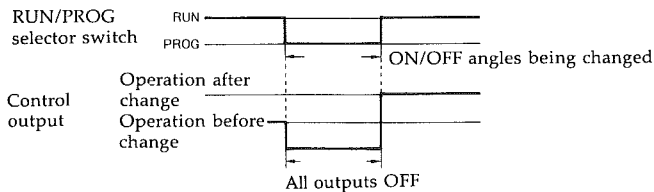

6-2 Control Outputs on Power Recovery

The Rotary Positioner allows you to set the output restart angle at which, if a power failure has occurred, the control outputs' operations are resumed on power recovery.

The operations of the control outputs differ depending on whether the power failure has occurred while the program was being executed or while the control outputs were being programmed.

6-2-1 If Power failure occurs during program execution

If no output start angle is set as the parameter of common setting b

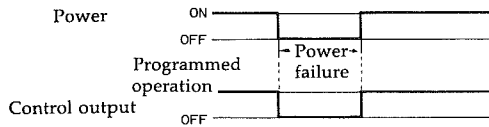

If the output start angle is set to 0° to 359°

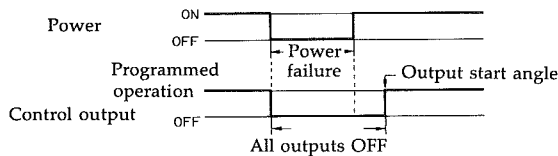

6-2-2 If power failure occurs during programming

If no output start angle is set as the parameter of common setting b

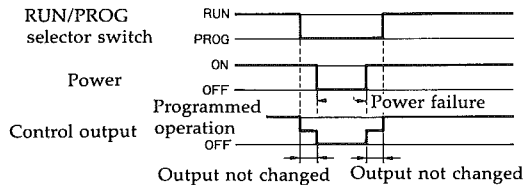

If the output start angle is set to 0° to 359°

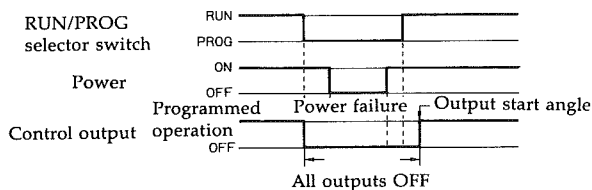

Note: If a power failure occurs while the setting of the output start angle is being changed, the control outputs operate as follows upon power recovery.

If the output start angle is changed from the previous setting of "no" to 0° to 359°

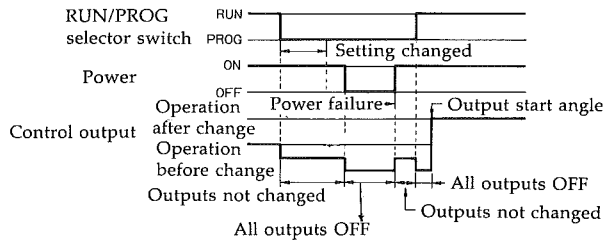

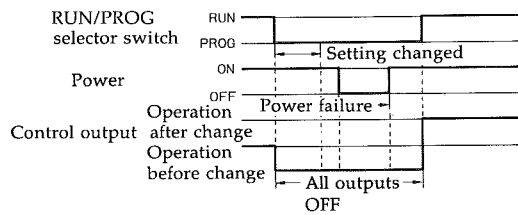

If the output start angle is changed from the previous setting of 0° to 359°, to "no"



Appendix

Appendix A Error Messages

● Error Messages and remedies

Error message	Cause	Remedy
	Indicates a change in the program (checksum error). This message may be displayed in the RUN mode, either while operations are in progress or on power recovery.	Set the RUN/PROG selector switch from the RUN to the PROG position, correct the data that has caused the error, and then switch back to the RUN position.
	Indicates an error in the encoder input: (1) indicates input of an abnormal data (other than 0° to 359°) (displayed in the RUN/PROG mode) (2) Indicates disconnection of the encoder connector or jump of angle in the RUN mode. (displayed in the RUN mode only) (3) Indicates that the encoder revolution speed has exceeded the response limit (displayed in the RUN mode only). In any of above case (1) to (3), all the control outputs are shut OFF. "E2" indication is retained in the RUN mode.	Set the RUN/PROG selector switch to the RUN position the followings at the PROG position. (1) Abnormality of the encoder (2) Incorrect connection of the encoder connection (3) Settings of the encoder revolution speed and response speed (4) Noise and surge protections
	Displayed in the PROG mode and indicates the memory area of the program that has caused an "E1" error in the RUN mode.	Correct the data that has caused the error, using the Up or Down key and enter the corrections with the Enter key.

Note: Errors "E1" and "E2" will cause all the control outputs to be shut OFF.

Appendix B Precautions

- Turn ON or OFF the power to the Rotary Positioner abruptly, using the contacts of such a device as a switch or relay.
- A warm-up time of approximately 1~4 second is required after turning the power ON.

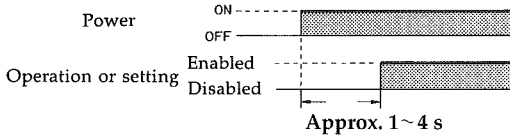

- Multiple ON/OFF angles should not overlap for a control output. If overlapping angles were inadvertently specified, the ON and OFF indicators will blink. Reprogram as necessary.

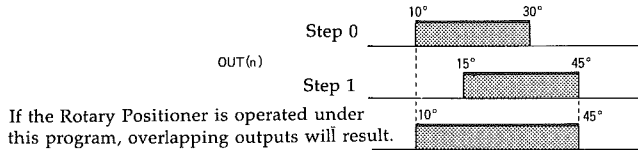

- Confirm that both the ON and OFF angles have been correctly entered for all the outputs specified in your program.
- If only the ON angle has been specified, for example, the OFF angle will be assumed to be 360° (0°) as shown below.

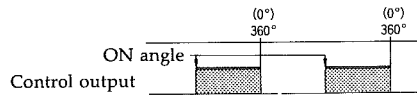

- Likewise, if only the OFF angle is specified, the ON angle will be assumed to be 0°.
- When changing the ON/OFF angle, if only the ON angle is changed with the OFF angle left as is, the results are as follows:

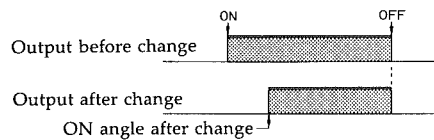

- Conversely, if only the OFF angle is changed with the ON angle left as is, the results are as follows:

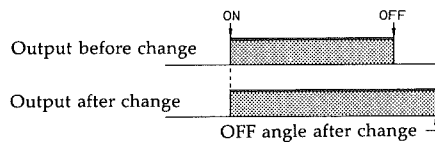

- Should both the ON and OFF angles for a particular output be mistakenly assigned the same value, no output will occur.
- The RUN output is not produced in the PROG mode.

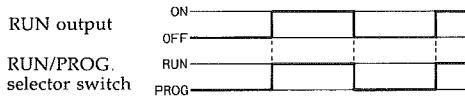

- Multiple outputs can be applied in parallel to the load as shown below (OUT1 to 8 for the H8PR-8(P), OUT1 to 16 for H8PR-16(P), OUT1 to 24 for H8PR-24(P)).

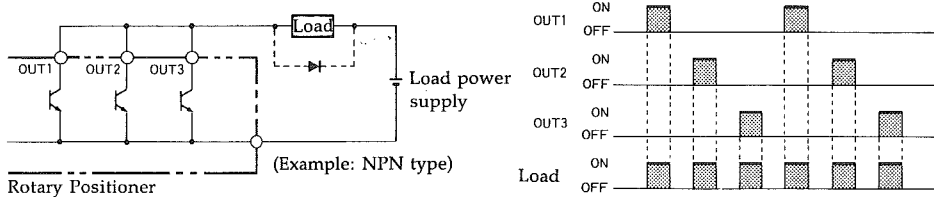

- If the INHIBIT input signal is turned ON, all the control outputs are shut OFF.
- If the FORCED RUN input signal is turned ON, i.e., when the FORCED RUN terminal is short-circuited to the 0 V terminal, the Rotary Positioner is forcibly set in the RUN mode and all the settings and programming are disabled, regardless of the statuses of the selector switches.
- Do not loosen any of the screws on the front panel nor attempt to detach the display or keys from the Rotary Positioner.
- The metal housing of the Rotary Positioner and the neutral point of the internal circuit are internally short-circuited and thus, the housing may charge electricity. Therefore, be sure to ground the FG terminal to prevent electric shock.
- To measure dielectric strength, impulse withstand voltage, or insulation resistance between the electric circuitry and noncurrent-carrying metal parts of the Rotary Positioner with the Rotary Positioner incorporated in a control panel, disconnect all the wirings from the Rotary Positioner. (This is because, if the dielectric strength or insulation of devices in the control panel degrades, the test voltage may be applied across the power terminals of the Rotary Positioner, causing degradation of or damage to the Rotary Positioner's internal circuit.)
- When using the Rotary Positioner at a location where much noise is generated, separate the Rotary Positioner and its input device and input lines from the noise source and power lines.

- The coating of the Rotary Positioner's housing is not resistant to organic solvents (thinner, benzine), strong alkalis(ammonia, caustic soda), and strong acid substances.
- Do not use the Rotary Positioner at a location subject to corrosive gases, water or oil splash, or direct sunlight.
- Do not use the Rotary Positioner at a location subject to shock or vibration.
- Do not remove the outer housing.
- When using the Rotary Positioner in an environment where static electricity is frequently charged (e.g., where molding materials, particles, or fluid substances are transported through pipes), keep the Rotary Positioner at an adequate distance from the source of the static electricity.
- Store the Rotary Positioner at a temperature of -25°C to 65°C . If the Rotary Positioner has been stored at -10°C or below, leave it at room temperature for three hours or longer, before use.
- An impulse voltage test was conducted in conformance with JEC-212, by applying 3 kV standard waveform between the power terminals. Moreover, noise test was conducted, using a noise simulator, by applying 1.2 kV noise having a pulse width of 100 ns and a rise time of 1 ns. If the Rotary Positioner is used where noises exceeding the above values may be generated, use a surge absorber.
- **The Rotary Positioner contains a lithium battery, and must never be incinerated.**

Appendix C Coding Sheet

C-1 Timing Chart

(H8PR-8(P): OUT1 to 8, H8PR-16(P): OUT1 to 16, H8PR-24(P): OUT1 to 24)

Output No.	Name of load	(360°)				(0°)
		0°	90°	180°	270°	360°
OUT1	()					
OUT2	()					
OUT3	()					
OUT4	()					
OUT5	()					
OUT6	()					
OUT7	()					
OUT8	()					
OUT9	()					
OUT10	()					
OUT11	()					
OUT12	()					
OUT13	()					
OUT14	()					
OUT15	()					
OUT16	()					
OUT17	()					
OUT18	()					
OUT19	()					
OUT20	()					
OUT21	()					
OUT22	()					
OUT23	()					
OUT24	()					

Output start angle °

C-2 Coding Sheet

● Separate settings

(H8PR-8(P): OUT1 to 8, H8PR-16(P): OUT1 to 16, H8PR-24(P): OUT1 to 24)

Write the ON/OFF angle of the control output in step 0 when the MULTI key is not used.

Output No.	MULTI key used?	ON/OFF angle	Step No.											
			0	1	2	3	4	5	6	7	8	9		
OUT1		ON angle												
		OFF angle												
OUT2		ON angle												
		OFF angle												
OUT3		ON angle												
		OFF angle												
OUT4		ON angle												
		OFF angle												
OUT5		ON angle												
		OFF angle												
OUT6		ON angle												
		OFF angle												
OUT7		ON angle												
		OFF angle												
OUT8		ON angle												
		OFF angle												
OUT9		ON angle												
		OFF angle												
OUT10		ON angle												
		OFF angle												
OUT12		ON angle												
		OFF angle												
OUT13		ON angle												
		OFF angle												
OUT14		ON angle												
		OFF angle												
OUT15		ON angle												
		OFF angle												
OUT16		ON angle												
		OFF angle												
OUT17		ON angle												
		OFF angle												
OUT18		ON angle												
		OFF angle												
OUT19		ON angle												
		OFF angle												
OUT20		ON angle												
		OFF angle												
OUT21		ON angle												
		OFF angle												
OUT22		ON angle												
		OFF angle												
OUT23		ON angle												
		OFF angle												
OUT24		ON angle												
		OFF angle												

● **Common setting**

A (\overline{A})	Origin compensation value	<input type="text"/>	°
B ($\rightarrow b : \overline{b}$)	Output start angle	<input type="text"/>	°
C (\overline{C})	Encoder input speed	<input type="text"/>	KHz
E (\overline{E})	Output inhibit filter	<input type="text"/>	ms

Appendix D Absolute Rotary Encoder E6F-AB3C-C

D-1 Features

The main features of the Absolute Rotary Encoder E6F-AB3C-C are described below.

- Durable and reliable absolute rotary encoder
- Detects arcs of 1° on a full circle of 360°
- Heavy-duty shaft withstands loads of up to 10 kg (radial) and 3 kg (axial). Shaft diameter: 10 mm; shaft length: 20 mm
- Employs optical detection system with a durable metal disk. No danger of disk damage due to shock
- Drip-proof, oil-resistant construction (meets IEC IP52F) permits versatile use in adverse environment
- Allows the shaft and driving system to be adjusted after connection
- Equipped with oil-proof insulated cord
- Provided with connecting socket for use of 20 mm diameter conduit

D-2 Ratings/Characteristics

Supply voltage	5 to 12 VDC-5%, +10%, ripple(p-p): 5% max.
Current consumption	100 mA max.
Detecting method	Absolute type
Resolution (per rev.)	360 (10 bits)
Output code	BCD
Output configuration	Open-collector transistor output
Output power ratings	Applied voltage: 30 VDC max. Sink current: 35 mA max. Residual voltage: 0.4 V max. (at 35 mA sink current)
Maximum response frequency*	10 kHz
Logic	Negative (H level: 0, L level: 1)
Accuracy	±0.5° max.
Revolution direction	Output code increases in clockwise direction (when viewed from shaft)
Output rise and fall times	1.0 μs max. (control output voltage: 5 V, load resistance: 470 Ω, output cable: 2 m max.) 2.0 μs max. (control output voltage: 5 V, load resistance: 1 kΩ, output cable: 2 m max.)
Starting torque	100 g-cm max.
Moment of inertia	15 g-cm ²
Shaft loading	Radial: 10 kg, Axial: 3 kg
Maximum number of revolutions	5,000 rpm
Ambient temperature	Operating: -10 to 70° Storage: -25 to 80°
Ambient humidity	35 to 85% RH (without condensation)
Vibration	Mechanical durability: 10 to 55 Hz, 1.5 mm double amplitude (in X, Y, and Z directions, respectively for 2 hours)
Shock	Mechanical durability: 100 G (in X, Y, and Z directions, respectively 3 times)
Degree of protection	IEC IP52F (dust-proof, drip-proof)
Weight	Approx. 500 g (including 2-m cable)

* The maximum number of revolution the Rotary Positioner can electrically follow up is dependent on the revolution and maximum response frequency and is obtained by this formula.

$$\text{Electrical maximum number of revolutions (rpm)} = \frac{\text{Maximum response frequency} \times 60}{\text{Revolution}}$$

If the encoder shaft revolves more than the maximum number of revolutions, its signal cannot electrically follow up.

D-3 Output Stage Circuit Diagram

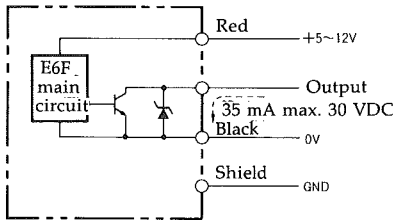

- * This circuit configuration applies to all the outputs.
- ** The outer core of the shielded wire is neither connected internally nor to the housing.
- *** Normally connect the GND terminal to the 0 V potential or ground.

Terminal No.	Terminal Name
1	Output 2 ⁰
2	Output 2 ¹
3	Output 2 ²
4	Output 2 ³
5	Output 2 ⁰ ×10
6	Output 2 ¹ ×10
7	Output 2 ² ×10
8	Output 2 ³ ×10
9	Output 2 ⁰ ×100
10	Output 2 ¹ ×100
11	GND
12	5 to 12 V power
13	0 V (COMMON)

D-4 Output Mode

Revolution direction: clockwise (viewed from shaft)

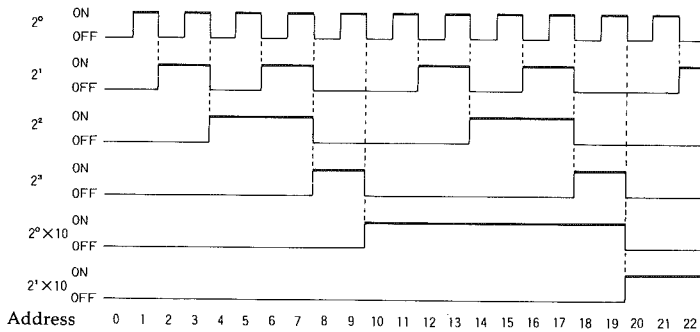

D-5 Dimensions

E6F-AB3C-C

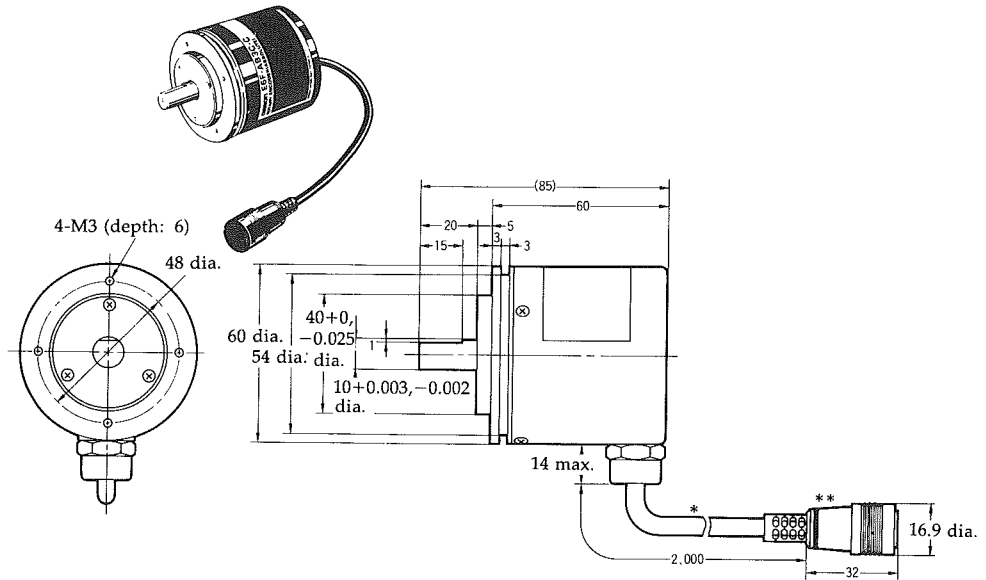

* Oil-proof vinyl-insulated, round shielded cable (outer dia.: 6, 12/7/0.18 dia., standard length: 2 m)

** Rotary positioner connector

D-6 Accessories

Mounting bracket (included)

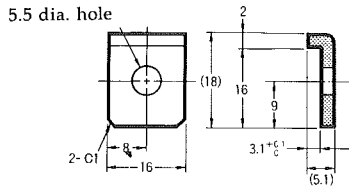

Coupling E69-C10B (order separately)

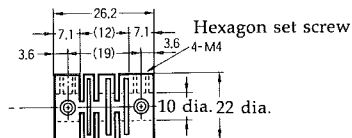

Note: 1. Material: glass-reinforced polyacetal resin (GC-25)
 2. Screw clamping torque: 4.5 kg-cm
 3. Heat resistivity: 100°C

With mounting brackets

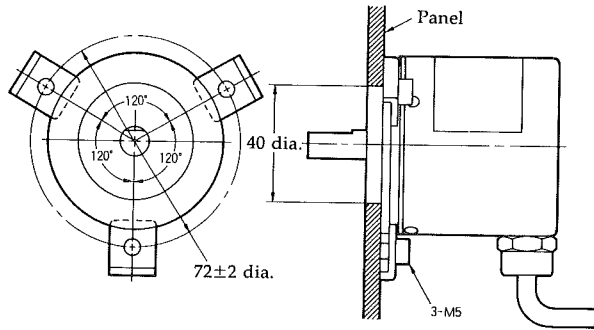

D-7 Connector Pin Layout

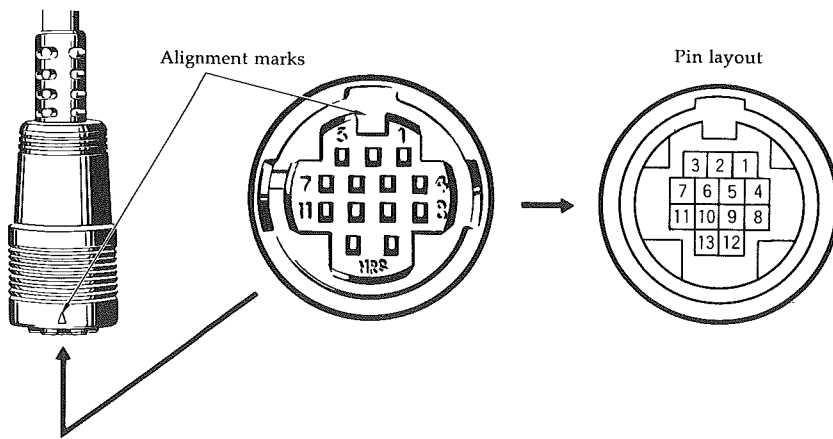

D-8 Precautions

- Although the degree of protection of the drip-proof, oil-proof rotary encoder meets IP52F, degradation of the encoder characteristics is accelerated if the encoder is subjected to constant splash of water or oil.

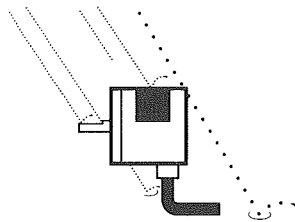

- Make sure that the shaft coupling is centered. Serial off-centering of the shaft coupling will cause rapid deterioration in performance and accuracy cannot be guaranteed.

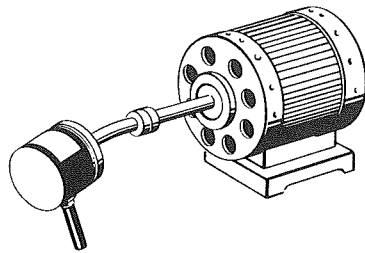

- Do not subject the encoder shaft to unnecessary shock. This can cause serious damage to the shaft bearing.

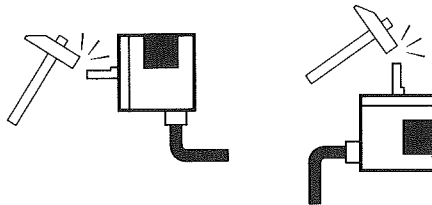

- Do not remove the protective cover. If foreign matter adheres to the internal disk of the encoder, the encoder cannot output the correct signals.
- Do not subject the base of the cable to unnecessary strain or stretching.



OMRON Corporation

Industrial Automation Company

Measuring and Supervisory Controls Department

Shiokoji Horikawa, Shimogyo-ku,

Kyoto, 600-8530 Japan

Tel: (81) 75-344-7108/Fax: (81) 75-344-7189

In the interest of product improvement, specifications are subject to change without notice.

Authorized distributor: