

i4-650H/750H/850H

High performance robot for assembly, material handling, and precision machining.

- Integrated Control with EtherCAT connectivity or Standard Control with Ethernet connectivity.
- At-a-glance robot status with highly visible, multi-colored LED light ring and LCD display.
- Reach Options of 650 mm, 750 mm, 850 mm with 210 mm or 410 mm z-axis stroke.
- IP65, Electrostatic Discharge (ESD) protection, Cleanroom, and Food Grade models available.



Ordering Information

RS4-20□□□□□□

1 2 3 4 5 6

Item	Description	Details	Designation
1	Robot Type	SCARA	RS4-20
2	Control Type	Standard Control	5
		Integrated Control*1	6
3	Reach	650 mm	6
		750 mm	7
		850 mm	8
4	Mount Configuration	Standard	5
		Inverted	7
5	Protection Rating / Feature	IP20 with standard lubrication	0
		IP20 with Food Grade lubrication	5
		IP65 with Food Grade lubrication	4
		Cleanroom / ESD	1
6	Z-axis Quill Stroke Length	210 mm (IP20 with standard lubrication / IP65)	2
		210 mm (IP20 with Food Grade lubrication)	3
		410 mm (IP20 with standard lubrication / IP65)	4
		410 mm (IP20 with Food Grade lubrication)	5

*1 Some first-generation models do not support TIO and integrated pneumatic valve control. Contact your local OMRON representative for more information.

i4H-Series

System Configuration

Typical system configurations are shown below. Other equipment and connections are possible.

Integrated Control

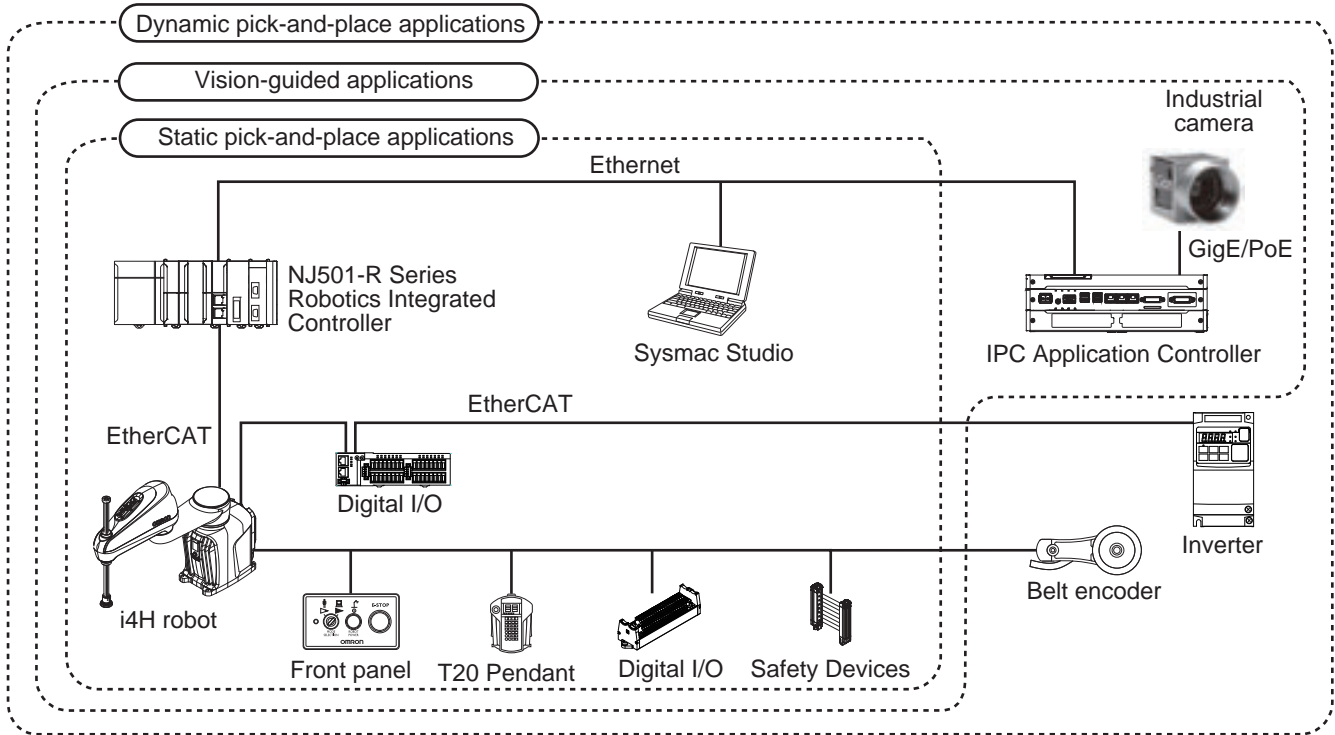

Standard Control

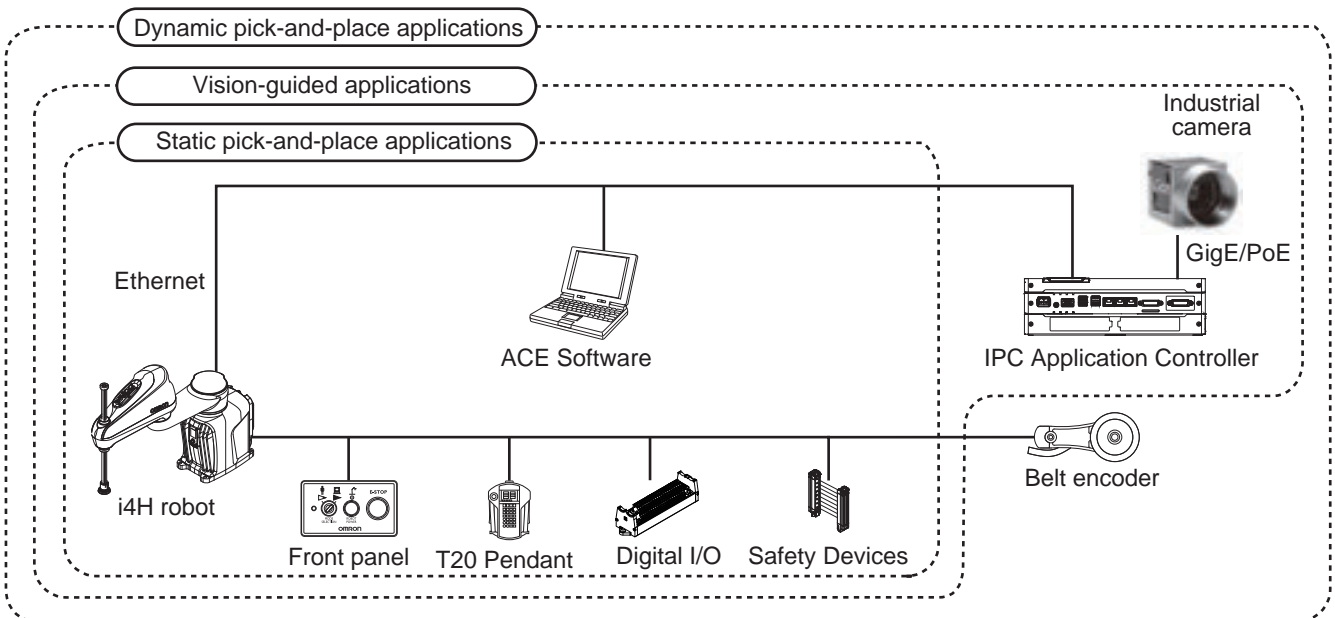

Specifications

Product		i4-650H		i4-750H		i4-850H	
Quill Length		210 mm	410 mm	210 mm	410 mm	210 mm	410 mm
Number of Axes		4					
Reach		650 mm		750 mm		850 mm	
Maximum Payload*1		15 kg					
Repeatability at 100% speed	XY	±0.015 mm					
	Joint 3	±0.01 mm					
	Joint 4	±0.005°					
Joint Range	Joint 1	±152°					
	Joint 2	±140°					
	Joint 3	210 mm (Standard Quill), 410 mm (Long Quill)					
	Joint 4	±360°					
Inertia Moment (Max.)	Joint 4	0.5 kg·m ²					
Maximum push force - downward, no load*2	Joint 3	588 N					
Joint Speeds	Joint 1	450 deg/s					
	Joint 2	720 deg/s					
	Joint 3	1583 mm/s					
	Joint 4	2400 deg/s					
Cycle Times*3,*4	Burst*5	0.41 s		0.39 s		0.39 s	
	Sustained	0.45 s		0.46 s		0.50 s	
	Blended Burst*5	0.32 s		0.31 s		0.31 s	
Power Requirements	DC	24 VDC ±10%, 8 A max.					
	AC	200 to 240 VAC, 50/60 Hz, Single Phase, 12.0 A max.					
Protection	IP20	IP20 / NEMA Type 1					
	IP65	IP65 / NEMA Type 4, Food Grade Lubrication NSF H1, ISO 21469 certified					
	Food Grade	NEMA Type 1, Food Grade Lubrication NSF H1, ISO 21469 certified					
	Electrostatic Discharge	Conductive and grounded external surfaces					
	Cleanroom	ISO 4 / Class 10					
Mounting	Table, Inverted, Wall						
Environment Requirements	Ambient Temperature	0° to 40°C					
	Humidity Range	5% to 90% non-condensing					
Weight	IP20 Models	50.4 kg	50.8 kg	50.9 kg	51.3 kg	51.6 kg	52.0 kg
	IP65 / Cleanroom Models	52.9 kg	53.3 kg	53.4 kg	53.8 kg	54.1 kg	54.5 kg
On-board I/O	Inputs	12 Sinking / Sourcing (XIO), 5 Sinking (TIO), 0 to 30 VDC					
	Outputs	12 Sourcing, 24 VDC ±10%, 0.7 A per output 1.5 A max. @ 25°C for all circuits					
Tool network connection (Ethernet / EtherCAT)		1 (4 pin, M12 female)					
Electrical pass-through ports		2 (19 pin, M23 male)					
Pneumatic ports		8 (6 mm, push-type fittings) max. pressure 0.55 MPa					
Vacuum ports (Cleanroom Models)		2 (10 mm push-type fittings) 0.14 m ³ /minute min., 81 mm water vacuum					
Belt Encoder		2 line driver inputs (A, B, and Z)					
RS-232C serial communication ports		1 (troubleshooting information only)					
Programming Software		Sysmac Studio / ACE Version 4*6					
IPC Application Manager		Robot Vision Manager, PackManager					
Controller		NJ501-R Series (Integrated Control robots only)					

*1 Payload includes any object(s) attached to a robot link or tool flange, including end-effectors, tooling, valves, grippers, and objects being handled by the robot.

*2 At a duty cycle of 3 seconds pushing and then 2 seconds not pushing.

*3 Cycle times may increase by up to 15% when operating in ambient temperatures above 20° C.

*4 Cycle time is defined as a continuous path with straight-line motion in which the robot tool moves up 25 mm, laterally 305 mm, down 25 mm, and then back along the same path (not achievable over all paths in the robot working envelope). Values listed are with no joint 4 rotation, at 20°C ambient with a 2.0 kg payload. Blended Burst cycle uses the same criteria with arc motion.

*5 Burst and Blended Burst cycle times may increase by up to 15% when bellows are present.

*6 Use Sysmac Studio for Integrated Control robots. Use ACE Version 4 for Standard Control robots.

i4H-Series

Options and Additional Items

Item	Description	Details	Part Number
XSYSTEM Cable with jumpers	Provides connections for a Front Panel, Teach Pendant, and other user-supplied devices.	1.8 m cable length.	13323-100 ^{*1}
Cable Seal Kit	Cable Seal for all cable connections at the Primary Interface Panel.	All components for replacing or installing a cable seal included.	08765-000 ^{*2}
Cable Seal Kit (Inverted Mount)			08765-200 ^{*2}
High Power Connector	Used to supply 200 to 240 VAC power for the internal servo amplifiers.	Includes connector, pins, and retaining clip.	22822-100 ^{*1}
Control Power Connector	Used to supply 24 VDC control power.	Includes connector and pins.	22822-200 ^{*1}
XBELTIO Cable	Provides connections to Belt Encoder, EXPIO, and RS-232 signals.	0.6 m cable length.	13463-000
XIO Breakout Cable	Provides a flying leads connection to digital I/O at the XIO connector on the robot.	5 m cable length.	04465-000
XIO Termination Block and Cable	Provides terminal block digital I/O connections at the XIO connector on the robot.	Includes a terminal block with a 1.8 m cable.	90356-40100
IO Blox Kit	Provides additional I/O (8 inputs and 8 outputs).	Includes an IO Blox unit with a 0.3 m cable.	90356-30200
IO Blox Expansion Kit	Provides IO Blox unit expansion.	Includes an IO Blox unit with a 0.3 m cable.	90356-30100
IO Blox Connection Cable	Connects two IO Blox units.	3 m cable length.	04679-030
	Connects an IO Blox unit and a robot.	3 m cable length.	04677-030
Encoder Kit	Includes all equipment to add an encoder to a robot.	Includes encoder, mounting bracket, and 5 m cable.	09742-001
TIO Connector Cable	Provides connections to Tool I/O signals.	1.8 m cable length.	19140-000
USER Connector Cable	Used for end-effector control and sensing.	1.8 m cable length.	18823-100
Encoder Extension Cable	Replaces or extends the Encoder Kit cable.	5 m cable length.	09446-050
Pneumatic Valve Kit	Provides three robot-controlled pneumatic valves.	All components included.	19165-000
Belt Encoder Y-adapter Cable	Provides two M12 connectors for the Belt Encoder signals/connector on the XSYSTEM cable.	3 m cable length.	09443-000
Electrical Pass-through Ports Cable	Provides flying leads for USER ports on the Primary and Secondary Interface Panels.	1.7 m cable length.	18823-100
Front Panel Kit	Remote mounted device for robot mode, power, indication, and emergency stop.	Includes a Front Panel with a 3 m cable.	92546-10358 ^{*1}
eCobra Mount Adapter	Adapts i4H robot mounting holes to the eCobra mounting hole pattern.		21636-000
eCobra Tool Flange	eCobra tool flange compatible with the i4H robot.		19106-100
Tool Flange (ISO)	Replacement i4H tool flange.		19106-000F
Camera Mounting Bracket	Used to mount a camera to the outer link.		18908-000
Camera Mounting Adapter	Provides Basler and Sentech camera mounting for the Camera Mounting Bracket.		22295-000
T20 Pendant Kit	Provides all required equipment for the T20 Pendant.	Includes the T20 Pendant, 3 m adapter cable, and an M23 jumper plug.	10046-010
IPC Application Controller	Used to execute PackManager and Robot Vision Manager applications.		AC1-152000
Wall Mount Bracket	Enables mounting the robot to a vertical surface.	Not compatible with IP65-rated robots.	20089-000
NJ501-R Series Robotics Integrated Controller	Machine controller with sequence, motion, and robotics functionality.	Refer to Cat. No. P140 for more information.	NJ501-R□□□
Sysmac Studio	Settings and creation of programs to control a robot with the Robot Integrated CPU Unit and IPC Application Controller.	A license for the Standard Edition (SYSMAC-SE201L) is required.	SYSMAC-SE200D-64
3D Simulation	Perform 3D simulation including robots and peripheral devices.		SYSMAC-SA401L-64
PackManager	Enables full functionality of the PackManager software.		20409-000
Robot Vision Manager	Enables the Robot Vision Manager functionality and inspection tools library.		20410-000
PackManager + Robot Vision Manager	Enables functionality of both PackManager and Robot Vision Manager		20433-000
Bellows Installation Kit	Two bellows and associated hardware for protecting the quill.	210 mm quill length.	19464-003F ^{*3}
Bellows Installation Kit		410 mm quill length.	19464-004F ^{*3}
Bellows Replacement Kit	Upper and lower replacement bellows.	210 mm quill length.	19464-103F
Bellows Replacement Kit		410 mm quill length.	19464-104F
Encoder Backup Battery Pack	Includes two 3.6 V batteries.		19238-000F ^{*1}

*1 Equipment supplied with all robots.

*2 Additional equipment supplied with IP65 rated robots.

*3 Additional equipment supplied with IP65 and Cleanroom / ESD rated robots.

Interface Panels

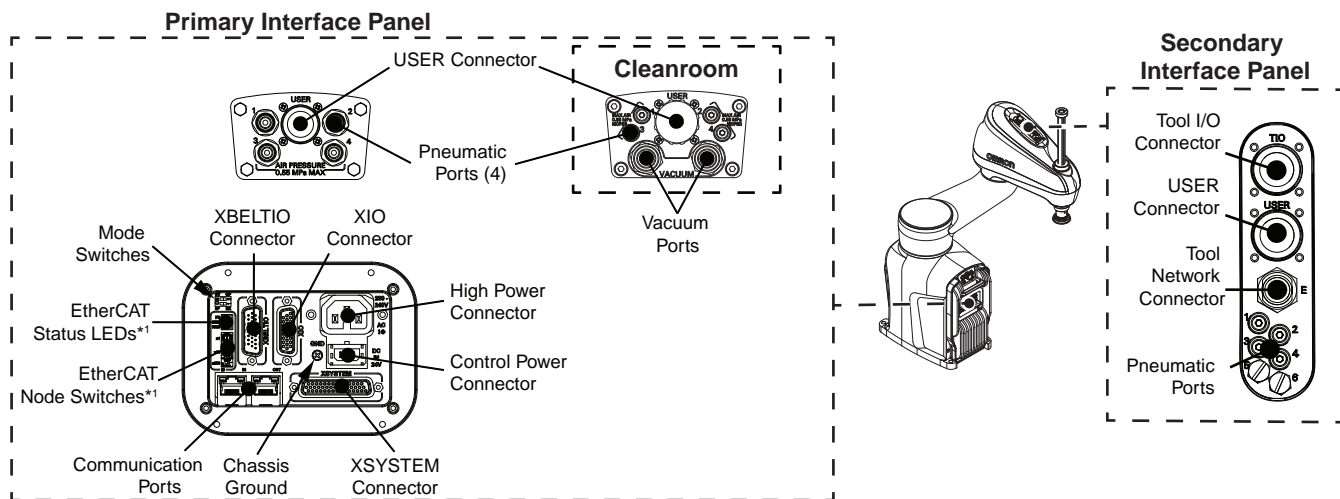

*1 Unused with Standard Control robots.

Cables and Connections

Refer to Options and Additional Items for more information.

Standard Cables and Connections

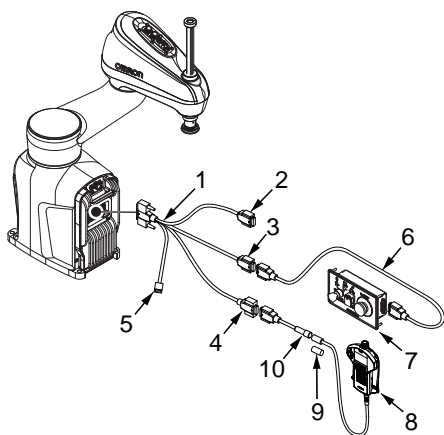

Item	Description	Function	Part Number
1	XSYSTEM Cable	Main interface cable.	13322-100
2	XUSR Connector	User-supplied safety devices.	
3	XFP Connector	Front Panel connections.	
4	XMCP Connector	T20 Pendant.	
5	Ethernet Connector	Service mode connection.	92546-10358
6	Front Panel Extension Cable		
7	Front Panel	High-power, mode, and E-stop.	
8	T20 Pendant		10046-010
9	T20 Pendant Jumper Plug	Used when T20 Pendant is not connected.	
10	T20 Pendant Adapter Cable		

Optional Cables and Connections

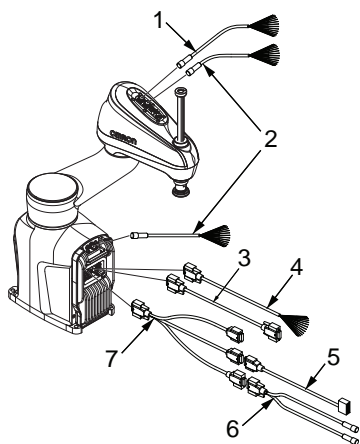

Item	Description	Function	Part Number
1	TIO Cable	On-board I/O to devices on outer link / tool flange.	19140-000
2	USER Connector Cables	Pass-through electrical signals.	18823-100
3	XIO Termination Block Cable	Connection to I/O termination block.	03695-000
4	XIO Breakout Cable	I/O flying leads.	04465-000
5	EXPIO to IO Blox Cable	IO Blox connections.	04677-030
6	Belt Encoder Y-adapter Cable	Direct encoder connections.	09443-000
7	XBELTIO Adapter Cable	Encoder, force, and RS-232 signal interface cable.	13463-000

i4H-Series

Mounting Options

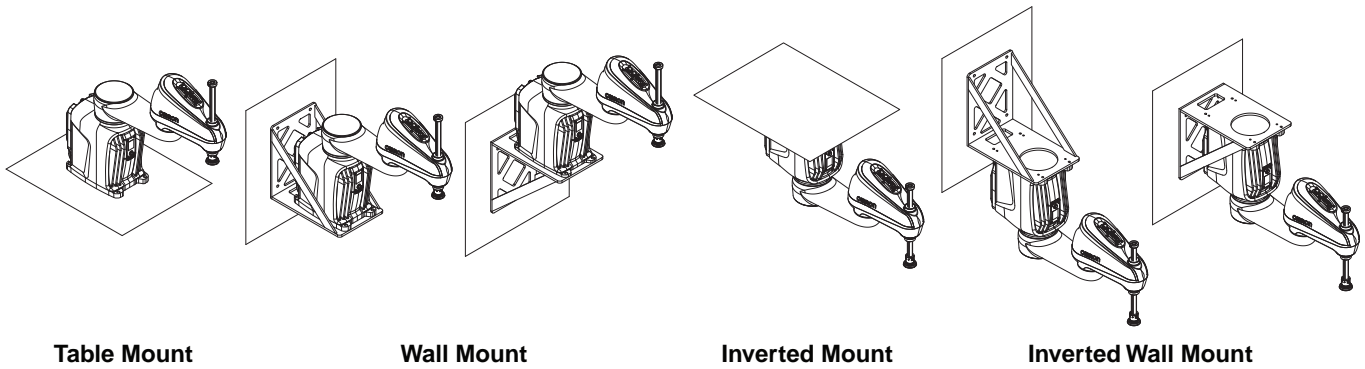

Table Mount

Wall Mount

Inverted Mount

Inverted Wall Mount

Robot Dimensions

(Unit: mm)

i4-650H

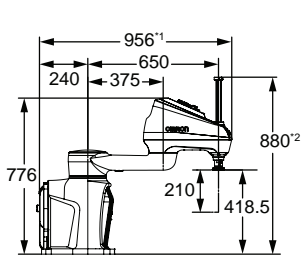

i4-650H Long Quill

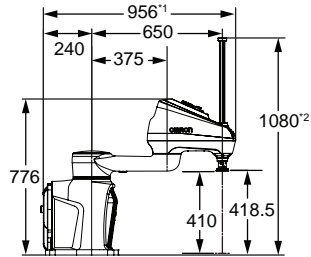

i4-650H Inverted

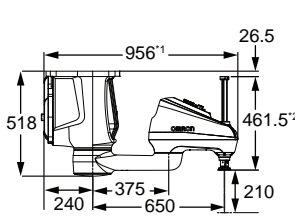

i4-650H Inverted, Long Quill

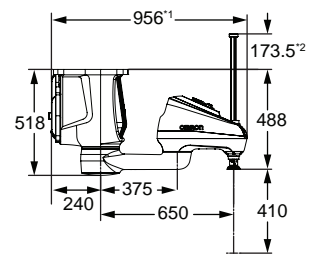

i4-750H

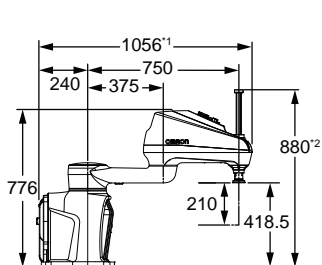

i4-750H Long Quill

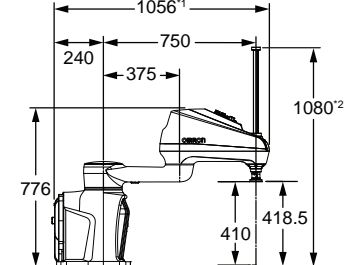

i4-750H Inverted

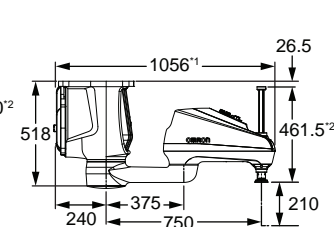

i4-750H Inverted, Long Quill

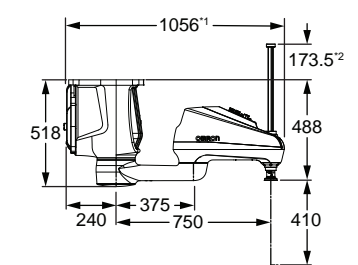

i4-850H

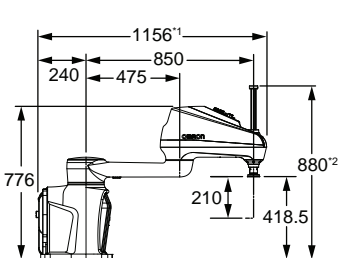

i4-850H Long Quill

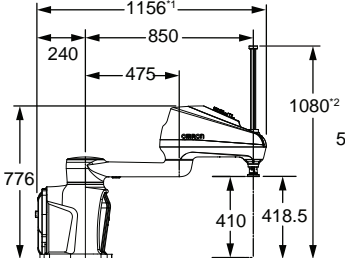

i4-850H Inverted

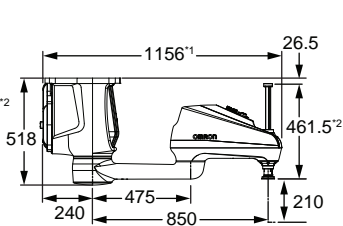

i4-850H Inverted, Long Quill

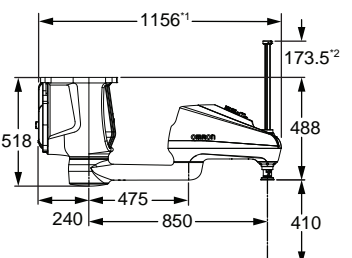

*1 For any model with a cable seal, this distance increases by 150 mm.

*2 For any model with bellows, this distance increases by 47 mm.

Note: The base of the robot is 240 mm wide.

Arm Reach Dimensions

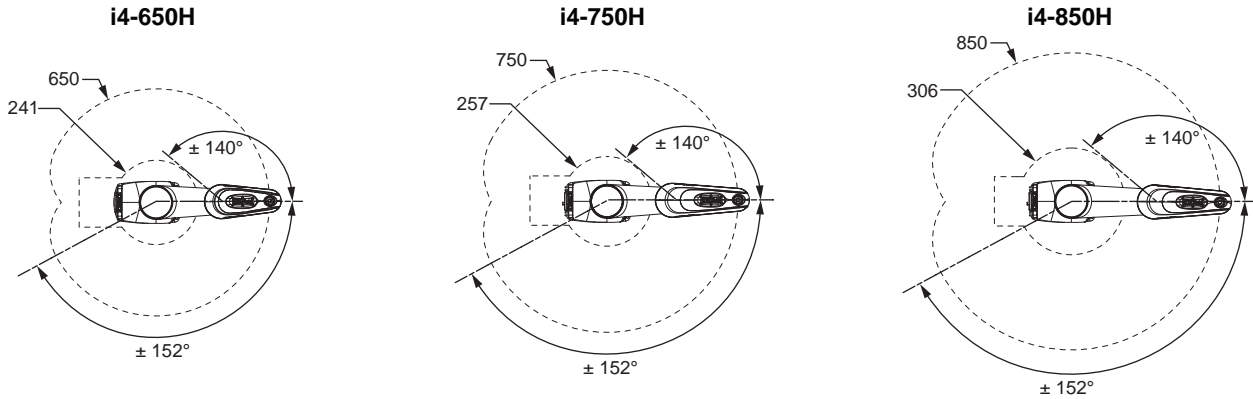

Note: Reach restrictions behind the robot may vary based on robot configuration and type.

Other Dimensions

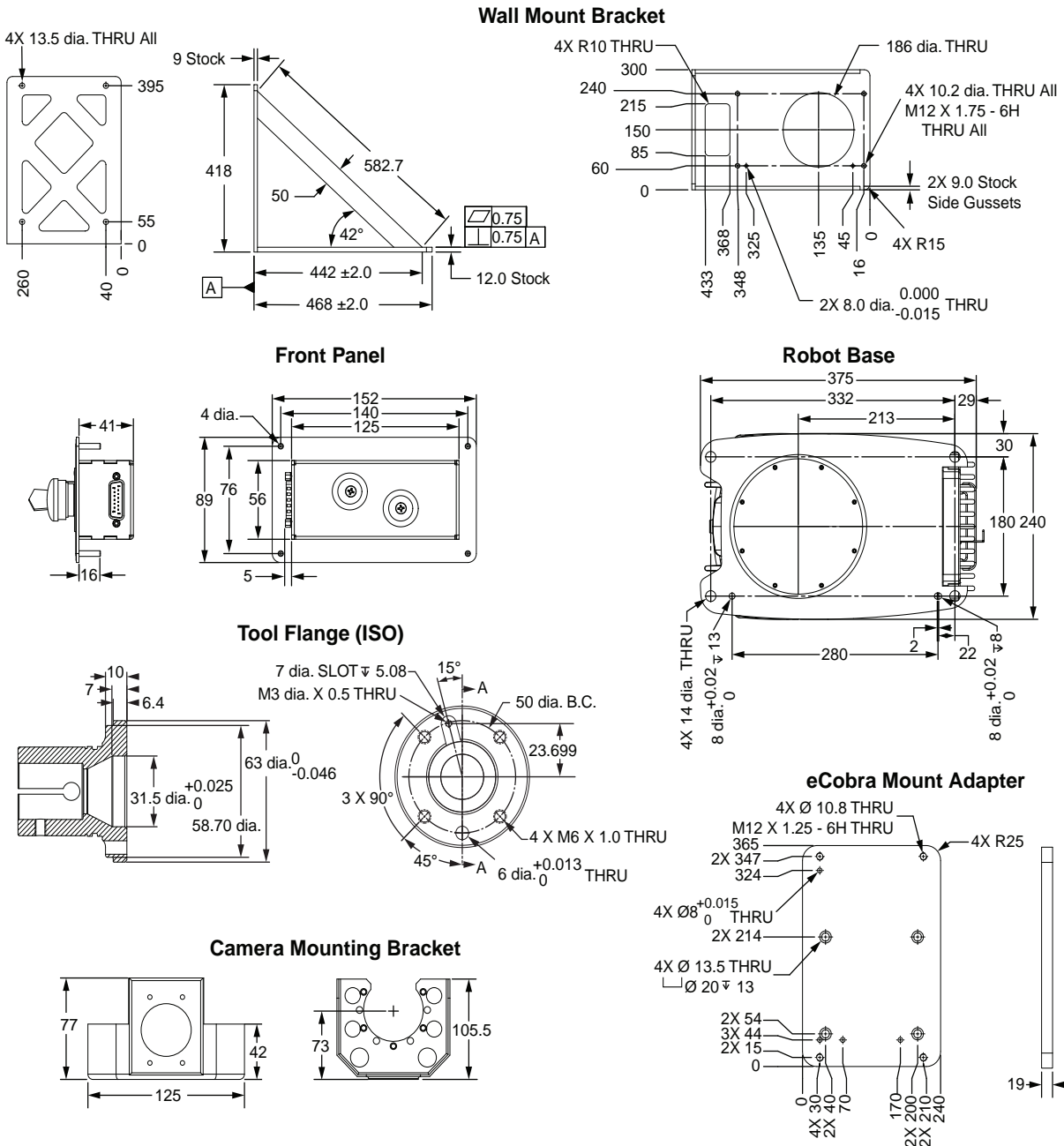

Camera Bracket

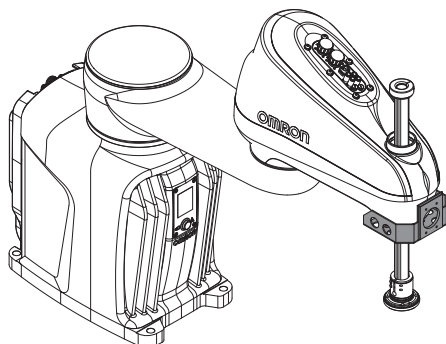

Cable Seal and Bellows

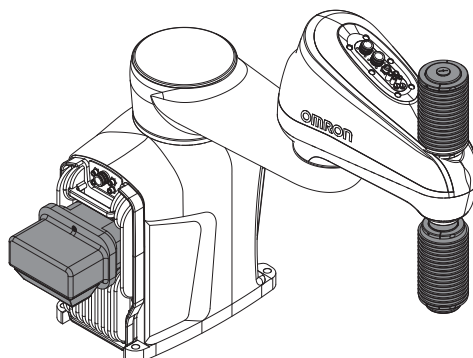

Related Manuals

Catalog Number	Manual Title
I590	Robot Safety Guide
I601	T20 Pendant User's Manual
I660	i4H Robots User's Manual
I661	i4H Robots with EtherCAT User's Manual
I632	IPC Application Controller User's Manual
I633	Automated Control Environment (ACE) Version 4 User's Manual
I671	V+ User's Manual
I672	V+ Keyword Reference Manual
O037	NJ-series Robot Integrated CPU Unit User's Manual
O049	Machine Automation Controller NJ-series Robot Integrated System Startup Guide
W504	Sysmac Studio Version 1 Operation Manual
W595	Sysmac Studio Robot Integrated System Building Function with Robot Integrated CPU Unit Operation Manual
W618	Sysmac Studio 3D Simulation Function Operation Manual
W621	Sysmac Studio Robot Integrated System Building Function with IPC Application Controller Operation Manual

Terms and Conditions Agreement

Read and understand this catalog.

Please read and understand this catalog before purchasing the products. Please consult your OMRON representative if you have any questions or comments.

Warranties.

- (a) Exclusive Warranty. Omron's exclusive warranty is that the Products will be free from defects in materials and workmanship for a period of twelve months from the date of sale by Omron (or such other period expressed in writing by Omron). Omron disclaims all other warranties, express or implied.
- (b) Limitations. OMRON MAKES NO WARRANTY OR REPRESENTATION, EXPRESS OR IMPLIED, ABOUT NON-INFRINGEMENT, MERCHANTABILITY OR FITNESS FOR A PARTICULAR PURPOSE OF THE PRODUCTS. BUYER ACKNOWLEDGES THAT IT ALONE HAS DETERMINED THAT THE PRODUCTS WILL SUITABLY MEET THE REQUIREMENTS OF THEIR INTENDED USE.

Omron further disclaims all warranties and responsibility of any type for claims or expenses based on infringement by the Products or otherwise of any intellectual property right. (c) Buyer Remedy. Omron's sole obligation hereunder shall be, at Omron's election, to (i) replace (in the form originally shipped with Buyer responsible for labor charges for removal or replacement thereof) the non-complying Product, (ii) repair the non-complying Product, or (iii) repay or credit Buyer an amount equal to the purchase price of the non-complying Product; provided that in no event shall Omron be responsible for warranty, repair, indemnity or any other claims or expenses regarding the Products unless Omron's analysis confirms that the Products were properly handled, stored, installed and maintained and not subject to contamination, abuse, misuse or inappropriate modification. Return of any Products by Buyer must be approved in writing by Omron before shipment. Omron Companies shall not be liable for the suitability or unsuitability or the results from the use of Products in combination with any electrical or electronic components, circuits, system assemblies or any other materials or substances or environments. Any advice, recommendations or information given orally or in writing, are not to be construed as an amendment or addition to the above warranty.

See <http://www.omron.com/global/> or contact your Omron representative for published information.

Limitation on Liability; Etc.

OMRON COMPANIES SHALL NOT BE LIABLE FOR SPECIAL, INDIRECT, INCIDENTAL, OR CONSEQUENTIAL DAMAGES, LOSS OF PROFITS OR PRODUCTION OR COMMERCIAL LOSS IN ANY WAY CONNECTED WITH THE PRODUCTS, WHETHER SUCH CLAIM IS BASED IN CONTRACT, WARRANTY, NEGLIGENCE OR STRICT LIABILITY.

Further, in no event shall liability of Omron Companies exceed the individual price of the Product on which liability is asserted.

Suitability of Use.

Omron Companies shall not be responsible for conformity with any standards, codes or regulations which apply to the combination of the Product in the Buyer's application or use of the Product. At Buyer's request, Omron will provide applicable third party certification documents identifying ratings and limitations of use which apply to the Product. This information by itself is not sufficient for a complete determination of the suitability of the Product in combination with the end product, machine, system, or other application or use. Buyer shall be solely responsible for determining appropriateness of the particular Product with respect to Buyer's application, product or system. Buyer shall take application responsibility in all cases.

NEVER USE THE PRODUCT FOR AN APPLICATION INVOLVING SERIOUS RISK TO LIFE OR PROPERTY OR IN LARGE QUANTITIES WITHOUT ENSURING THAT THE SYSTEM AS A WHOLE HAS BEEN DESIGNED TO ADDRESS THE RISKS, AND THAT THE OMRON PRODUCT(S) IS PROPERLY RATED AND INSTALLED FOR THE INTENDED USE WITHIN THE OVERALL EQUIPMENT OR SYSTEM.

Programmable Products.

Omron Companies shall not be responsible for the user's programming of a programmable Product, or any consequence thereof.

Performance Data.

Data presented in Omron Company websites, catalogs and other materials is provided as a guide for the user in determining suitability and does not constitute a warranty. It may represent the result of Omron's test conditions, and the user must correlate it to actual application requirements. Actual performance is subject to the Omron's Warranty and Limitations of Liability.

Change in Specifications.

Product specifications and accessories may be changed at any time based on improvements and other reasons. It is our practice to change part numbers when published ratings or features are changed, or when significant construction changes are made. However, some specifications of the Product may be changed without any notice. When in doubt, special part numbers may be assigned to fix or establish key specifications for your application. Please consult with your Omron's representative at any time to confirm actual specifications of purchased Product.

Errors and Omissions.

Information presented by Omron Companies has been checked and is believed to be accurate; however, no responsibility is assumed for clerical, typographical or proofreading errors or omissions.

Note: Do not use this document to operate the Unit.

OMRON Corporation Industrial Automation Company
Kyoto, JAPAN

Contact: www.ia.omron.com

Regional Headquarters

OMRON EUROPE B.V.

Wegalaan 67-69, 2132 JD Hoofddorp
The Netherlands

Tel: (31)2356-81-300/Fax: (31)2356-81-388

OMRON ELECTRONICS LLC

2895 Greenspoint Parkway, Suite 200
Hoffman Estates, IL 60169 U.S.A.

Tel: (1) 847-843-7900/Fax: (1) 847-843-7787

OMRON ASIA PACIFIC PTE. LTD.

438B Alexandra Road, #08-01/02 Alexandra
Technopark, Singapore 119968

Tel: (65) 6835-3011/Fax: (65) 6835-2711

OMRON (CHINA) CO., LTD.

Room 2211, Bank of China Tower,
200 Yin Cheng Zhong Road,
PuDong New Area, Shanghai, 200120, China

Tel: (86) 21-5037-2222/Fax: (86) 21-5037-2200

Authorized Distributor:

© OMRON Corporation 2022 All Rights Reserved.
In the interest of product improvement,
specifications are subject to change without notice.

CSM_2_1

Cat. No. I873-E-02

0622 (0222)

23490-100 B